

Acct ID: 529961 MTL: 082W17D001502 Date: 12/3/24 Appr: MNL Prop Class: 401 RMV Prop Class: 401
 Situs: 5560 JENNICHES LN SE SALEM OR 97317 MaSaNh: 07 06 000 Unit: 22752 Year: 2024
2025

Last Date Appraised: 01/04/2024 Appraiser: MATT LORD Retag: Y (N) Tag info: 2025 - Tags/Permit (Completion)
 Owner: DEBRA L JENSEN 2017 LT & Roll Type: R
 Cycle: (Tag) Sales Verification Other: _____ Inspection level: 1 (2) 3 4 LCB TTO INSP AV: 633250
 RMV Land: 244050 RMV Imp: 1147070 RMV Total: 1391120 MAV: 614180 MSAV: 0 SAV: 0
 Comment: 24-25: L2 01.04.24 GRH 23-006719 65%

Notations 25-26 100% complete; Full TAB; Exception
 No notation data available.

OSDs

Count	Code	Description	RMV	Code Area	Exception
1	MKTG	OSD - GOOD ✓	55000	05590	0

Land ✓

Site: 1 Code Area: 05590 Size: 2.04 Acres Use Code: 004 Zone: NREST SAV Use: Exception: 0
 Class: 4HD ✓ Value Source: Rural at MKT Description: FOUR HILL DRY RMV: 189050 Exception: Y N
 Adjustment(s): Fire Patrol: Description:
 Comments: 24-25: Updated land classes
 18-19: DISQ FARM USE / 17-18: SV PER #102 CHG OSD// 16-17: PER #90 ADJ SOIL CLASSES//
 14-15: 1.0 ACRE DISQ FARM USE FOR NON SA HOMESITE// 02-03: REAPPRAISAL //04-05 LAND ADJUSTMENT PROJECT FOR
 RECALCULATION
 CHG SOIL CLASS FROM 2HILL DRY TO 4HILL DRY

Improvements - Residence / Manufactured Structures

Bldg: 1 Code Area: 05590 Stat Class: 152 + Year Blt: 2013 Eff Year Blt: 2013 Sq.Ft: 5021 % Complete: 100
 Desc: Multi Story above grade Dimensions: RMV: 1107860
 Func Obsc: 100 Econ %: 100 Other %: 100 Exception: 0 Adjust: Adjust RMV: 0

Floors

Type	Class	Display Group	Floor Size	Beds	Baths	Yr Blt	Eff Yr Blt	Inventory	Exception
First Floor	5 +	Finished	3864	4	FB-4	2013	2013	BATH - 4, KIT, BATH+, ROOF, HVAC+, FP - 1	Y N
Second Floor	5 +	Finished	1157	1	FB-1	2013	2013	BATH - 1, HVAC+	Y N
Garage Attached	5	Finished	1040	0	0	2013	2013	ROOF	Y N

Accessories

Description	Class	Size SqFt	Eff Yr Blt	RMV	Quantity	Exception
OUTDOOR AMENITIES FP / KITCHEN <u>UPDATE</u>	5	80	2014	5000	1	Y N
YARD IMPROVEMENTS GOOD	5	1	2013	44888	1	Y N

Improvements - Accessory Buildings

Bldg: 2 Code Area: 05590 Stat Class: 351 Year Blt: 2023 Eff Year Blt: 2023 Sq.Ft: 2400 % Complete: 65
 Desc: General Purpose Building (GB) Dimensions: 60x40 RMV: 36050 100
 Func Obsc: 100 Econ %: 100 Other %: 100 Exception: 17530 Adjust: Adjust RMV: 0

Floors

Type	Class	Display Group	Floor Size	Beds	Baths	Yr Blt	Eff Yr Blt	Inventory	Exception
General Purpose Bldg	5	Finished	2400	0	0	2023	2023	<u>AVG FAIR</u>	Y N

Accessories

Description	Class	Size SqFt	Eff Yr Blt	RMV	Quantity
No accessory data available					

Bldg: 3 Code Area: 05590 Stat Class: 355 Year Blt: 2023 Eff Year Blt: 2023 Sq.Ft: 720 % Complete: 65
 Desc: Lean-to Heavy (LTH) Dimensions: 60x12 RMV: 3160 100
 Func Obsc: 100 Econ %: 100 Other %: 100 Exception: 1540 Adjust: Adjust RMV: 0

Floors

Type	Class	Display Group	Floor Size	Beds	Baths	Yr Blt	Eff Yr Blt	Inventory	Exception
Lean-to Heavy Duty	4	Finished	720	0	0	2023	2023		Y N

Accessories

Description	Class	Size SqFt	Eff Yr Blt	RMV	Quantity
No accessory data available					



12/3/24



SKETCH/AREA TABLE ADDENDUM

SUBJECT INFO

File No.: 529961 Parcel No.: 082W17D 01502
 Property Address: 5560 JENNICHES LN SE
 City: SALEM County: MARION State: OR ZipCode: 97317
 Owner:
 Client: Client Address:
 Appraiser Name: Inspection Date:

SKETCH

529961
082W17D 01502
SCALE = 1:35

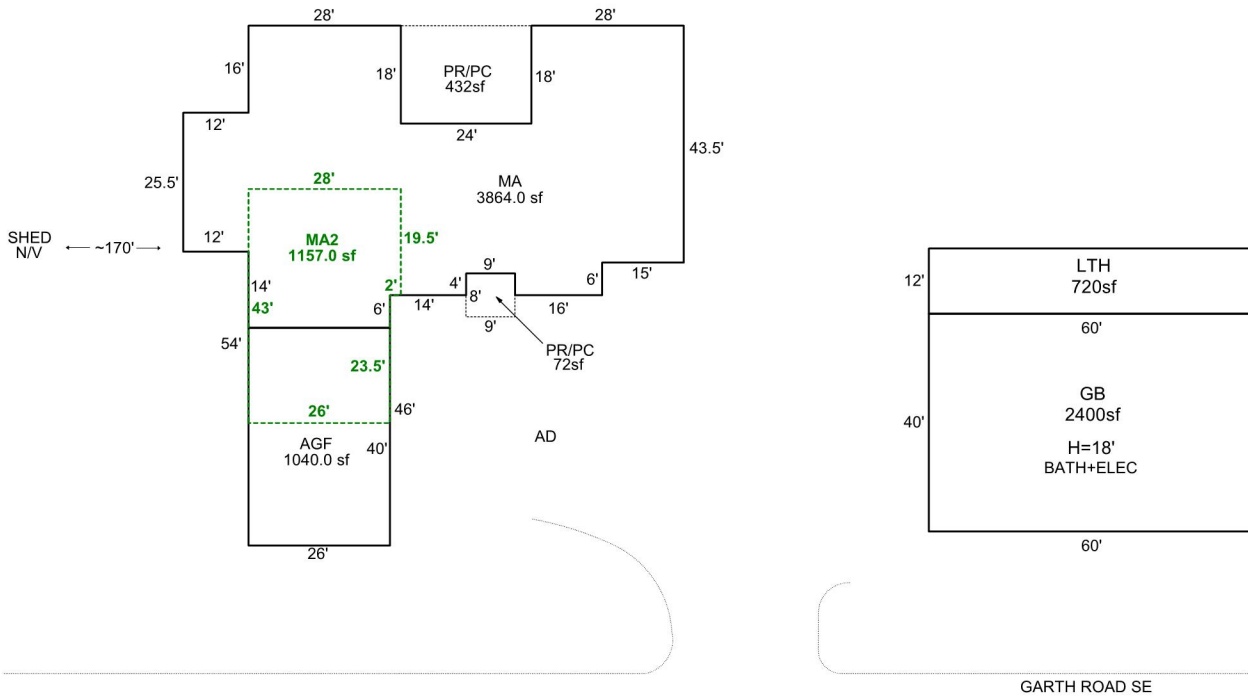

Sketch by Apex Sketch

AREA CALCULATIONS SUMMARY

Code	Description	Factor	Net Size	Perimeter	Net Totals
GBA1	GB	1.0	2400.0	200.0	
	LTH	1.0	720.0	144.0	3120.0
GLA1	MA	1.0	3864.0	339.0	3864.0
GLA2	MA2	1.0	1157.0	142.0	1157.0
P/P	PR/PC	1.0	72.0	34.0	
	PR/PC	1.0	432.0	84.0	504.0

COMMENT TABLE 1

DRAWN BY SRAGSDALE 12/10/13
 UPDATED BY JRONDEMA 5/20/15
 UPDATED BY CJURAN 10/31/2023 23-006719 GB
 UPDATED BY CJURAN 01/22/2024

COMMENT TABLE 2

GRH 01/04/2023

COMMENT TABLE 3

TAGS L2

Net LIVABLE	cnt	2	(rounded)		5,021
Net BUILDING	cnt	2	(rounded)		3,120

SKETCH/AREA TABLE ADDENDUM

SUBJECT INFO

File No.: 529961 Parcel No.: 082W17D 01502
 Property Address: 5560 JENNICHES LN SE
 City: SALEM County: MARION State: OR ZipCode: 97317
 Owner:
 Client: Client Address:
 Appraiser Name: Inspection Date:

SKETCH

529961
082W17D 01502
SCALE = 1:35

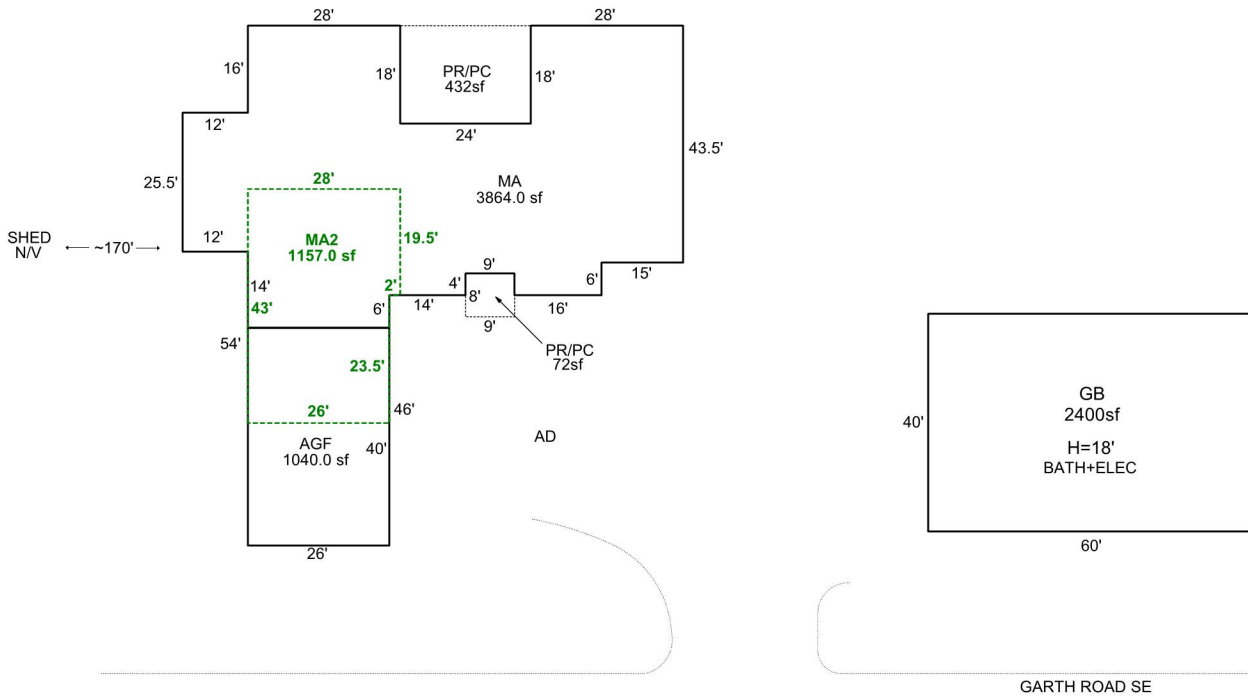

Sketch by Apex Sketch

AREA CALCULATIONS SUMMARY

Code	Description	Factor	Net Size	Perimeter	Net Totals
GBA1	GB	1.0	2400.0	200.0	2400.0
GLA1	MA	1.0	3864.0	339.0	3864.0
GLA2	MA2	1.0	1157.0	142.0	1157.0
P/P	PR/PC	1.0	72.0	34.0	
	PR/PC	1.0	432.0	84.0	504.0

COMMENT TABLE 1

DRAWN BY SRAGSDALE 12/10/13
 UPDATED BY JRONDEMA 5/20/15
 UPDATED BY CJURAN 10/31/2023 23-006719 GB

COMMENT TABLE 2

COMMENT TABLE 3

Net LIVABLE	cnt	2	(rounded)		5,021
Net BUILDING	cnt	1	(rounded)		2,400



MA

R29961
07/27/2017

























