

Acct ID: 354791 MTL: 082W11B002901 Date: 10-29-24 Appr: Genice Prop Class: 401 RMV Prop Class: 401
 Situs: 4270 75TH AVE SE SALEM OR 97317 MaSaNh: 01 06 004 Unit: 28273 Year: 2024
 Last Date Appraised: 01/05/2024 Appraiser: CLINT LUKE Retag: Y N Tag info: 2025 - Tags/Permit (Completion)
 Owner: RASMUSSEN, BENJAMIN D Roll Type: R
 Cycle: Tag Sales Verification Other: _____ Inspection level: 1 2 3 4 LCB TTO INSP AV: 494220
 RMV Land: 275190 RMV Imp: 922990 RMV Total: 1198180 MAV: 480030 MSAV: 0 SAV: 0
 Comment: 24-25: L2 01.05.24 GRH
 23-24: L2 01.27.23 MLH

INPUT
11-5-24
Genice

Notations No notation data available.

23-003286 GB 100%
 CHANGE GB TO VB

OSDs

Count	Code	Description	RMV	Code Area	Exception
1	MKTA	OSD - AVERAGE	45000	92410	0

Land

Site: 1	Code Area: 92410	Size: 0.32 Acres	Use Code: 004	Zone: NREST	SAV Use:	Exception: 0
Class: 2BDS	Value Source: Rural at MKT	Description: TWO BENCH DRY SOUTH SPECIAL	RMV: 39880	Exception: Y	N	
Adjustment(s): GSOIL		Fire Patrol:	Description:			
Comments: 19-20: PER #94 ADD OSD / 18-19: DISQ FARM USE						

NC

Improvements - Residence / Manufactured Structures

Bldg: 1	Code Area: 92410	Stat Class: 152 +	Year Blt: 2018	Eff Year Blt: 2018	Sq.Ft: 3537	% Complete: 100
Desc: Multi Story above grade					Dimensions:	RMV: 848210
Func Obsc: 100	Econ %: 100	Other %: 100	Exception: 0	Adjust:	Adjust RMV: 0	

1/0

Type	Class	Display Group	Floor Size	Beds	Baths	Yr Blt	Eff Yr Blt	Inventory	Exception
First Floor	5 +	Finished	2035	2	FB-1/ HB-1	2018	2018	BATH - 1, BTH - 1, KIT-, ROOF HVAC+, FP - 1	Y N
Second Floor	5 +	Finished	1502	3	FB-3	2018	2018	BATH - 3, HVAC+	Y N
Garage Attached	5 +	Finished	828	0	0	2018	2018	ROOF	Y N

AVC
AVB

Accessories

Description	Class	Size SqFt	Eff Yr Blt	RMV	Quantity
SWIMMING POOL	5	800	2022	25000	0

Bldg: 2	Code Area: 92410	Stat Class: 107	Year Blt: 2018	Eff Year Blt: 2018	Sq.Ft: 0	% Complete: 100
Desc: Yard Improvements					Dimensions:	RMV: 45190
Func Obsc: 100	Econ %: 100	Other %: 100	Exception: 0	Adjust:	Adjust RMV: 0	

Floors

Type	Class	Display Group	Floor Size	Beds	Baths	Yr Blt	Eff Yr Blt	Inventory
No floor data available								

NC

Accessories

Description	Class	Size SqFt	Eff Yr Blt	RMV	Quantity
YARD IMPROVEMENTS AVERAGE	5	0	2018	37044	1

Improvements - Accessory Buildings

Bldg: 3	Code Area: 92410	Stat Class: 354	Year Blt: 2018	Eff Year Blt: 2018	Sq.Ft: 110	% Complete: 100
Desc: Lean-to Light (LTL)					Dimensions: 11x10	RMV: 400
Func Obsc: 100	Econ %: 100	Other %: 100	Exception: 0	Adjust:	Adjust RMV: 0	

Floors

Type	Class	Display Group	Floor Size	Beds	Baths	Yr Blt	Eff Yr Blt	Inventory
Lean-to Light Duty	4	Finished	110	0	0	2018	2018	

NC

Accessories

Description	Class	Size SqFt	Eff Yr Blt	RMV	Quantity				
No accessory data available									
Bldg: 4	Code Area: 92410	Stat Class: 351	Year Blt: 2023	Eff Year Blt: 2023	Sq.Ft: 2400	% Complete: 50			
Desc: General Purpose Building (GB)					Dimensions: 60x40	RMV: 27730			
Func Obsc: 100	Econ %: 100	Other %: 100	Exception: 13480	Adjust: 52x60	Adjust RMV: 0				
Floors									
Type	Class	Display Group	Floor Size	Beds	Baths	Yr Blt	Eff Yr Blt	Inventory	Exception: Y N
General Purpose Bldg	5	Finished	2400	0	0	2023	2023	AVG	
Accessories									
Description	Class	Size SqFt	Eff Yr Blt	RMV	Quantity				
No accessory data available									
Bldg: 5	Code Area: 92410	Stat Class: 354	Year Blt: 2023	Eff Year Blt: 2023	Sq.Ft: 720	% Complete: 50			
Desc: Lean-to Light (LTL)					Dimensions: 60x12	RMV: 1460			
Func Obsc: 100	Econ %: 100	Other %: 100	Exception: 710	Adjust:	Adjust RMV: 0				
Floors									
Type	Class	Display Group	Floor Size	Beds	Baths	Yr Blt	Eff Yr Blt	Inventory	Exception: Y N
Lean-to Light Duty	4	Finished	720	0	0	2023	2023		
Accessories									
Description	Class	Size SqFt	Eff Yr Blt	RMV	Quantity				
No accessory data available									



10/29/24



10/29/24

SKETCH/AREA TABLE ADDENDUM

SUBJECT INFO			
File No.: 354791	Parcel No.: 082W11B 02901		
Property Address: 4270 75TH AVE SE			
City: SALEM	County: MARION	State: OR	ZipCode: 97317
Owner:			
Client:		Client Address:	
Appraiser Name:		Inspection Date:	

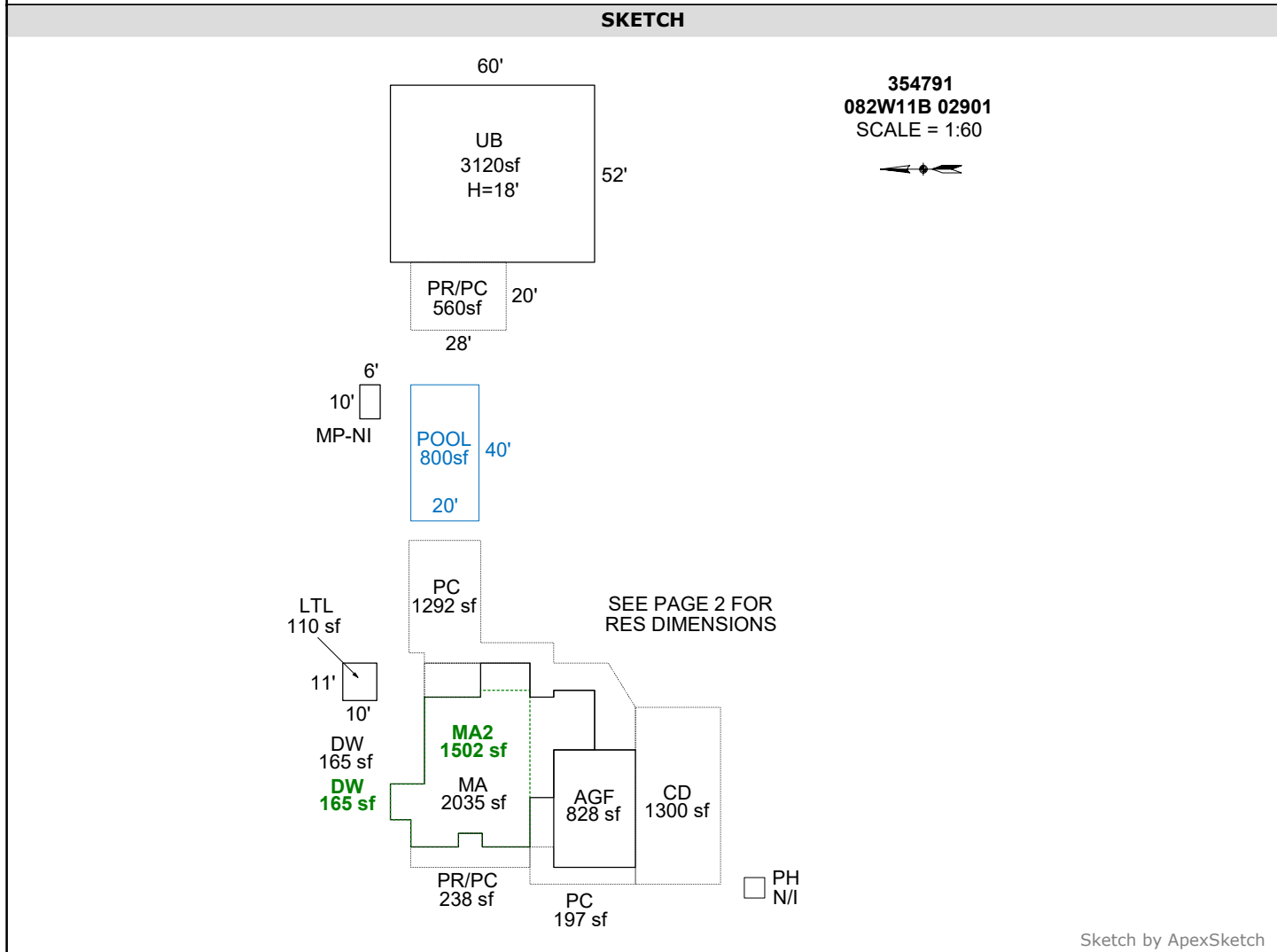

AREA CALCULATIONS SUMMARY						COMMENT TABLE 1	
Code	Description	Factor	Net Size	Perimeter	Net Totals		
GBA1	LTL	1.0	110.0	42.0		DRAWN BY JRONDEMA 3/5/18 UPDATED BY JRONDEMA 11/13/18 UPDATED BY CJURAN 03/09/2022 555-22-000812 UPDATED BY CJURAN 02/15/2023 UPDATED BY CJURAN 09/20/2023 23-003286 GB UPDATED BY CJURAN 02/08/2024 UPDATED BY CLOBERG 11/08/24	
	UB	1.0	3120.0	224.0	3230.0		
GLA1	MA	1.0	2034.5	240.0	2034.5		
GLA2	MA2	1.0	1502.0	182.0	1502.0		
GAR	AGF	1.0	828.0	117.0	828.0		
OTH	POOL	1.0	800.0	120.0	800.0		
P/P	PC	1.0	197.0	84.0			
	PR/PC	1.0	238.0	90.0			
	CD	1.0	1300.0	154.0			
	PC	1.0	1291.5	254.3			
	DW	1.0	165.0	53.0			
	DW	1.0	165.0	53.0			
	PR/PC	1.0	560.0	96.0	3916.5		
	Net LIVABLE	cnt	2 (rounded)		3,537		
	Net BUILDING	cnt	2 (rounded)		3,230		

COMMENT TABLE 2	COMMENT TABLE 3
10.30.18 SR #94 TAGS MLH 01/27/2023 GRH 01/05/2024 CLUKE 10/29/24	TAGS L2 TAGS L2 TAGS L2

SKETCH/AREA TABLE ADDENDUM

SUBJECT INFO

File No.: 354791 Parcel No.: 082W11B 02901
 Property Address: 4270 75TH AVE SE
 City: SALEM County: MARION State: OR ZipCode: 97317
 Owner:
 Client: Client Address:
 Appraiser Name: Inspection Date:

SKETCH

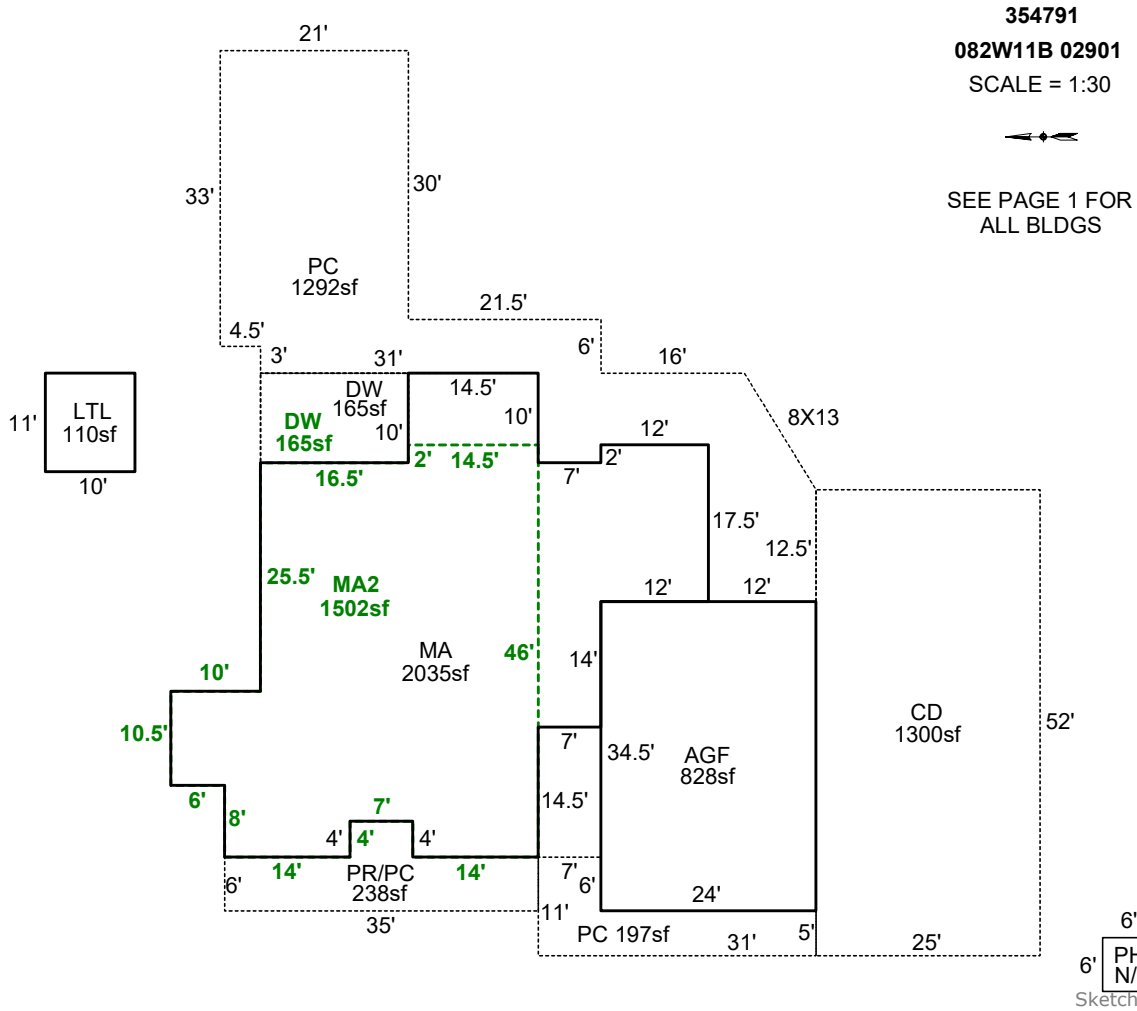

AREA CALCULATIONS SUMMARY

Code	Description	Factor	Net Size	Perimeter	Net Totals
GBA1	LTL	1.0	110.0	42.0	110.0
GLA1	MA	1.0	2034.5	240.0	2034.5
GLA2	MA2	1.0	1502.0	182.0	1502.0
GAR	AGF	1.0	828.0	117.0	828.0
P/P	PC	1.0	1291.5	254.3	
	DW	1.0	165.0	53.0	
	PR/PC	1.0	238.0	90.0	
	PC	1.0	197.0	84.0	
	CD	1.0	1300.0	154.0	
	DW	1.0	165.0	53.0	3356.5
	Net LIVABLE	cnt	2 (rounded)		3,537
	Net BUILDING	cnt	1 (rounded)		110

COMMENT TABLE 1

DRAWN BY JRONDEMA 3/5/18
 UPDATED BY JRONDEMA 11/13/18
 UPDATED BY CJURAN 03/09/2022 555-22-000812
 UPDATED BY CJURAN 02/15/2023
 UPDATED BY CJURAN 09/20/2023 23-003286 GB
 UPDATED BY CJURAN 02/08/2024
 UPDATED BY CLOBERG 11/08/24

COMMENT TABLE 2

10.30.18 SR #94 TAGS
 MLH 01/27/2023
 GRH 01/05/2024
 CLUKE 10/29/24

COMMENT TABLE 3

TAGS L2
 TAGS L2
 TAGS L2