

Acct ID: 355166 MTL: 081W350000503 Date: 12-12-23 Appr: MDL Prop Class: 551 RMV Prop Class: 551
 Situs: 7987 BOEDIGHEIMER RD SE SUBLIMITY OR 97385 MaSaNh: 07 06 000 Unit: 37658 Year: 2023
2024

Last Date Appraised: 01/27/2022 Appraiser: MATT LORD Retag: Y N Tag info: 2024 - NEW RESIDENCE (Completion)

Owner: ELWOOD, SANDI S Chris 6/12/24 Roll Type: R

Cycle: 1 Sales Verification Other: _____ Inspection level: 1 2 3 4 LCB TTO INSP AV: 613491

RMV Land: 198130 RMV Imp: 874710 RMV Total: 1072840 MAV: 227670 MSAV: 9111 SAV: 85584

Comment: 22-23 L2 1/27/22 ML

*100% complete GONE THE 30X60 MS SHOULD HAVE BEEN GONE LAST YEAR BRING BACK THE 30X72 UB THAT WAS GONE BY MISTAKE OF SFD; * FARM USE (Horse bonding) 21-009872*

Notations 24-25:

RP/MS	Code	Description
RP	411	SEE ACCOUNT NOTES - 411
RP	ZONED	FARM EFU ZONED

OSDs

Count	Code	Description	RMV	Code Area	Exception
1	SAF	SA OSD - FAIR	35000	29588	0

Land

Site: 1 Code Area: 29588 Size: 1.00 Acres Use Code: 005 Zone: REST SAV Use: 011 Exception: 0
 Class: 2BD Value Source: Farm Homesite Description: TWO BENCH DRY RMV: 78800 Exception: Y N
 Adjustment(s): GSOIL Fire Patrol: SA004 Description: FIRE PATROL
 Comments: Liability year - 2009 / 21-22: UPDATE PART TOTALS / 21-22: PER #103 CHG LAND SCH FOR WOODLOT / 19-20: MANUALLY ADJUST MSAV, XFER INCORRECTLY IN 18-19 FROM R29099

Site: 3 Code Area: 29588 Size: 1.07 Acres Use Code: 005 Zone: REST SAV Use: 011 Exception: 0
 Class: 2BD Value Source: Farm Use - EFU Description: TWO BENCH DRY RMV: 84330 Exception: Y N
 Adjustment(s): GSOIL Fire Patrol: SA004 Description: FIRE PATROL
 Comments:

Improvements - Residence / Manufactured Structures

Bldg: 1 Code Area: 29588 Stat Class: 144 Year Blt: 1947 Eff Year Blt: 1947 Sq.Ft: 2830 % Complete: 100
 Desc: Multi Story above grade with basement Dimensions: RMV: 439780
 Func Obsc: 100 Econ %: 100 Other %: 100 Exception: 0 Adjust: Adjust RMV: 0

Floors

Type	Class	Display Group	Floor Size	Beds	Baths	Yr Blt	Eff Yr Blt	Inventory	Exception
First Floor	4	Finished	2120	2	FB-2	1947	1947	BATH - 2, KIT+, ROOF, HVAC+, FB	Y N
Attic	4	Finished	710	2	0	1947	1947	HVAC	Y N
Basement	4	Unfinished	1640	0	FB-1	1947	1947	BATH - 1	Y N
Carport Attached	4	Unfinished	416	0	0	1947	1947	ROOF	Y N

Accessories

Description	Class	Size SqFt	Eff Yr Blt	RMV	Quantity	Exception
ASPHALT DRIVEWAY	4	3870	1947	7663	1	Y N
DECK	4	440	1947	6389	1	Y N
PATIO	4	40	1947	145	1	Y N
PATIO	4	420	1947	1525	1	Y N
PATIO	4	430	1947	1561	1	Y N
ROOF EXTENSION OR PATIO COVER	4	40	1947	766	1	Y N

Bldg: 7 Code Area: 29588 Stat Class: 151 Year Blt: 2022 Eff Year Blt: 2022 Sq.Ft: 3306 % Complete: 50
 Desc: One Story Only Dimensions: RMV: 376710
 Func Obsc: 100 Econ %: 100 Other %: 100 Exception: 376710 Adjust: Adjust RMV: 0

Floors

Type	Class	Display Group	Floor Size	Beds	Baths	Yr Blt	Eff Yr Blt	Inventory	Exception
First Floor	<u>5</u>	Finished	3306	3	FB-2	2022	2022	BATH - 2, KIT, BATH+, ROOF, HVAC+	Y N
Garage Attached	<u>5</u>	Finished	1444	0	0	2022	2022	ROOF	Y N

Accessories

Description	Class	Size SqFt	Eff Yr Blt	RMV	Quantity	Exception
YARD IMPROVEMENTS AVERAGE	4	0	2022	15593	1	Y N

Improvements - Accessory Buildings

Bldg: 4 Code Area: 29588 Stat Class: 353 Year Blt: 1995 Eff Year Blt: 1995 Sq.Ft: 1800 % Complete: 100

Desc: Machine Shed (MS) Dimensions: 60x30 RMV: 14620

Func Obsc: 100 Econ %: 100 Other %: 100 Exception: 0 Adjust: Adjust RMV: 0

Floors

Type	Class	Display Group	Floor Size	Beds	Baths	Yr Blt	Eff Yr Blt	Inventory
Machine Shed	5	Finished	1800	0	0	1995	1995	FAIR

SHOULD HAVE BEEN REMOVED LAST YEAR WRONG BLDG YEAR LAST SEE PHOTO OF LAST YEAR'S SUB SHEET BELOW

Accessories

Description Class Size SqFt Eff Yr Blt RMV Quantity

No accessory data available

Bldg: 5 Code Area: 29588 Stat Class: 351 Year Blt: 2021 Eff Year Blt: 2021 Sq.Ft: 864 % Complete: 100

Desc: General Purpose Building (GB) Dimensions: 72x12 RMV: 32400

Func Obsc: 100 Econ %: 100 Other %: 100 Exception: 0 Adjust: Adjust RMV: 0

Floors

Type	Class	Display Group	Floor Size	Beds	Baths	Yr Blt	Eff Yr Blt	Inventory
General Purpose Bldg	6	Finished	864	0	0	2021	2021	AVG

Accessories

Description Class Size SqFt Eff Yr Blt RMV Quantity

No accessory data available

Bldg: 6 Code Area: 29588 Stat Class: 356 Year Blt: 2021 Eff Year Blt: 2021 Sq.Ft: 864 % Complete: 100

Desc: Lean-to Excellent (LTE) Dimensions: 72x12 RMV: 11200

Func Obsc: 100 Econ %: 100 Other %: 100 Exception: 0 Adjust: Adjust RMV: 0

Floors

Type	Class	Display Group	Floor Size	Beds	Baths	Yr Blt	Eff Yr Blt	Inventory
Lean-to Excellent	4	Finished	864	0	0	2021	2021	

Accessories

Description Class Size SqFt Eff Yr Blt RMV Quantity

No accessory data available



12/12/23

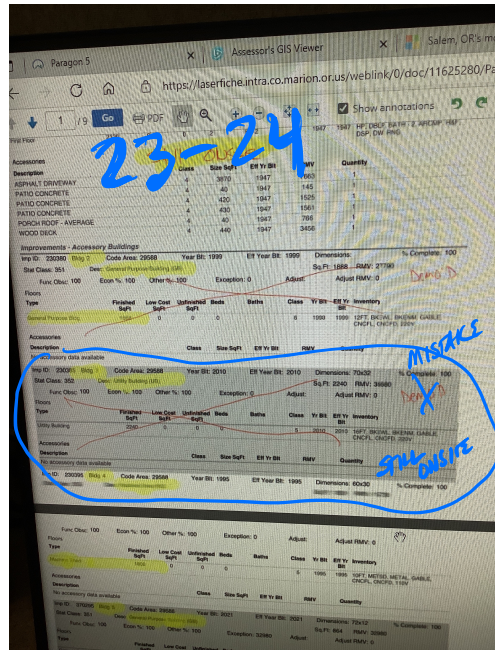

SKETCH/AREA TABLE ADDENDUM

SUBJECT INFO

File No.: 355166 Parcel No.: 081W35 00503
 Property Address: 7987 BOEDIGHEIMER RD SE
 City: SUBLIMITY County: MARION State: OR ZipCode: 97385
 Owner:
 Client: Client Address:
 Appraiser Name: Inspection Date:

SKETCH

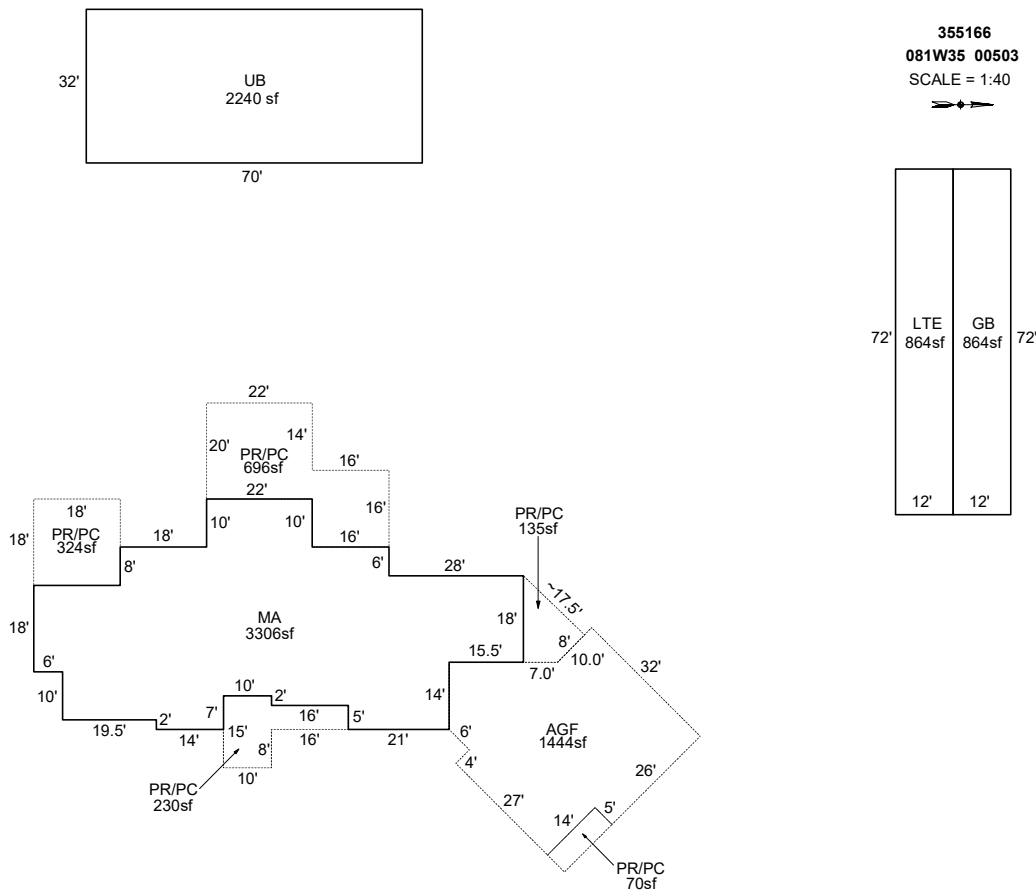

Sketch by Apex Sketch

AREA CALCULATIONS SUMMARY						COMMENT TABLE 1			
Code	Description	Factor	Net Size	Perimeter	Net Totals				
GBA1	UB	1.0	2240.0	204.0		DRAWN BY JRONDEMA 2/13/18 UPDATED BY JRONDEMA 6/4/18 UPDATED BY CJURAN 01/06/2022 UPDATED BY CJURAN 01/18/2022 555-21-009872 UPDATED BY CJURAN 03/21/2023 UPDATED BY CJURAN 12/19/2023			
	GB	1.0	864.0	168.0					
	LTE	1.0	864.0	168.0	3968.0				
GLA1	MA	1.0	3306.0	314.0	3306.0				
P/P	AGF	1.0	1444.2	160.7					
	PR/PC	1.0	70.0	38.0					
	PR/PC	1.0	324.0	72.0					
	PR/PC	1.0	230.0	82.0					
	PR/PC	1.0	696.0	136.0					
	PR/PC	1.0	135.0	50.8	2899.2				
						COMMENT TABLE 2	COMMENT TABLE 3		
						#10 CL 07/20/2021 MDL 01/03/2023 CL 12/12/2023	CYCLE L2 TAGS L2 TAGS L3		
		Net LIVABLE	cnt	1 (rounded)	3,306				
		Net BUILDING	cnt	3 (rounded)	3,968				

SKETCH/AREA TABLE ADDENDUM

SUBJECT INFO

File No.: 355166 Parcel No.: 081W35 00503
 Property Address: 7987 BOEDIGHEIMER RD SE
 City: SUBLIMITY County: MARION State: OR ZipCode: 97385
 Owner:
 Client: Client Address:
 Appraiser Name: Inspection Date:

SKETCH

355166
081W35 00503
 SCALE = 1:20



SEE PAGE 1 FOR
 FULL LAYOUT

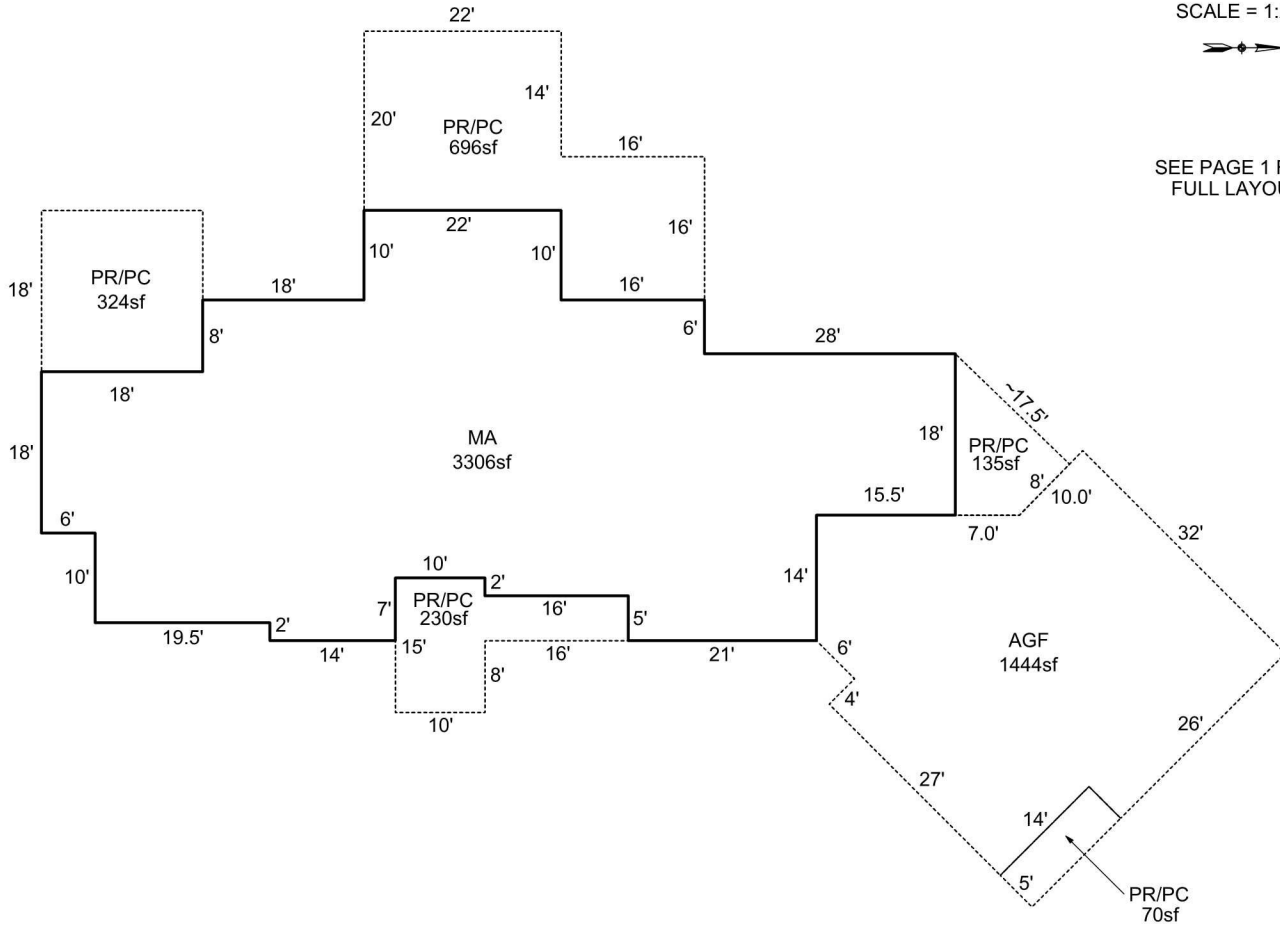

Sketch by Apex Sketch

AREA CALCULATIONS SUMMARY

Code	Description	Factor	Net Size	Perimeter	Net Totals
GLA1	MA	1.0	3306.0	314.0	3306.0
P/P	PR/PC	1.0	324.0	72.0	
	PR/PC	1.0	696.0	136.0	
	PR/PC	1.0	135.0	50.8	
	PR/PC	1.0	70.0	38.0	
	PR/PC	1.0	230.0	82.0	
	AGF	1.0	1444.2	160.7	2899.2

COMMENT TABLE 1

DRAWN BY JRONDEMA 2/13/18
 UPDATED BY JRONDEMA 6/4/18
 UPDATED BY CJURAN 01/06/2022
 UPDATED BY CJURAN 01/18/2022 555-21-009872

COMMENT TABLE 2

#10 CL 07/20/2021

COMMENT TABLE 3

CYCLE L2

Net LIVABLE cnt 1 (rounded) 3,306