

Chris 7/16/24

Acct ID: 352009 MTL: 061E29A002100 Date: **9-14-23** Appr: **ENCE** Prop Class: 401 RMV Prop Class: 401
 Situs: 16992 SILVER OAKS LN NE SILVERTON OR 97137 MaSaNh: 01 06 008 Unit: 57987 Year: 2023
 Last Date Appraised: 09/25/2019 Appraiser: CLINT LUKE Retag: **Y** Tag info: 2024 - NEW CONSTRUCTION (Addition)
 Owner: BEYER, CARL A Roll Type: R
 Cycle: **Tag** Sales Verification Other: _____ **WW** Inspection level: 1 2 3 4 LCB TTO **INSP** AV: 378750
 RMV Land: 267050 RMV Imp: 664050 RMV Total: 931100 MAV: 390110 MSAV: 0 SAV: 0
 Comment: **MA, ATP, ACP ADDN'S 100% Pm TAG**

Notations

No notation data available.

OSDs

Count	Code	Description	RMV	Code Area	Exception
1	MKTA	OSD - AVERAGE	45000	04500	0

Land

Site: 1 Code Area: 04500 Size: 2.15 Acres Use Code: 004 Zone: NREST SAV Use: Exception: 0
 Class: Value Source: Rural at MKT Description: **4BDSS** RMV: 222050 Exception: Y N
 Adjustment(s): Fire Patrol: Description:
 Comments: 19-20: PER #31 ADD OSD FOR NEW RES

Improvements - Residence / Manufactured Structures

Bldg: 1 Code Area: 04500 Stat Class: 152 Year Blt: 2018 Eff Year Blt: 2018 Sq.Ft: 3072 % Complete: 100
 Desc: Multi Story above grade Dimensions: RMV: 658930
 Func Obsc: 100 Econ %: 100 Other %: 100 Exception: 0 Adjust: Adjust RMV: 0

Floors

Type	Class	Display Group	Floor Size	Beds	Baths	Yr Blt	Eff Yr Blt	Inventory	Exception: Y N
First Floor	5	Finished	2685	4	FB-2/ HB-1	2018	2018	BATH - 2, BTH - 1, KIT, BATH+, ROOF	Y N
Attic	4	Finished	387	0	FB-1	2018	2018	BATH - 1	Y N
Garage Attache	5	Finished	741	0	0	2018	2018	ROOF	Y N

Accessories

Description	Class	Size SqFt	Eff Yr Blt	RMV	Quantity	Exception: Y N
CONCRETE DRIVEWAY	5	320	2019	1030	1	Y N
PATIO	5	185	2019	1007	1	Y N
PATIO	5	277	2019	1508	1	Y N
ROOF EXTENSION OR PATIO COVER	5	185	2019	5311	1	Y N
ROOF EXTENSION OR PATIO COVER	5	277	2019	7953	1	Y N

Improvements - Accessory Buildings

Bldg: 2 Code Area: 04500 Stat Class: 341 Year Blt: 2019 Eff Year Blt: 2019 Sq.Ft: 192 % Complete: 100
 Desc: Multi Purpose Shed (M) Dimensions: 16x12 RMV: 5120
 Func Obsc: 100 Econ %: 100 Other %: 100 Exception: 0 Adjust: Adjust RMV: 0

Floors

Type	Class	Display Group	Floor Size	Beds	Baths	Yr Blt	Eff Yr Blt	Inventory	Exception: Y N
Multi-Purpose Bldg	5	Finished	192	0	0	2019	2019		Y N

Accessories

Description	Class	Size SqFt	Eff Yr Blt	RMV	Quantity
No accessory data available					

FINISHED 7-19-23

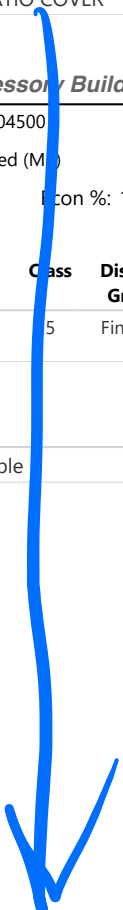

ACCOUNT # 352009 DATE: 9-14-23 RMV CLASS (N) PROP CLASS _____
 MTL _____ APPR AW TAG Y (N)
 COMMENTS: _____

RESIDENCE / MANUFACTURED STRUCTURES

ACCESSORY IMPROVEMENTS / OUTBUILDINGS

STAT 152 QLTY + - FLOOR ATTN
 AREA 364 EFF AREA 364 BED _____
 ROOF + HVAC +
 BATH PKG: _____ BATH BATH + 1/2 BTH
 FIREPLACE: _____
 KITCHEN - + ADD HVAC
 YR BLT 2023 EFF YR 2023 ECON _____
 % COMP _____ % GOOD _____ FUNC _____
 EXCEPT (Y) N LUMP SUM: _____
 MISC: _____
 YI CLASS _____ F G A E
 SKIRT - LIN FT _____
 COMMENT: _____

STAT _____ QLTY + - FLOOR _____
 AREA _____ EFF AREA _____ BED _____
 ROOF + HVAC +
 BATH PKG: _____ BATH BATH + 1/2 BTH
 FIREPLACE: _____
 KITCHEN - +
 YR BLT _____ EFF YR _____ ECON _____
 % COMP _____ % GOOD _____ FUNC _____
 EXCEPT Y N LUMP SUM: _____
 MISC: _____
 YI CLASS _____ F G A E
 SKIRT - LIN FT _____
 COMMENT: _____

STAT _____ QLTY + - FLOOR _____
 AREA _____ EFF AREA _____ BED _____
 ROOF + HVAC +
 BATH PKG: _____ BATH BATH + 1/2 BTH
 FIREPLACE: _____
 KITCHEN - +
 YR BLT _____ EFF YR _____ ECON _____
 % COMP _____ % GOOD _____ FUNC _____
 EXCEPT Y N LUMP SUM: _____
 MISC: _____
 YI CLASS _____ F G A E
 SKIRT - LIN FT _____
 COMMENT: _____

TYPE _____
 STAT / CLASS _____
 SIZE _____
 FAIR
 AVERAGE
 GOOD
 EXCELLENT
 BATH _____
 YR BLT _____
 EFF YR _____
 % COMP _____
 EXCEPT Y N
 MISC: _____
 COMMENT: _____

TYPE _____
 STAT / CLASS _____
 SIZE _____
 FAIR
 AVERAGE
 GOOD
 EXCELLENT
 BATH _____
 YR BLT _____
 EFF YR _____
 % COMP _____
 EXCEPT Y N
 MISC: _____
 COMMENT: _____

TYPE _____
 STAT / CLASS _____
 SIZE _____
 FAIR
 AVERAGE
 GOOD
 EXCELLENT
 BATH _____
 YR BLT _____
 EFF YR _____
 % COMP _____
 EXCEPT Y N
 MISC: _____
 COMMENT: _____

TYPE _____
 STAT / CLASS _____
 SIZE _____
 FAIR
 AVERAGE
 GOOD
 EXCELLENT
 BATH _____
 YR BLT _____
 EFF YR _____
 % COMP _____
 EXCEPT Y N
 MISC: _____
 COMMENT: _____

SKETCH/AREA TABLE ADDENDUM

SUBJECT INFO

File No.: 352009 Parcel No.: 061E29A 02100
 Property Address: 16992 SILVER OAKS LN NE
 City: SILVERTON County: MARION State: OR ZipCode: 97381
 Owner:
 Client: Client Address:
 Appraiser Name: Inspection Date:

SKETCH

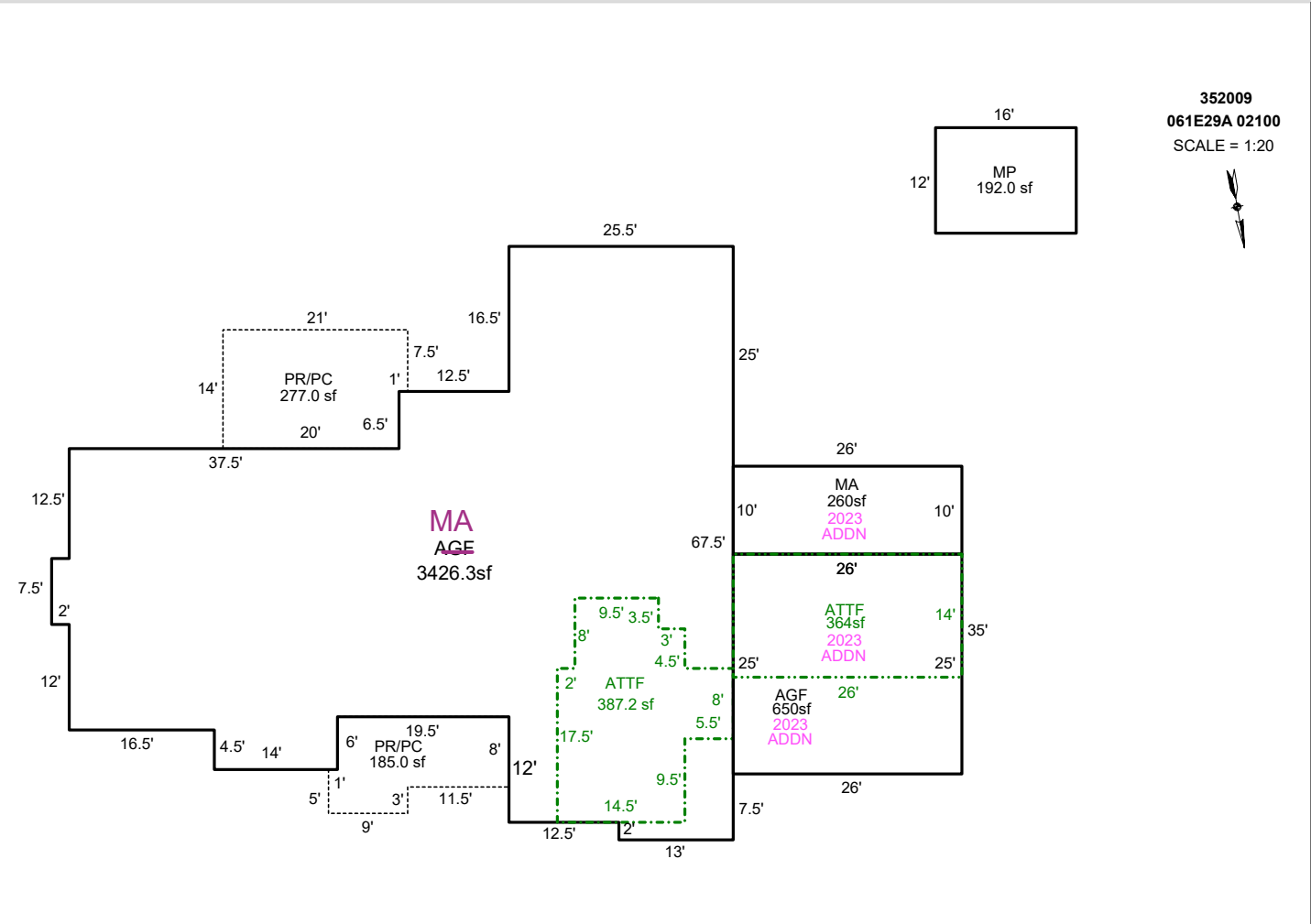

AREA CALCULATIONS SUMMARY

Code	Description	Factor	Net Size	Perimeter	Net Totals
GBA1	MP	1.0	192.0	56.0	192.0
GLA1	MA	1.0	260.0	72.0	260.0
GLA2	ATTF	1.0	364.0	80.0	364.0
GAR	AGF	1.0	3426.3	302.0	
	ATTF	1.0	387.3	91.0	
	AGF	1.0	650.0	102.0	4463.5

COMMENT TABLE 1

DRAWN BY JRONDEMA 12/21/18
 UPD BY PH 10.15.19
 UPDATED BY CJURAN 05/04/2023 555-23-001912
 UPDATED BY WWILLIAMS 11.06.23
 UPDATED BY CJURAN 11/20/2023

COMMENT TABLE 2

09.25.19 SR #94
 CL 09.14.23
 CL 11/02/2023

COMMENT TABLE 3

TAGS
 TAGS L3
 TAGS L3

Net LIVABLE cnt 2 (rounded) 624
 Net BUILDING cnt 1 (rounded) 192

