

Summary Lead Appr: **WW** Clerk: _____ Lead Clerk: _____ Appr: _____ Print Date:

7/31/2023

Acct ID: 345993 MTL: 061E20C003200 **② 9-14-23** Date: **9-14-23** Appr: **LUKE** Prop Class: **400** **401** RMV Prop Class: **400**
 Situs: 7161 ELMERS CT NE SILVERTON OR 97381 **③ 12-5-23** MaSaNh: 01 06 008 Unit: 21176 Year: **2024**
 Last Date Appraised: 03/21/2023 Appraiser: CLINT LUKE Retag: **Y** Tag info: 2024 - NEW CONSTRUCTION (Residence)
 Owner: **NOVY, ROBERT** Roll Type: R
 Cycle **①** Tag Sales Verification Other: _____ Inspection level: 1 **00** 2 3 4 LCB TTO INSP **INPUT 12-8-23 LUKE** AV: 120310
 RMV Land: 210730 RMV Imp: 0 RMV Total: 210730 MAV: 120310 MSAV: 0 SAV: 0
 Comment: 23-24 L4 3/21/23 CLUKE **ADD NEW MA, OSD** **WWW**
 LEVEL 4 C19 4-21-20 SR94 **Run TAG**

Notations

No notation data available.

OSDs

No OSD data available.

Land **Chris 12/14/23**

Site: 1	Code Area: 40500	Size: 0.32 Acres	Use Code: 004	Zone: NREST	SAV Use:	Exception: 0
Class: 2BD	Value Source: Rural at MKT	Description: TWO BENCH DRY	RMV: 38080	Exception: Y	N	
Adjustment(s): GSOIL, FSOIL		Fire Patrol: SA004		Description: FIRE PATROL		
Comments: 21-22: #94 CYCLE C19, NO CHG //08-09: DISQ FARM USE / 400020 06-07: RECALC SETUP;#10 08-01-05						
Site: 2	Code Area: 40500	Size: 1.68 Acres	Use Code: 004	Zone: NREST	SAV Use:	Exception: 0
Class: 6B	Value Source: Rural at MKT	Description: SIX BENCH	RMV: 172650	Exception: Y	N	
Adjustment(s): GSOIL, FSOIL		Fire Patrol: SA004		Description: FIRE PATROL		
Comments: 21-22: #94 CYCLE C19, NO CHG //08-09: DISQ FARM USE / 400020 06-07: RECALC SETUP;#10 08-01-05						

Improvements - Residence / Manufactured Structures

No residence or manufactured structure improvement data available.

Improvements - Accessory Buildings

No improvement data available for all other stat class types.

ACCOUNT # 345993 DATE: 12-1-23 RMV CLASS _____ PROP CLASS _____
 MTL _____ APPR EVER TAG Y N
 COMMENTS: _____

RESIDENCE / MANUFACTURED STRUCTURES

ACCESSORY IMPROVEMENTS / OUTBUILDINGS

STAT 5 QLTY + - FLOOR MA
 AREA 2455 EFF AREA 2455 BED 3
 ROOF + HVAC +
 BATH PKG: 2 BATH BATH + 1/2 BTH
 FIREPLACE: _____
 KITCHEN - + ALL AVE
 YR BLT 2023 EFF YR 2023 ECON _____
 % COMP 100 % GOOD _____ FUNC _____
 EXCEPT Y N LUMP SUM: _____
 MISC: _____
 YI CLASS 5 F G A E
 SKIRT - LIN FT _____
 COMMENT: _____

TYPE AGF
 STAT / CLASS _____
 SIZE 910
 FAIR
AVERAGE
 GOOD
 EXCELLENT
 BATH _____
 YR BLT 2023
 EFF YR _____
 % COMP 100
 EXCEPT Y N
 MISC: _____
 COMMENT: _____

TYPE _____
 STAT / CLASS _____
 SIZE _____
 FAIR
 AVERAGE
 GOOD
 EXCELLENT
 BATH _____
 YR BLT _____
 EFF YR _____
 % COMP _____
 EXCEPT Y N
 MISC: _____
 COMMENT: _____

STAT 5 QLTY + - FLOOR HTF
 AREA 423 EFF AREA _____ BED _____
 ROOF + HVAC +
 BATH PKG: 1 BATH BATH + 1/2 BTH
 FIREPLACE: _____
 KITCHEN - + AVE HEAT
 YR BLT 2023 EFF YR 2023 ECON _____
 % COMP _____ % GOOD _____ FUNC _____
 EXCEPT Y N LUMP SUM: _____
 MISC: _____
 YI CLASS _____ F G A E
 SKIRT - LIN FT _____
 COMMENT: _____

TYPE _____
 STAT / CLASS _____
 SIZE _____
 FAIR
 AVERAGE
 GOOD
 EXCELLENT
 BATH _____
 YR BLT _____
 EFF YR _____
 % COMP _____
 EXCEPT Y N
 MISC: _____
 COMMENT: _____

TYPE _____
 STAT / CLASS _____
 SIZE _____
 FAIR
 AVERAGE
 GOOD
 EXCELLENT
 BATH _____
 YR BLT _____
 EFF YR _____
 % COMP _____
 EXCEPT Y N
 MISC: _____
 COMMENT: _____

STAT _____ QLTY + - FLOOR _____
 AREA _____ EFF AREA _____ BED _____
 ROOF + HVAC +
 BATH PKG: _____ BATH BATH + 1/2 BTH
 FIREPLACE: _____
 KITCHEN - +
 YR BLT _____ EFF YR _____ ECON _____
 % COMP _____ % GOOD _____ FUNC _____
 EXCEPT Y N LUMP SUM: _____
 MISC: _____
 YI CLASS _____ F G A E
 SKIRT - LIN FT _____
 COMMENT: _____

PLANS RETURNED

SKETCH/AREA TABLE ADDENDUM

SUBJECT INFO

File No.: 345993 Parcel No.: 061E20C003200
 Property Address: LOT #3 ELMERS COURT NE
 City: SILVERTON County: MARION State: OR ZipCode:
 Owner:
 Client Address:
 Appraiser Name: Inspection Date:

SKETCH

345993
061E20C003200
 SCALE = 1:20

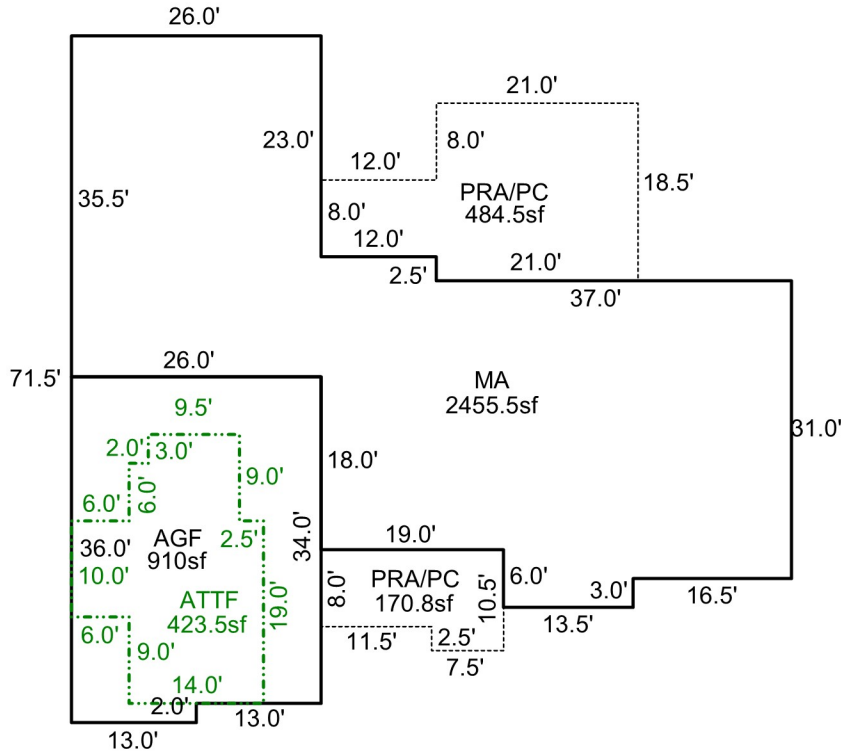

Sketch by Apex Sketch

AREA CALCULATIONS SUMMARY

Code	Description	Factor	Net Size	Perimeter	Net Totals
GLA1	MA	1.0	2455.5	269.0	2455.5
GLA2	ATTF	1.0	423.5	96.0	423.5
GAR	AGF	1.0	910.0	124.0	910.0
P/P	PRA/PC	1.0	484.5	103.0	655.3
	PRA/PC	1.0	170.8	59.0	

COMMENT TABLE 1

APEX BY CJURAN 03/20/2023 555-22-011644

COMMENT TABLE 2

COMMENT TABLE 3

Net LIVABLE cnt 2 (rounded) 2,879



9/14/23



9/14/23



9/14/23



9/14/23



9/14/23