

Summary Lead Appr: **WW** Clerk: **Chris 3/20/24** Lead Clerk: _____ Appr: **MBC** Print Date: 7/31/2023

Acct ID: 330763 MTL: 093W35CD00800 Date: **9/7/23** Appr: **MBC** Prop Class: 401 RMV Prop Class: 401
Situs: 14952 LAUREL LN SE JEFFERSON OR 97352 MaSaNh: 07 06 000 Unit: 55164 Year: **2023**
Last Date Appraised: 12/07/2023 Appraiser: MATT LORD Retag: Y **N** Tag info: 2024 - Tags/Permit (Completion) **2024**
Owner: MCGEHEE, CATHERINE DIANE Roll Type: R
Cycle **Tag** Sales Verification Other: _____ Inspection level: 1 2 **3** 4 LCB TTO **INSP** AV: 505130
RMV Land: 178740 RMV Imp: 424720 RMV Total: 603460 MAV: 35410 MSAV: 0 SAV: 0
Comment: 23-24 L2 12.07.23 MDL

INPUT MDL 12/6/23

WW

Notations **24.25: ✓ completion 22-004136 100% complete / PUISTAB**

No notation data available.

OSDs

Count	Code	Description	RMV	Code Area	Exception
1	MKTA	OSD - AVERAGE	45000	14530	45000

Land

Site: 1 Code Area: 14530 Size: 1.50 Acres Use Code: 004 Zone: NREST SAV Use: Exception: 0
 Class: 4BD Value Source: Rural at MKT Description: FOUR BENCH DRY RMV: 133740 Exception: Y N
 Adjustment(s): Fire Patrol: Description:
 Comments: 18-19: #11 CYCLE WORK, NO CHG //8-7-08(GW39): Maintain flat value until road and utility improvements are completed and lots can be sold. Then establish new RMV and process SUBE exception//03-04: L & L SUBDIVISION MERGING INTO SURROUNDING AREA 03-04: REAPPRAISAL //03-04: T03-51G REDUCTION OF MKT AND AV FOR LAND,FREEZE VALUE TILL 1-1-05 //04-05: CHG OF LAND SCHEDULE PER #29

Improvements - Residence / Manufactured Structures

Bldg: 1 Code Area: 14530 Stat Class: 151 Year Blt: 2022 Eff Year Blt: **2022** Sq.Ft: 3946 % Complete: **45**
 Desc: One Story Only Dimensions: RMV: 424720 **100**
 Func Obsc: 100 Econ %: 100 Other %: 100 Exception: 424720 Adjust: Adjust RMV: 0

Floors

Type	Class	Display Group	Floor Size	Beds	Baths	Yr Blt	Eff Yr Blt	Inventory	Exception
First Floor	5	Finished	2200	0	0	2022	0		Exception: Y N
First Floor	5	Finished	1746	0	0	2022	0		Exception: Y N
Garage Attached	5	Finished	568	0	0	2022	0		Exception: Y N
Garage Attached	5	Finished	873	0	0	2022	0		Exception: Y N

Accessories **vt 5A**

Description	Class	Size SqFt	Eff Yr Blt	RMV	Quantity
No accessory data available					

Improvements - Accessory Buildings

No improvement data available for all other stat class types.

SKETCH/AREA TABLE ADDENDUM

SUBJECT INFO

File No.: 330763 Parcel No.: 093W35CD00800
 Property Address: 14952 LAUREL LANE SE
 City: JEFFERSON County: MARION State: OR ZipCode: 97352
 Owner:
 Client:
 Client Address:
 Appraiser Name: Inspection Date:

SKETCH

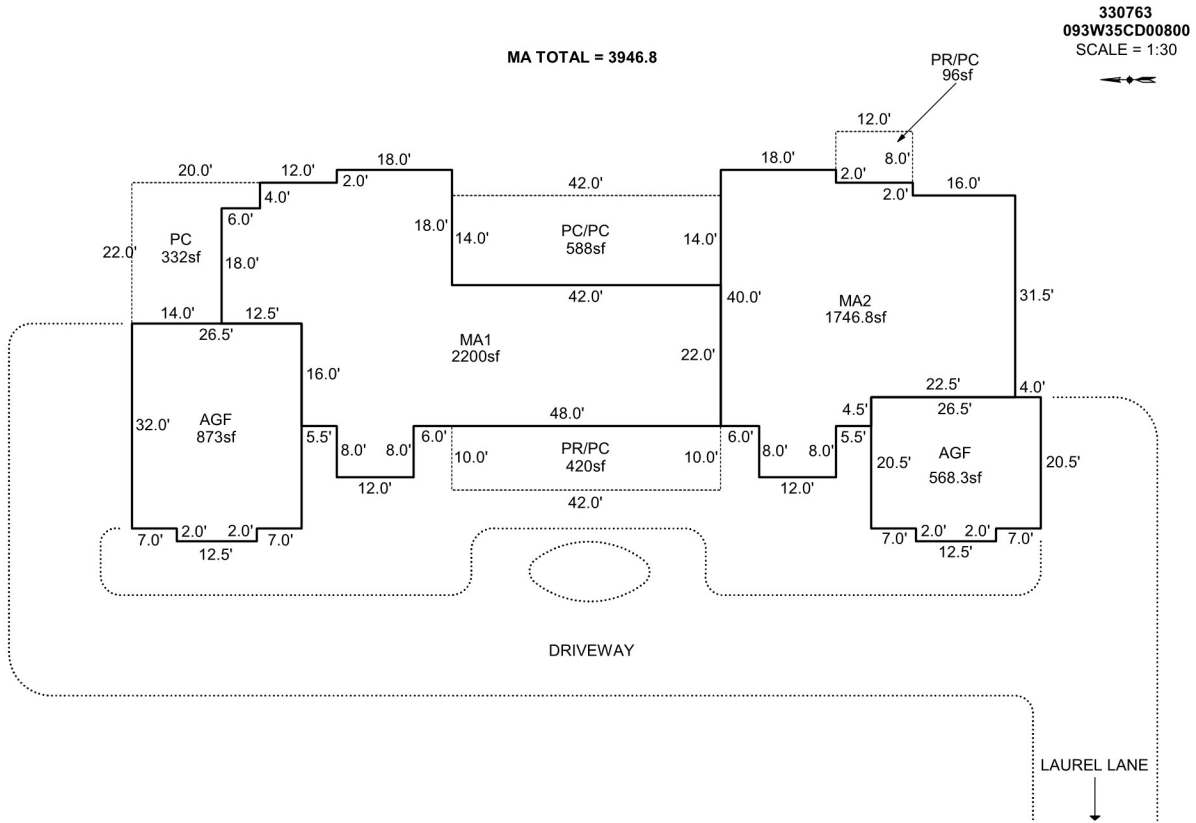

AREA CALCULATIONS SUMMARY

Code	Description	Factor	Net Size	Perimeter	Net Totals
GLA1	MA2	1.0	1746.8	188.0	
	MA1	1.0	2200.0	252.0	3946.8
GAR	AGF	1.0	873.0	121.0	
	AGF	1.0	568.3	98.0	1441.3
P/P	PC/PC	1.0	588.0	112.0	
	PR/PC	1.0	96.0	40.0	
	PC	1.0	332.0	84.0	
	PR/PC	1.0	420.0	104.0	1436.0

COMMENT TABLE 1

APEX BY CJURAN 09/19/2022 555-22-004136

COMMENT TABLE 2

COMMENT TABLE 3

Net LIVABLE cnt 2 (rounded) 3,947

SKETCH/AREA TABLE ADDENDUM

SUBJECT INFO

File No.: 330763 Parcel No.: 093W35CD00800
 Property Address: 14952 LAUREL LANE SE
 City: JEFFERSON County: MARION State: OR ZipCode: 97352
 Owner:
 Client Address:
 Appraiser Name: Inspection Date:

SKETCH

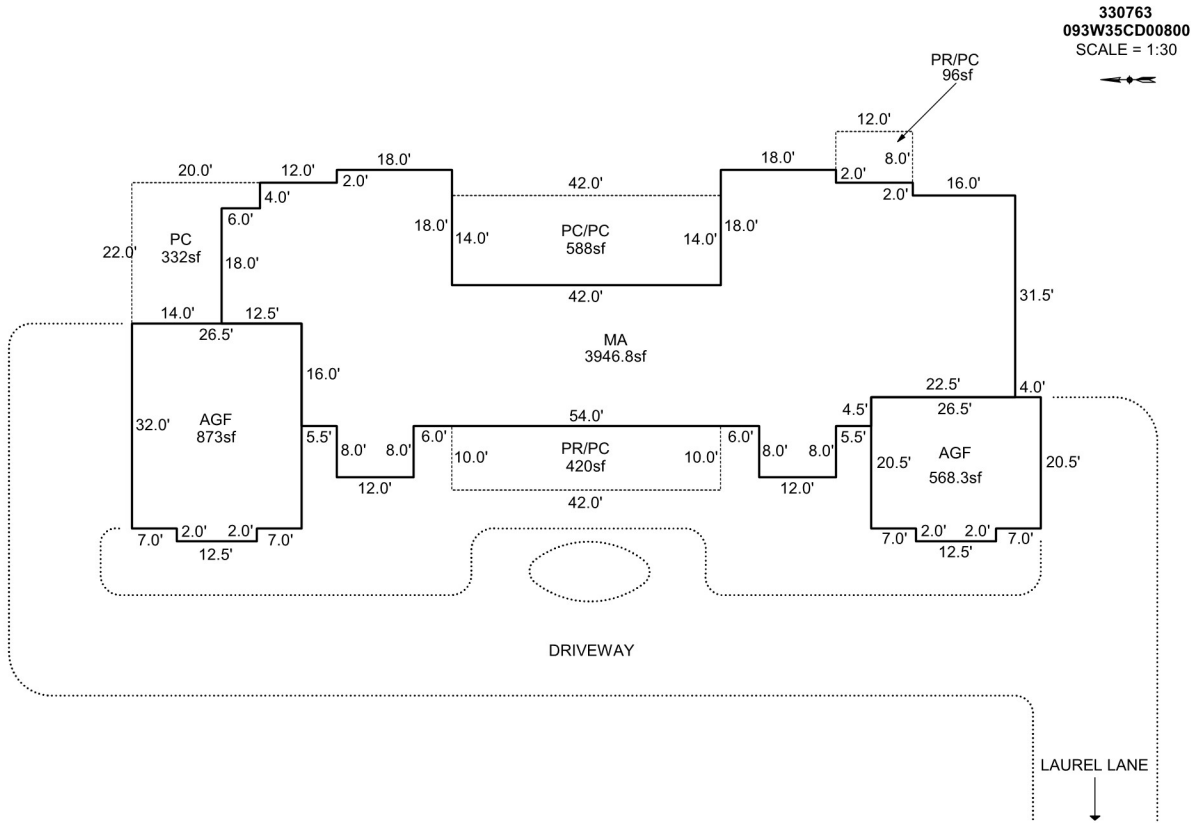

Sketch by Apex Sketch

AREA CALCULATIONS SUMMARY

Code	Description	Factor	Net Size	Perimeter	Net Totals
GLA1	MA	1.0	3946.8	396.0	3946.8
GAR	AGF	1.0	873.0	121.0	
	AGF	1.0	568.3	98.0	1441.3
P/P	PC/PC	1.0	588.0	112.0	
	PR/PC	1.0	96.0	40.0	
	PC	1.0	332.0	84.0	
	PR/PC	1.0	420.0	104.0	1436.0

COMMENT TABLE 1

APEX BY CJURAN 09/19/2022 555-22-004136

COMMENT TABLE 2

COMMENT TABLE 3

Net LIVABLE cnt 1 (rounded) 3,947



R330763
8/15/2018