

Acct ID: 535326 MTL: 092W160000800 Date: 11/9/23 Appr: MDL Prop Class: 581 RMV Prop Class: 501  
 Situs: 6514 HUNSAKER RD SE TURNER OR 97392 MaSaNh: 07 06 000 Unit: 53549 Year: ~~2023~~  
 Last Date Appraised: 11/08/2022 Appraiser: MATT LORD Retag: Y (N) Tag info: 2024 - Tags/Permit (Completion) 2024  
 Owner: KATHY L BRIDGES TR & BRIDGES, KATHY L TRE Roll Type: R  
 Cycle Tag Sales Verification Other: \_\_\_\_\_ Inspection level: 1 2 3 4 LCB TTO INSP AV: 458626  
 RMV Land: 213500 RMV Imp: 979990 RMV Total: 1193490 MAV: 403330 MSAV: 58796 SAV: 104877  
 Comment: 23-24: L1 11.8.22 MDL Lated Exception  
 22-23: LEVEL 4 CL 8.24.21  
 LEVEL 2 12.2.19 CL10

Notations 24-25: SFD 100% Pull TAB 21-005272 INPUT 12/5/23 MDL WW

RP/MS	Code	Description
RP	ZONED	FARM EFU ZONED

Amy 4/2/24

OSDs Chris 4/2/24 Change all farm use acres to wasteland. Used in conjunction with farmland on 535327.

Count	Code	Description	RMV	Code Area	Exception
1	SAA	SA OSD - AVERAGE	45000	05595	0
1	SAF	SA OSD - FAIR	35000	05595	0

Land

Site: 2	Code Area: 05595	Size: 1.00 Acres	Use Code: 005	Zone: REST	SAV Use: 011	Exception: 0
Class: 4BD	Value Source: Wildlife Habitat Conservation	Description: FOUR BENCH DRY	RMV: 3950	Exception: Y	N	
Adjustment(s):	GSOIL, WASTE	Fire Patrol:	Description:			
Comments:	Liability year - 2009 / 550190					
Site: 3	Code Area: 05595	Size: 1.00 Acres	Use Code: 005	Zone: REST	SAV Use: 011	Exception: 0
Class: 4BD	Value Source: Wildlife Habitat Conservation	Description: FOUR BENCH DRY	RMV: 3950	Exception: Y	N	
Adjustment(s):	GSOIL, WASTE	Fire Patrol:	Description:			
Comments:	Liability year - 2009 / 550190					
Site: 5	Code Area: 05595	Size: 3.68 Acres	Use Code: 005	Zone: REST	SAV Use: 011	Exception: 0
Class: 2BI	Value Source: Farm Use - EFU	Description: TWO BENCH IRR	RMV: 15990	Exception: Y	N	
Adjustment(s):	GSOIL, WASTE	Fire Patrol:	Description:			
Comments:	Liability year - 1974 / 550190					
Site: 6	Code Area: 05595	Size: 25.95 Acres	Use Code: 005	Zone: REST	SAV Use: 011	Exception: 0
Class: 4BD	Value Source: Farm Use - EFU	Description: FOUR BENCH DRY	RMV: 102530	Exception: Y	N	
Adjustment(s):	GSOIL, WASTE	Fire Patrol:	Description:			
Comments:	Liability year - 1974 / 550190: 01-02: COMBINED LAND SEGS - SAME SOIL CLASS, SAME LIAB YR, 55.95 TTL ACRES					
Site: 7	Code Area: 05595	Size: 33.48 Acres	Use Code: 005	Zone: REST	SAV Use: 011	Exception: 0
Class: WST	Value Source: Wetland Reserve Program	Description: Rural WASTELAND	RMV: 3970	Exception: Y	N	
Adjustment(s):	GSOIL, WASTE	Fire Patrol:	Description:			
Comments:	Liability year - 1980 / 14-15: CORRECTED LAND TYPE FROM WETLANDS TO WRP, COMBINED LIKE SEGS					
Site: 8	Code Area: 05595	Size: 26.28 Acres	Use Code: 005	Zone: REST	SAV Use: 011	Exception: 0
Class: WST	Value Source: Wetland Reserve Program	Description: Rural WASTELAND	RMV: 3110	Exception: Y	N	
Adjustment(s):	GSOIL, WASTE	Fire Patrol:	Description:			
Comments:	Liability year - 2010 / 14-15: CORRECTED LAND TYPE TO WRP// 550190: 01-02: COMBINED LAND SEGS - SAME SOIL CLASS, SAME LIAB YR, 55.95 TTL ACRES					

Improvements - Residence / Manufactured Structures

Bldg: 1	Code Area: 05595	Stat Class: 141 -	Year Blt: 1969	Eff Year Blt: 1992	Sq.Ft: 2677	% Complete: 100
Desc: One Story Only	Func Obsc: 100	Econ %: 100	Other %: 100	Exception: 0	Adjust: Adjust RMV: 0	Dimensions: RMV: 425530

Floors

Type	Class	Display Group	Floor Size	Beds	Baths	Yr Blt	Eff Yr Blt	Inventory	Exception: Y N
First Floor	4 -	Finished	2677	4	FB-2	1969	1992	BATH - 2, ROOF, HVAC, KIT-	Y N
Garage Attached	4	Finished	754	0	0	2012	2012	ROOF	Y N
Carport Attached	4	Unfinished	200	0	0	2012	2012	ROOF	Y N

Accessories

Description	Class	Size SqFt	Eff Yr Blt	RMV	Quantity	Exception: Y N
ENCLOSED PORCH	4	171	1992	4942	1	Y N

Bldg: 6	Code Area: 05595	Stat Class: 152	Year Blt: 2017	Eff Year Blt: 2017	Sq.Ft: 4617	% Complete: <u>55</u> <u>100</u>
Desc: Multi Story above grade	Dimensions: RMV: 495860					

Func Obsc: 100

Econ %: 100

Other %: 100

Exception: 0

Adjust:

Adjust RMV: 0

**Floors**

Type	Class	Display Group	Floor Size	Beds	Baths	Yr Blt	Eff Yr Blt	Inventory	Exception: Y N
First Floor	5	Finished	2427	2	FB-2	2017	2017	ROOF, HVAC, KIT-, BATH - 2	Exception: Y N
Second Floor	5	Finished	1499	1	FB-1	2017	2017	BATH+, HVAC, BATH - 1	Exception: Y N
Attic	5	Finished	691	1	FB-1	2017	2017	HVAC, BATH - 1	Exception: Y N
Garage Attached	5	Finished	1143	0	0	2017	2017	ROOF	Exception: Y N

**Accessories**

Description	Class	Size SqFt	Eff Yr Blt	RMV	Quantity
No accessory data available					

Bldg: 9 Code Area: 05595 Stat Class: 107 Year Blt: Eff Year Blt: Sq.Ft: 0 % Complete: 100  
 Desc: Yard Improvements Dimensions: RMV: 10630  
 Func Obsc: 100 Econ %: 100 Other %: 100 Exception: 0 Adjust: Adjust RMV: 0

**Floors**

Type	Class	Display Group	Floor Size	Beds	Baths	Yr Blt	Eff Yr Blt	Inventory	Exception: Y N
No floor data available									

**Accessories**

Description	Class	Size SqFt	Eff Yr Blt	RMV	Quantity
YARD IMPROVEMENTS AVERAGE <i>LOOD</i>	4	1	0	8505	1

**Improvements - Accessory Buildings**

Bldg: 2 Code Area: 05595 Stat Class: 353 Year Blt: 1988 Eff Year Blt: 1988 Sq.Ft: 1728 % Complete: 100  
 Desc: Machine Shed (MS) Dimensions: 72x24 RMV: 9570  
 Func Obsc: 100 Econ %: 100 Other %: 100 Exception: 0 Adjust: Adjust RMV: 0

**Floors**

Type	Class	Display Group	Floor Size	Beds	Baths	Yr Blt	Eff Yr Blt	Inventory	Exception: Y N
Machine Shed	5	Finished	1728	0	0	1988	1988	FAIR	Exception: Y N

**Accessories**

Description	Class	Size SqFt	Eff Yr Blt	RMV	Quantity
No accessory data available					

Bldg: 3 Code Area: 05595 Stat Class: 351 Year Blt: 2005 Eff Year Blt: 2005 Sq.Ft: 720 % Complete: 100  
 Desc: General Purpose Building (GB) Dimensions: 40x18 RMV: 13260  
 Func Obsc: 100 Econ %: 100 Other %: 100 Exception: 0 Adjust: Adjust RMV: 0

**Floors**

Type	Class	Display Group	Floor Size	Beds	Baths	Yr Blt	Eff Yr Blt	Inventory	Exception: Y N
General Purpose Bldg	5	Finished	720	0	0	2005	2005	FAIR	Exception: Y N

**Accessories**

Description	Class	Size SqFt	Eff Yr Blt	RMV	Quantity
No accessory data available					

Bldg: 4 Code Area: 05595 Stat Class: 341 Year Blt: 1990 Eff Year Blt: 1990 Sq.Ft: 192 % Complete: 100  
 Desc: Multi Purpose Shed (MP) Dimensions: 16x12 RMV: 2220  
 Func Obsc: 100 Econ %: 100 Other %: 100 Exception: 0 Adjust: Adjust RMV: 0

**Floors**

Type	Class	Display Group	Floor Size	Beds	Baths	Yr Blt	Eff Yr Blt	Inventory	Exception: Y N
Multi-Purpose Bldg	5	Finished	192	0	0	1990	1990	FAIR	Exception: Y N

**Accessories**

Description	Class	Size SqFt	Eff Yr Blt	RMV	Quantity
No accessory data available					

Bldg: 5 Code Area: 05595 Stat Class: 351 Year Blt: 1987 Eff Year Blt: 1987 Sq.Ft: 1184 % Complete: 100  
 Desc: General Purpose Building (GB) Dimensions: 16x74 RMV: 3170  
 Func Obsc: 50 Econ %: 100 Other %: 100 Exception: 0 Adjust: Adjust RMV: 0

**Floors**

Type	Class	Display Group	Floor Size	Beds	Baths	Yr Blt	Eff Yr Blt	Inventory	Exception: Y N
General Purpose Bldg	4	Finished	1184	0	0	1987	1987	FAIR	Exception: Y N

**Accessories**

Description	Class	Size SqFt	Eff Yr Blt	RMV	Quantity
No accessory data available					

Bldg: 7 Code Area: 05595 Stat Class: 341 Year Blt: 1975 Eff Year Blt: 1975 Sq.Ft: 320 % Complete: 100  
 Desc: Multi Purpose Shed (MP) Dimensions: 16x20 RMV: 1930  
 Func Obsc: 100 Econ %: 100 Other %: 100 Exception: 0 Adjust: Adjust RMV: 0

**Floors**

Type	Class	Display Group	Floor Size	Beds	Baths	Yr Blt	Eff Yr Blt	Inventory
Multi-Purpose Bldg	5	Finished	320	0	0	1975	1975	FAIR
Exception: Y N								

**Accessories**

Description	Class	Size SqFt	Eff Yr Blt	RMV	Quantity
No accessory data available					

Bldg: 8 Code Area: 05595 Stat Class: 351 Year Blt: 2017 Eff Year Blt: 2017 Sq.Ft: 704 % Complete: 100  
 Desc: General Purpose Building (GB) Dimensions: 16x44 RMV: 17820  
 Func Obsc: 100 Econ %: 100 Other %: 100 Exception: 0 Adjust: Adjust RMV: 0

**Floors**

Type	Class	Display Group	Floor Size	Beds	Baths	Yr Blt	Eff Yr Blt	Inventory
General Purpose Bldg	5	Finished	704	0	0	2017	2017	FAIR
Exception: Y N								

**Accessories**

Description	Class	Size SqFt	Eff Yr Blt	RMV	Quantity
No accessory data available					

Bldg: 11 Code Area: 05595 Stat Class: 905 Year Blt: 2016 Eff Year Blt: 2016 Sq.Ft: 0 % Complete: 100  
 Desc: Rural Solar Panel/Array Dimensions: RMV: 0  
 Func Obsc: 100 Econ %: 100 Other %: 100 Exception: 0 Adjust: Adjust RMV: 0

**Floors**

Type	Class	Display Group	Floor Size	Beds	Baths	Yr Blt	Eff Yr Blt	Inventory
No floor data available								

**Accessories**

Description	Class	Size SqFt	Eff Yr Blt	RMV	Quantity
No accessory data available					

Bldg: 12 Code Area: 05595 Stat Class: 905 Year Blt: 2012 Eff Year Blt: 2012 Sq.Ft: 0 % Complete: 100  
 Desc: Rural Solar Panel/Array Dimensions: RMV: 0  
 Func Obsc: 100 Econ %: 100 Other %: 100 Exception: 0 Adjust: Adjust RMV: 0

**Floors**

Type	Class	Display Group	Floor Size	Beds	Baths	Yr Blt	Eff Yr Blt	Inventory
No floor data available								

**Accessories**

Description	Class	Size SqFt	Eff Yr Blt	RMV	Quantity
No accessory data available					

Bldg: 13 Code Area: 05595 Stat Class: 905 Year Blt: 2017 Eff Year Blt: 2017 Sq.Ft: 0 % Complete: 100  
 Desc: Rural Solar Panel/Array Dimensions: RMV: 0  
 Func Obsc: 100 Econ %: 100 Other %: 100 Exception: 0 Adjust: Adjust RMV: 0

**Floors**

Type	Class	Display Group	Floor Size	Beds	Baths	Yr Blt	Eff Yr Blt	Inventory
No floor data available								

**Accessories**

Description	Class	Size SqFt	Eff Yr Blt	RMV	Quantity
No accessory data available					

R35326  
092W16 00800  
SCALE=1:50

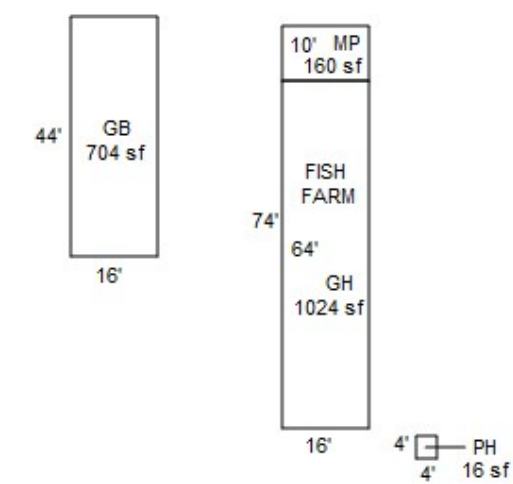
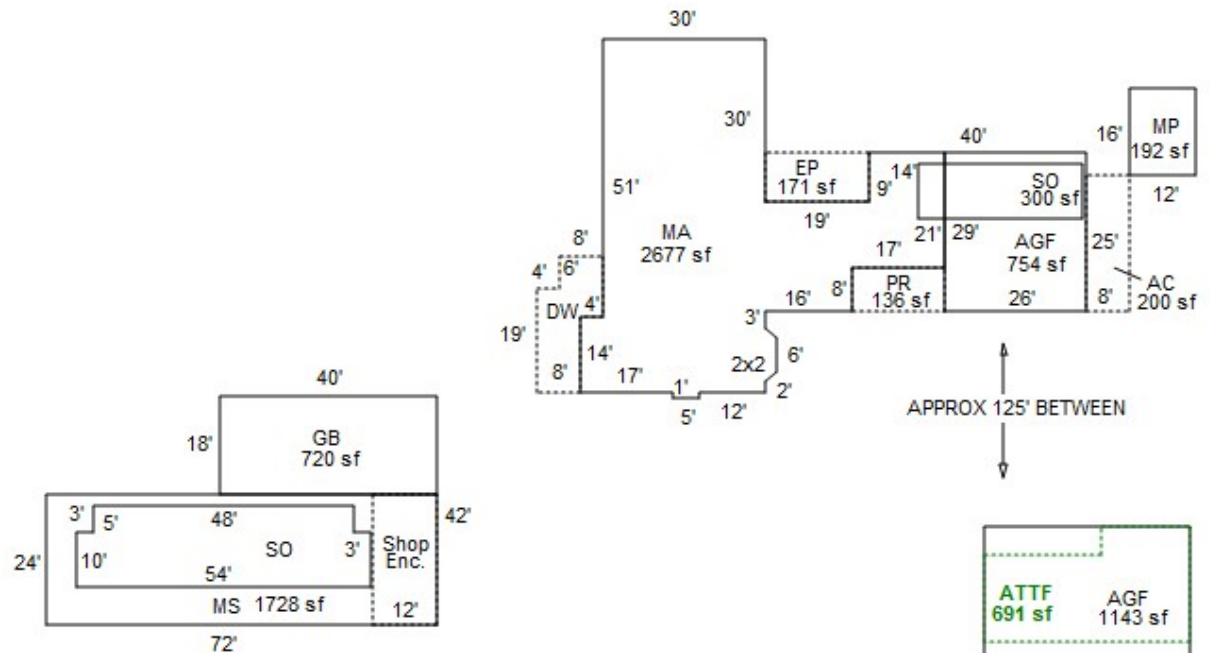

SEE PAGE 2 FOR DIMENSIONS

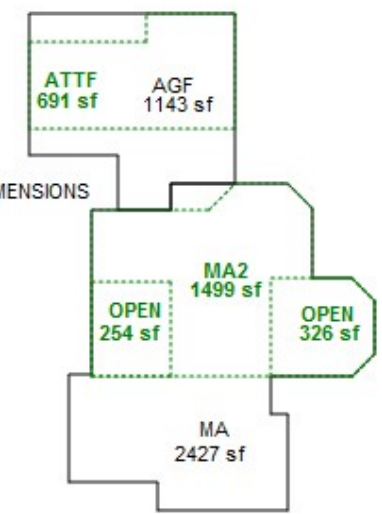

11/9/23 L3 MDL TAG

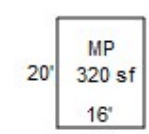

R35326  
092W16 00800



Tax Lot 700

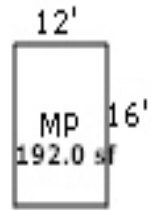
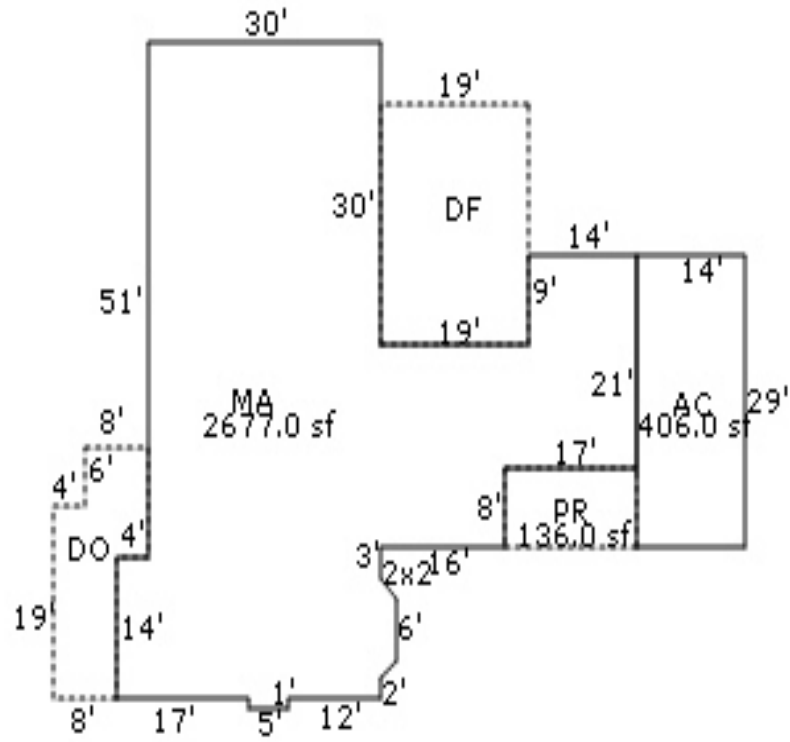
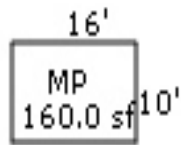
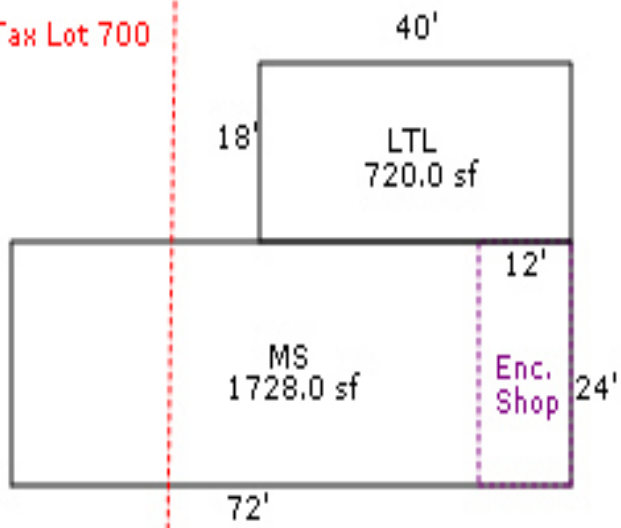

130 Feet

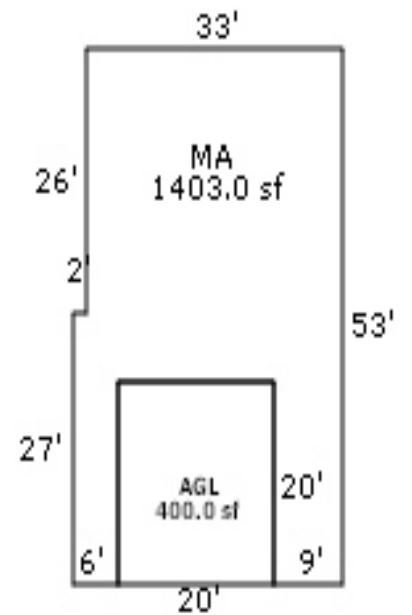





R35326 2427 sqft MA Front  
2020-12-10 L2

12/10/2020 0:04





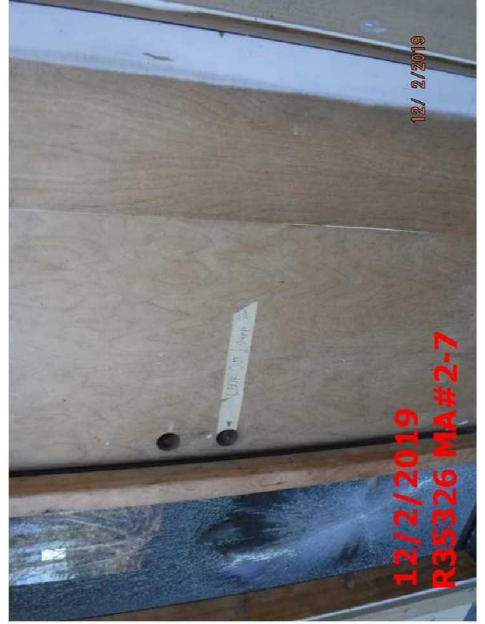
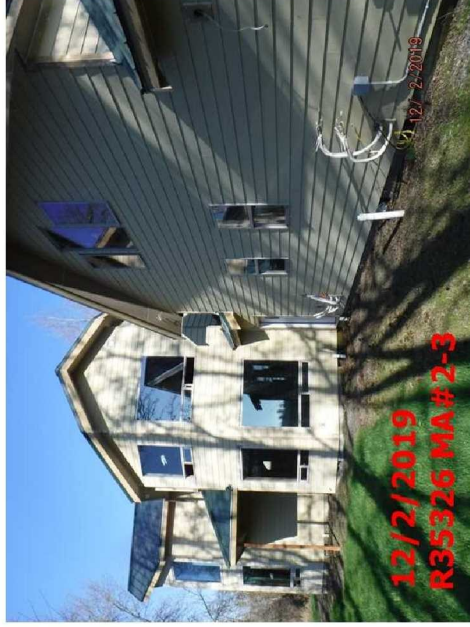
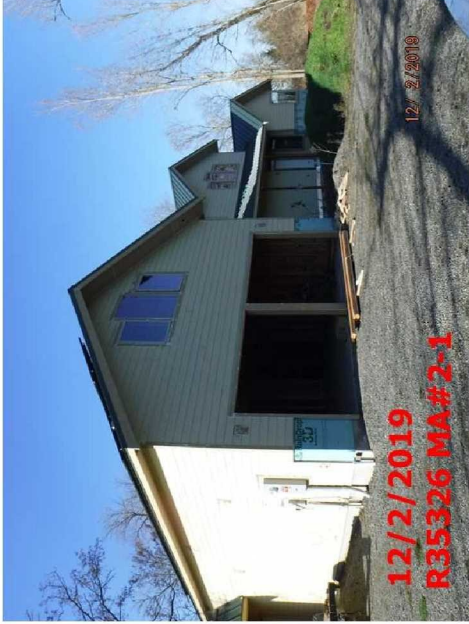



R35326 2427 sqft MA Front  
2020-12-10 L2

12/10/2020 0:04