

Acct ID: 530298 MTL: 082W23B005400 Date: **12/20/23** Appr: **MDL** Prop Class: 401 RMV Prop Class: 401
 Situs: 7858 MOSIER ST SE SALEM OR 97317 MaSaNh: 07 06 000 Unit: 43469 Year: 2024

Last Date Appraised: 06/06/2018 Appraiser: MATT LORD Retag: Y **(N)** Tag info: 2024 - Tags/Permit (Addition)
 Owner: WIENS, KEVIN LEROY JR & Roll Type: R
 Cycle **(Tag)** Sales Verification Other: **Allela** Inspection level: 1 2 3 **(4)** LCB TTO INSP AV: 451020
 RMV Land: 295030 RMV Imp: 409340 RMV Total: 704370 MAV: 451020 MSAV: 0 SAV: 0
 Comment: **23-006534 New 702 SF Deck paid by YI INPUT MDL 12/28/23**

Notations
 No notation data available.

OSDs

Count	Code	Description	RMV	Code Area	Exception
1	MKTA	OSD - AVERAGE	45000	05558	0

Land
 Site: 1 Code Area: 05558 Size: 5.20 Acres Use Code: 004 Zone: NREST SAV Use: Exception: 0
 Class: **4HD** Value Source: Rural at MKT Description: RMV: 250030 Exception: Y N
 Adjustment(s): Fire Patrol: Description:
 Comments: 2002-03 REAPPRAISAL.

Improvements - Residence / Manufactured Structures
 Bldg: 1 Code Area: 05558 Stat Class: 144 + Year Blt: 1976 Eff Year Blt: 1976 Sq.Ft: 2511 % Complete: 100
 Desc: Multi Story above grade with basement Dimensions: RMV: 378290
 Func Obsc: 100 Econ %: 100 Other %: 100 Exception: 0 Adjust: Adjust RMV: 0

Floors

Type	Class	Display Group	Floor Size	Beds	Baths	Yr Blt	Eff Yr Blt	Inventory	Exception
First Floor	4 +	Finished	1646	3	FB-2	1976	1976	FP, HVAC, KIT+, BATH - 2, ROOF	Y N
Attic	4 +	Finished	423	1	0	1976	1976	HVAC	Y N
Basement	4 +	Finished	442	0	FB-1	1976	1976	HVAC, BATH - 1	Y N
Garage Basement	4 +	Unfinished	862	0	0	1976	1976		Y N

Accessories

Description	Class	Size SqFt	Eff Yr Blt	RMV	Quantity	Exception
DECK	4	429	1980	7456	1	Y N
DECK	4	630	1980	9954	1	Y N

Improvements - Accessory Buildings
 Bldg: 2 Code Area: 05558 Stat Class: 351 Year Blt: 1976 Eff Year Blt: 1976 Sq.Ft: 640 % Complete: 100
 Desc: General Purpose Building (GB) Dimensions: 32x20 RMV: 2080
 Func Obsc: 100 Econ %: 100 Other %: 100 Exception: 0 Adjust: Adjust RMV: 0

Floors

Type	Class	Display Group	Floor Size	Beds	Baths	Yr Blt	Eff Yr Blt	Inventory	Exception
General Purpose Bldg	4	Finished	640	0	0	1976	1976	FAIR	Y N

Accessories

Description	Class	Size SqFt	Eff Yr Blt	RMV	Quantity
No accessory data available					

Bldg: 3 Code Area: 05558 Stat Class: 351 Year Blt: 2001 Eff Year Blt: 2001 Sq.Ft: 1400 % Complete: 100
 Desc: General Purpose Building (GB) Dimensions: 25x34 RMV: 21320
 Func Obsc: 100 Econ %: 100 Other %: 100 Exception: 0 Adjust: Adjust RMV: 0

Floors

Type	Class	Display Group	Floor Size	Beds	Baths	Yr Blt	Eff Yr Blt	Inventory	Exception
Attic	5	Finished	550	0	0	2001	2001		Y N
General Purpose Bldg	5	Finished	850	0	0	2001	2001	FAIR	Y N

Accessories

Description	Class	Size SqFt	Eff Yr Blt	RMV	Quantity
No accessory data available					

Bldg: 4 Code Area: 05558 Stat Class: 355 Year Blt: 2001 Eff Year Blt: 2001 Sq.Ft: 578 % Complete: 100
 Desc: Lean-to Heavy (LTH) Dimensions: RMV: 2620
 Func Obsc: 100 Econ %: 100 Other %: 100 Exception: 0 Adjust: Adjust RMV: 0

Floors

Type	Class	Display Group	Floor Size	Beds	Baths	Yr Blt	Eff Yr Blt	Inventory	
Lean-to Heavy Duty	5	Finished	578	0	0	2001	2001	FAIR	Exception: Y N

Accessories

Description	Class	Size SqFt	Eff Yr Blt	RMV	Quantity
No accessory data available					

Bldg: 5 Code Area: 05558 Stat Class: 341 Year Blt: 1990 Eff Year Blt: 1990 Sq.Ft: 192 % Complete: 100
 Desc: Multi Purpose Shed (MP) Dimensions: RMV: 1280
 Func Obsc: 100 Econ %: 100 Other %: 100 Exception: 0 Adjust: Adjust RMV: 0

Floors

Type	Class	Display Group	Floor Size	Beds	Baths	Yr Blt	Eff Yr Blt	Inventory	
Multi-Purpose Bldg	4	Finished	192	0	0	1990	1990		Exception: Y N

Accessories

Description	Class	Size SqFt	Eff Yr Blt	RMV	Quantity
No accessory data available					

Bldg: 6 Code Area: 05558 Stat Class: 355 Year Blt: 2001 Eff Year Blt: 2001 Sq.Ft: 432 % Complete: 100
 Desc: Lean-to Heavy (LTH) Dimensions: RMV: 1630
 Func Obsc: 100 Econ %: 100 Other %: 100 Exception: 0 Adjust: Adjust RMV: 0

Floors

Type	Class	Display Group	Floor Size	Beds	Baths	Yr Blt	Eff Yr Blt	Inventory	
Lean-to Heavy Duty	4	Finished	432	0	0	2001	2001		Exception: Y N

Accessories

Description	Class	Size SqFt	Eff Yr Blt	RMV	Quantity
No accessory data available					

Bldg: 7 Code Area: 05558 Stat Class: 355 Year Blt: 2001 Eff Year Blt: 2001 Sq.Ft: 240 % Complete: 100
 Desc: Lean-to Heavy (LTH) Dimensions: RMV: 910
 Func Obsc: 100 Econ %: 100 Other %: 100 Exception: 0 Adjust: Adjust RMV: 0

Floors

Type	Class	Display Group	Floor Size	Beds	Baths	Yr Blt	Eff Yr Blt	Inventory	
Lean-to Heavy Duty	4	Finished	240	0	0	2001	2001		Exception: Y N

Accessories

Description	Class	Size SqFt	Eff Yr Blt	RMV	Quantity
No accessory data available					

Bldg: 8 Code Area: 05558 Stat Class: 355 Year Blt: 2001 Eff Year Blt: 2001 Sq.Ft: 320 % Complete: 100
 Desc: Lean-to Heavy (LTH) Dimensions: RMV: 1210
 Func Obsc: 100 Econ %: 100 Other %: 100 Exception: 0 Adjust: Adjust RMV: 0

Floors

Type	Class	Display Group	Floor Size	Beds	Baths	Yr Blt	Eff Yr Blt	Inventory	
Lean-to Heavy Duty	4	Finished	320	0	0	2001	2001		Exception: Y N

Accessories

Description	Class	Size SqFt	Eff Yr Blt	RMV	Quantity
No accessory data available					

SKETCH/AREA TABLE ADDENDUM

SUBJECT INFO

File No.: 530298 Parcel No.: 082W23B 05400
 Property Address: 7858 MOSIER ST SE
 City: SALEM County: MARION State: OR ZipCode: 97317
 Owner:
 Client: Client Address:
 Appraiser Name: Inspection Date:

SKETCH

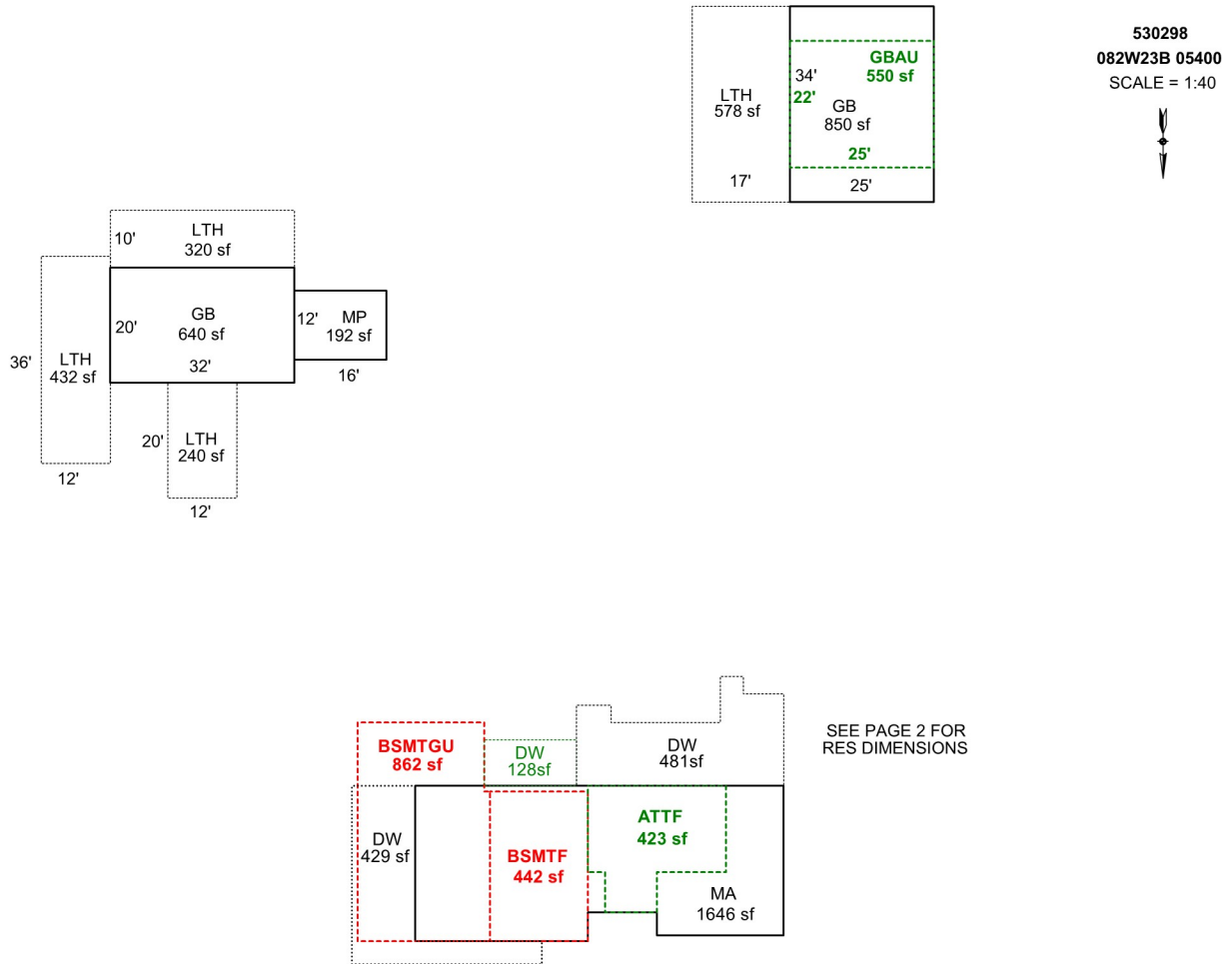

Sketch by Apex Sketch

AREA CALCULATIONS SUMMARY

Code	Description	Factor	Net Size	Perimeter	Net Totals
GBA1	GB	1.0	640.0	104.0	
	MP	1.0	192.0	56.0	
	GB	1.0	850.0	118.0	
	LTH	1.0	578.0	102.0	
	LTH	1.0	320.0	84.0	
	LTH	1.0	240.0	64.0	
	LTH	1.0	432.0	96.0	3252.0
GBA2	GBAU	1.0	550.0	94.0	550.0
GLA0	BSMTF	1.0	442.0	86.0	442.0
GLA1	MA	1.0	1646.0	190.0	1646.0
GLA2	ATTF	1.0	423.0	92.0	423.0
GAR	BSMTGU	1.0	862.0	122.0	862.0
P/P	DW	1.0	429.0	128.0	
	DW	1.0	128.0	48.0	
	DW	1.0	481.0	116.0	1038.0
	Net LIVABLE	cnt	2 (rounded)		2,511
	Net BUILDING	cnt	8 (rounded)		3,802

COMMENT TABLE 1

APEX BY CW 12/29/17
 UPDATED BY JRONDEMA 6/7/18
 UPDATED BY JRONDEMA 7/2/18
 UPDATED BY CJURAN 09/18/2023 23-006534

COMMENT TABLE 2

CL 10 6.6.18

COMMENT TABLE 3

SKETCH/AREA TABLE ADDENDUM

SUBJECT INFO

File No.: 530298 Parcel No.: 082W23B 05400
 Property Address: 7858 MOSIER ST SE
 City: SALEM County: MARION State: OR ZipCode: 97317
 Owner:
 Client: Client Address:
 Appraiser Name: Inspection Date:

SKETCH

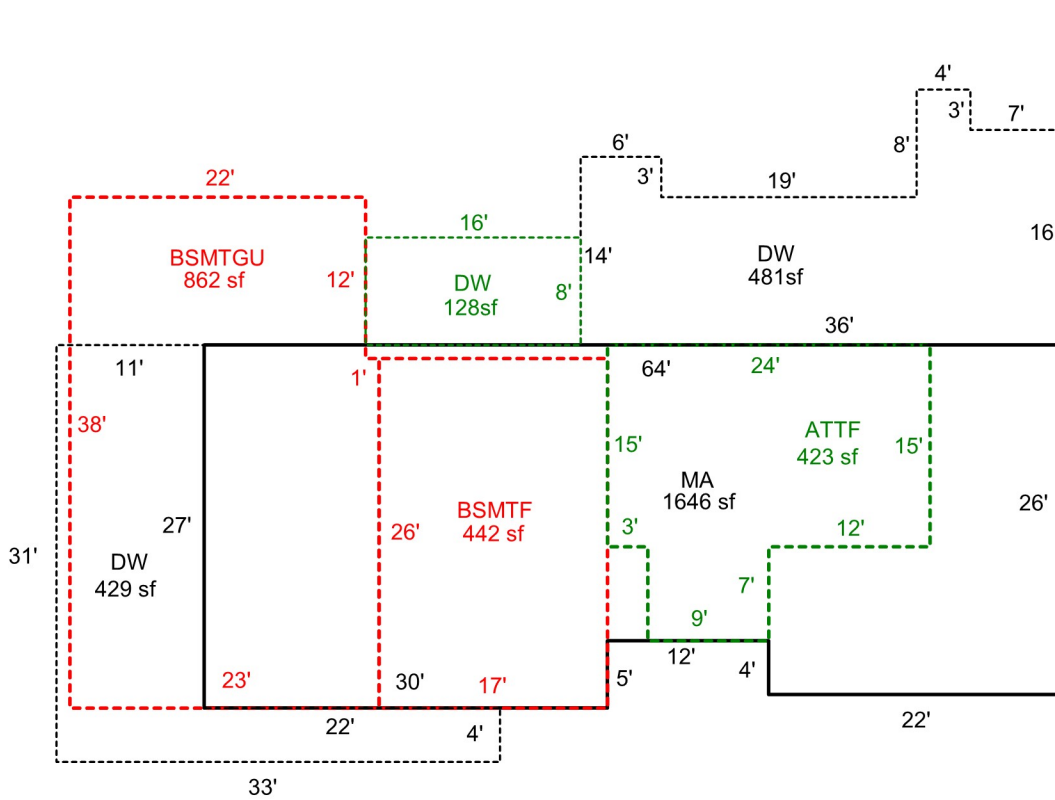

530298
082W23B 05400
 SCALE = 1:20

SEE PAGE 1 FOR ALL BLDGS

Sketch by Apex Sketch

AREA CALCULATIONS SUMMARY

COMMENT TABLE 1

Code	Description	Factor	Net Size	Perimeter	Net Totals
GLA0	BSMTF	1.0	442.0	86.0	442.0
GLA1	MA	1.0	1646.0	190.0	1646.0
GLA2	ATTF	1.0	423.0	92.0	423.0
GAR	BSMTGU	1.0	862.0	122.0	862.0
P/P	DW	1.0	429.0	128.0	
	DW	1.0	481.0	116.0	
	DW	1.0	128.0	48.0	1038.0

APEX BY CW 12/29/17
 UPDATED BY JRONDEMA 6/7/18
 UPDATED BY JRONDEMA 7/2/18
 UPDATED BY CJURAN 09/18/2023 23-006534

COMMENT TABLE 2

COMMENT TABLE 3

CL 10 6.6.18

Net LIVABLE cnt 2 (rounded) 2,511