

Acct ID: 539627 MTL: 081E050000100 Date: **9-21-23** Appr: **LUKE** Prop Class: 581 RMV Prop Class: 501
 Situs: 1601 DRIFT CREEK RD SE SUBLIMITY OR 97385 MaSaNh: 01 06 000 Unit: 44947 Year: 2023

Last Date Appraised: 01/04/2023 Appraiser: CLINT LUKE Retag: **Y** **N** Tag info: 2024 - Tags/Permit (Completion)

Owner: **NELSON LT & NELSON, RONALD N TRE &** Roll Type: R

Cycle: **Tag** Sales Verification Other: _____ Inspection level: 1 **2** 3 4 LCB TTO INSP AV: 181634

RMV Land: 632710 RMV Imp: 197540 RMV Total: 830250 MAV: 73910 MSAV: 19184 SAV: 46010

Comment: 23-24: L2 1.4.23 CL **DG 100% ADD [REDACTED] SOLAR & CD TO LTH PWR TAG**

Notations

RP/MS	Code	Description
RP	411	SEE ACCOUNT NOTES - 411
RP	STF	SMALL TRACT FORESTLAND
RP	ZONED	FARM EFU ZONED

INPUT IMPS 11/7/23 LUKE

OSDs

Count	Code	Description	RMV	Code Area	Exception
2	MKTN	OSD - NO LANDSCAPE	30000	04580	30000
2	SAF	SA OSD - FAIR	35000	04580	0

WW

Land Chris 1/4/24 Amy 1-25-24

Site: 2 Code Area: 04580 Size: 1.00 Acres Use Code: 005 Zone: REST SAV Use: 011 Exception: 0
 Class: 4BD Value Source: Farm Homesite Description: FOUR BENCH DRY **✓** RMV: 20940 Exception: Y N
 Adjustment(s): GSOIL Fire Patrol: SA004 Description: FIRE PATROL
 Comments: Liability year - 2009 / 4200188 **GRASS GROW ON HAY**

Site: 3 Code Area: 04580 Size: 11.92 Acres Use Code: 005 Zone: REST SAV Use: 011 Exception: 0
 Class: 2HD Value Source: Farm Use - EFU Description: **4BD** TWO HILL DRY RMV: 274560 Exception: Y N
 Adjustment(s): GSOIL Fire Patrol: SA004 Description: FIRE PATROL
 Comments: Liability year - 1974 / 4200188

Site: 4 Code Area: 04580 Size: 13.00 Acres Use Code: 005 Zone: REST SAV Use: 011 Exception: 0
 Class: STFC Value Source: Small Tract Forest land Description: SMALL TRACT FORESTLAND C **✓** RMV: 272210 Exception: Y N
 Adjustment(s): GSOIL **TRG 5-1-24 FOR REPLANT L2** Fire Patrol: SA004 Description: FIRE PATROL
 Comments: Liability year - 1976, STF - 2004 / 16-17: COMB LIKE SEGS // 08-09: CORRECTED PART TOTALS/ 4200008// 2000-2001; MARKET LAND VALUES UPDATED//04-05: stf approved 05-06: RECALC SETUP;#10 4/29/04 // 4200008 03-04: EXPIRATION OF STO PROGRAM. CONVERSION BY DOR TO DESIG FORESTLAND @ 100% PROGRAM // 04-05 CHANGING STO LAND FROM >5000 TO DESIGNATED._ /04-05: stf approved

Improvements - Residence / Manufactured Structures

Bldg: 1 Code Area: 04580 Stat Class: 121 + Year Blt: 1923 Eff Year Blt: 1943 Sq.Ft: 1142 % Complete: 100
 Desc: One Story Only Dimensions: RMV: 123570
 Func Obsc: 100 Econ %: 100 Other %: 100 Exception: 0 Adjust: Adjust RMV: 0

Floors

Type	Class	Display Group	Floor Size	Beds	Baths	Yr Blt	Eff Yr Blt	Inventory	Exception
First Floor	2 +	Finished	1142	3	FB-1	1923	1943	KIT-, ROOF, FP, HVAC, BATH - 1	Y N
Carport Attached	2	Unfinished	400	0	0	1923	1923	ROOF	Y N

Accessories

Description	Class	Size SqFt	Eff Yr Blt	RMV	Quantity	Exception
ENCLOSED PORCH	2	240	1943	3900	1	Y N
PATIO	2	144	1923	436	1	Y N
YARD IMPROVEMENTS AVERAGE	2	1	1943	6143	1	Y N

Bldg: 7 Code Area: 04580 Stat Class: 148 Year Blt: 2022 Eff Year Blt: 2022 Sq.Ft: 0 % Complete: 50
 Desc: Res other improvements Dimensions: RMV: 54970
 Func Obsc: 100 Econ %: 100 Other %: 100 Exception: 54970 Adjust: Adjust RMV: 0

Floors

Type	Class	Display Group	Floor Size	Beds	Baths	Yr Blt	Eff Yr Blt	Inventory	Exception
Garage Oversized Detached	4	Finished	1080	0	FB-1	2022	2022	ROOF, BATH - 1	Y N

Accessories

Description	Class	Size SqFt	Eff Yr Blt	RMV	Quantity
No accessory data available					

905 2022/2022

+ 27 SOLAR PANELS 27x250 \$6750 EXEMPT 1/0

Improvements - Accessory Buildings

Bldg: 3 Code Area: 04580 Stat Class: 354 Year Blt: Eff Year Blt: Sq.Ft: 400 % Complete: 100
 Desc: Lean-to Light (LTL) Dimensions: 20x20 RMV: 2030
 Func Obsc: 100 Econ %: 100 Other %: 100 Exception: 0 Adjust: ~~0~~ Adjust RMV: 0

Floors

Type	Class	Display Group	Floor Size	Beds	Baths	Yr Blt	Eff Yr Blt	Inventory	Exception: Y N
Lean-to Light Duty	4	Finished	400	0	0	0	0		Exception: Y N

Accessories

Description	Class	Size SqFt	Eff Yr Blt	RMV	Quantity
No accessory data available					

Bldg: 4 Code Area: 04580 Stat Class: 353 Year Blt: 1988 Eff Year Blt: 1988 Sq.Ft: 3782 % Complete: 100
 Desc: Machine Shed (MS) Dimensions: 122x31 RMV: 11120
 Func Obsc: 100 Econ %: 100 Other %: 100 Exception: 0 Adjust: Adjust RMV: 0

Floors

Type	Class	Display Group	Floor Size	Beds	Baths	Yr Blt	Eff Yr Blt	Inventory	Exception: Y N
Machine Shed	4	Finished	3782	0	0	1988	1988		Exception: Y N

Accessories

Description	Class	Size SqFt	Eff Yr Blt	RMV	Quantity
No accessory data available					

Bldg: 5 Code Area: 04580 Stat Class: 341 Year Blt: 1978 Eff Year Blt: 1978 Sq.Ft: 140 % Complete: 100
 Desc: Multi Purpose Shed (MP) Dimensions: 14x10 RMV: 880
 Func Obsc: 100 Econ %: 100 Other %: 100 Exception: 0 Adjust: Adjust RMV: 0

Floors

Type	Class	Display Group	Floor Size	Beds	Baths	Yr Blt	Eff Yr Blt	Inventory	Exception: Y N
Multi-Purpose Bldg	4	Finished	140	0	0	1978	1978	FAIR	Exception: Y N

Accessories

Description	Class	Size SqFt	Eff Yr Blt	RMV	Quantity
No accessory data available					

Bldg: 6 Code Area: 04580 Stat Class: 341 Year Blt: 1984 Eff Year Blt: 1984 Sq.Ft: 288 % Complete: 100
 Desc: Multi Purpose Shed (MP) Dimensions: 12x24 RMV: 1100
 Func Obsc: 100 Econ %: 100 Other %: 100 Exception: 0 Adjust: Adjust RMV: 0

Floors

Type	Class	Display Group	Floor Size	Beds	Baths	Yr Blt	Eff Yr Blt	Inventory	Exception: Y N
Multi-Purpose Bldg	4	Finished	288	0	0	1984	1984		Exception: Y N

Accessories

Description	Class	Size SqFt	Eff Yr Blt	RMV	Quantity
No accessory data available					

Bldg: 8 Code Area: 04580 Stat Class: 355 Year Blt: 2022 Eff Year Blt: 2022 Sq.Ft: 360 % Complete: 100
 Desc: Lean-to Heavy (LTH) Dimensions: 30x12 RMV: 3570
 Func Obsc: 100 Econ %: 100 Other %: 100 Exception: 3570 Adjust: Adjust RMV: 0

Floors

Type	Class	Display Group	Floor Size	Beds	Baths	Yr Blt	Eff Yr Blt	Inventory	Exception: Y N
Lean-to Heavy Duty	4	Finished	360	0	0	2022	2022	FAIR	Exception: Y N

Accessories

Description	Class	Size SqFt	Eff Yr Blt	RMV	Quantity
No accessory data available					

Handwritten blue scribble

Handwritten blue scribble

Handwritten blue scribbles: + CD A 360

Large blue scribbles covering the accessories table area

SKETCH/AREA TABLE ADDENDUM

SUBJECT INFO

File No.: 539627 Parcel No.: 081E05 00100
 Property Address: 1601 DRIFT CREEK ROAD S
 City: SUBLIMITY County: MARION State: OR ZipCode: 97385
 Owner:
 Client: Client Address:
 Appraiser Name: Inspection Date:

SKETCH

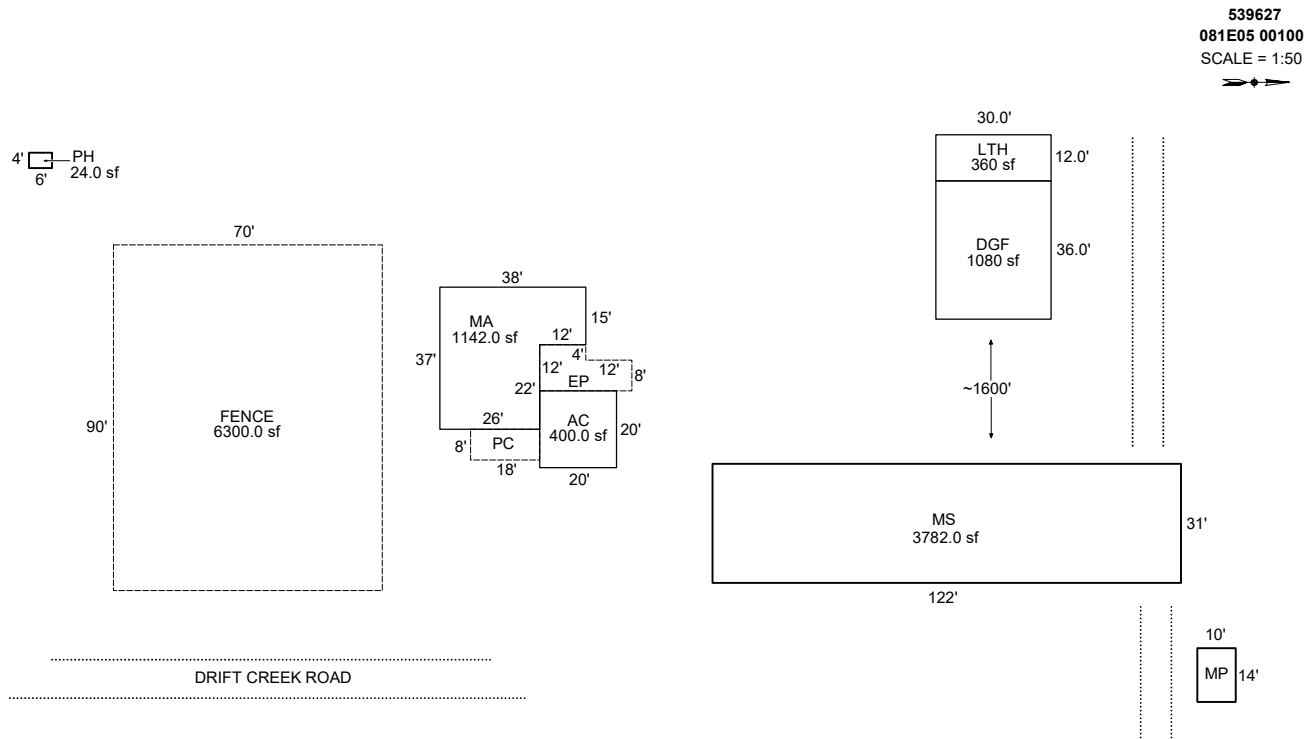

Sketch by Apex Sketch

AREA CALCULATIONS SUMMARY						COMMENT TABLE 1	
Code	Description	Factor	Net Size	Perimeter	Net Totals		
GBA1	PH	1.0	24.0	20.0		Apex 8/18/2011 Jane UPDATED BY CJURAN 01/23/2023 UPDATED BY CJURAN	
	MS	1.0	3782.0	306.0			
	MP	1.0	140.0	48.0			
	LTH	1.0	360.0	84.0	4306.0		
GLA1	MA	1.0	1142.0	150.0	1142.0		
GAR	AC	1.0	400.0	80.0			
	DGF	1.0	1080.0	132.0	1480.0		
P/P	EP	1.0	240.0	72.0			
	FENCE	1.0	6300.0	320.0			
	PC	1.0	144.0	52.0	6684.0		
	Net LIVABLE	cnt	1	(rounded)	1,142		
	Net BUILDING	cnt	4	(rounded)	4,306		
						COMMENT TABLE 2	COMMENT TABLE 3
						#10 CL 01/04/2023 CL 09/21/2023	TAGS L2 TAGS L2



9/21/23



DG/LTL 9/21/23



9/21/23