

Acct ID: 563451 MTL: 082W23C000800 Date: 1/2/24 Appr: MAL Prop Class: 541 RMV Prop Class: 401  
 Situs: 7563 TOMS WAY SE SALEM OR 97317 MaSaNh: 07 06 000 Unit: 117768 Year: ~~2023~~ 2024  
 Last Date Appraised: 02/09/2023 Appraiser: MATT LORD Retag: 0 N Tag info: 2024 - Tags/Permit (Completion)  
 Owner: HALL, PETER Roll Type: R  
 Cycle Tag Sales Verification Other: \_\_\_\_\_ Inspection level: 1 2 3 4 LCB TTO INSP AV: 325972  
 RMV Land: 192610 RMV Imp: 395050 RMV Total: 587660 MAV: 220580 MSAV: 842 SAV: 1301  
 Comment: 23-24: L2 2.9.23 CL

Can't find photo or last yrs from client.

**Notations**

House Addition @ 85% complete

RP/MS	Code	Description
RP	411	SEE ACCOUNT NOTES - 411
RP	FUZ	FARM NON-EFU ZONED

**OSDs**

Count	Code	Description	RMV	Code Area	Exception
1	MKTA	OSD - AVERAGE	45000	05558	0

**Land**

Site: 1	Code Area: 05558	Size: 1.00 Acres	Use Code: 004	Zone: NREST	SAV Use:	Exception: 0
Class: 4HD	Value Source: Market Homesite	Description: FOUR HILL DRY	RMV: 72360	Exception: Y	N	
Adjustment(s):		Fire Patrol:	Description:			
Comments: 560050: 02-03: CHANGED LAND TABLE FROM 00HA TO 00G BECAUSE THIS ACCT HAS IMPROVEMENTS / 02-03: REAPP //04-05: LAND SCHEDULE CHGS FOR RECALCULATION BY #29 //05-06: EDIT LISTS - REMOVE HOMESITE AND INCREMENT						
Site: 2	Code Area: 05558	Size: 1.04 Acres	Use Code: 004	Zone: NREST	SAV Use: 011	Exception: 0
Class: 4HD	Value Source: Farm Use - Non EFU	Description: FOUR HILL DRY	RMV: 75250	Exception: Y	N	
Adjustment(s):		Fire Patrol:	Description:			
Comments: Liability year - 1977 / 01-02: PER GI QUESTIONNAIRE, LAND IS IRRIG /02-03; CHANGED LAND SCHEDULE FROM 00HA TO 00GI TO REFLECT IMPROVEMENTS W/VALUE ON THE ACCOUNT //04-05: LAND SCHEDULE CHGS FOR RECALCULATION BY #29_ 05-06: F04-0907 LLA BETWEEN R63451 & R63453, IMPS NOT MOVING.						

**Improvements - Residence / Manufactured Structures**

Bldg: 2	Code Area: 05558	Stat Class: 108	Year Blt: 1990	Eff Year Blt: 1990	Sq.Ft: 0	% Complete: 100
Desc: Residential Other Improvements			Dimensions:	RMV: 4840		
Func Obsc: 100	Econ %: 100	Other %: 100	Exception: 0	Adjust:	Adjust RMV: 0	

**Floors**

Type	Class	Display Group	Floor Size	Beds	Baths	Yr Blt	Eff Yr Blt	Inventory
------	-------	---------------	------------	------	-------	--------	------------	-----------

No floor data available

**Accessories**

Description	Class	Size SqFt	Eff Yr Blt	RMV	Quantity
ASPHALT DRIVEWAY	1	1536	1990	3871	1
Exception: Y N					

Bldg: 3	Code Area: 05558	Stat Class: 108	Year Blt: 1971	Eff Year Blt: 1971	Sq.Ft: 0	% Complete: 100
Desc: Residential Other Improvements			Dimensions:	RMV: 610		
Func Obsc: 100	Econ %: 100	Other %: 100	Exception: 0	Adjust:	Adjust RMV: 0	

**Floors**

Type	Class	Display Group	Floor Size	Beds	Baths	Yr Blt	Eff Yr Blt	Inventory
------	-------	---------------	------------	------	-------	--------	------------	-----------

No floor data available

**Accessories**

Description	Class	Size SqFt	Eff Yr Blt	RMV	Quantity
CONCRETE DRIVEWAY	1	200	1971	488	1
Exception: Y N					

Bldg: 4	Code Area: 05558	Stat Class: 143 -	Year Blt: 1971	Eff Year Blt: 1971	Sq.Ft: 3228	% Complete: 100
Desc: One Story with basement			Dimensions:	RMV: 374680		
Func Obsc: 100	Econ %: 100	Other %: 100	Exception: 102570	Adjust:	Adjust RMV: 0	

**Floors**

Type	Class	Display Group	Floor Size	Beds	Baths	Yr Blt	Eff Yr Blt	Inventory	Exception: Y N
First Floor	4 -	Finished	1284	2	FB-1	1971	1971	HVAC, ROOF, FP, KIT-, BATH - 1	Exception: Y N
First Floor	4 -	Finished	798	0	0	1971	1971	85% Interior work	Exception: <u>Y</u> N
Second Floor	4 -	Finished	1146	0	0	1971	1971	HVAC	Exception: Y N
Basement	4 -	Unfinished	504	0	0	1971	1971	HVAC	Exception: Y N
Garage Attached	4	Finished	528	0	0	1971	1971	ROOF	Exception: Y N
Garage Attached	4	Finished	338	0	0	1971	1971	100%	Exception: <u>Y</u> N

**Accessories**

Description	Class	Size SqFt	Eff Yr Blt	RMV	Quantity	Exception: Y N
YARD IMPROVEMENTS FAIR	4	1	1971	12758	1	Exception: Y N

**Improvements - Accessory Buildings**

Bldg: 1	Code Area: 05558	Stat Class: 351	Year Blt: 1993	Eff Year Blt: 1993	Sq.Ft: 1200	% Complete: 100
Desc: General Purpose Building (GB)			Dimensions: 40x30		RMV: 12940	
Func Obsc: 100	Econ %: 100	Other %: 100	Exception: 0	Adjust:	Adjust RMV: 0	

**Floors**

Type	Class	Display Group	Floor Size	Beds	Baths	Yr Blt	Eff Yr Blt	Inventory	Exception: Y N
General Purpose Bldg	5	Finished	1200	0	0	1993	1993	FAIR	Exception: Y N

**Accessories**

Description	Class	Size SqFt	Eff Yr Blt	RMV	Quantity
No accessory data available					

Bldg: 5	Code Area: 05558	Stat Class: 354	Year Blt: 2022	Eff Year Blt: 2022	Sq.Ft: 400	% Complete: 100
Desc: Lean-to Light (LTL)			Dimensions: 20x20		RMV: 1980	
Func Obsc: 100	Econ %: 100	Other %: 100	Exception: 1980	Adjust:	Adjust RMV: 0	

**Floors**

Type	Class	Display Group	Floor Size	Beds	Baths	Yr Blt	Eff Yr Blt	Inventory	Exception: Y N
Lean-to Light Duty	4	Finished	400	0	0	2022	2022		Exception: Y N

**Accessories**

Description	Class	Size SqFt	Eff Yr Blt	RMV	Quantity
No accessory data available					

# SKETCH/AREA TABLE ADDENDUM

## SUBJECT INFO

File No.: 563451 Parcel No.: 082W23C 00800  
 Property Address: 7563 TOMS WAY SE  
 City: SALEM County: MARION State: OR ZipCode: 97317  
 Owner:  
 Client: Client Address:  
 Appraiser Name: Inspection Date:

## SKETCH

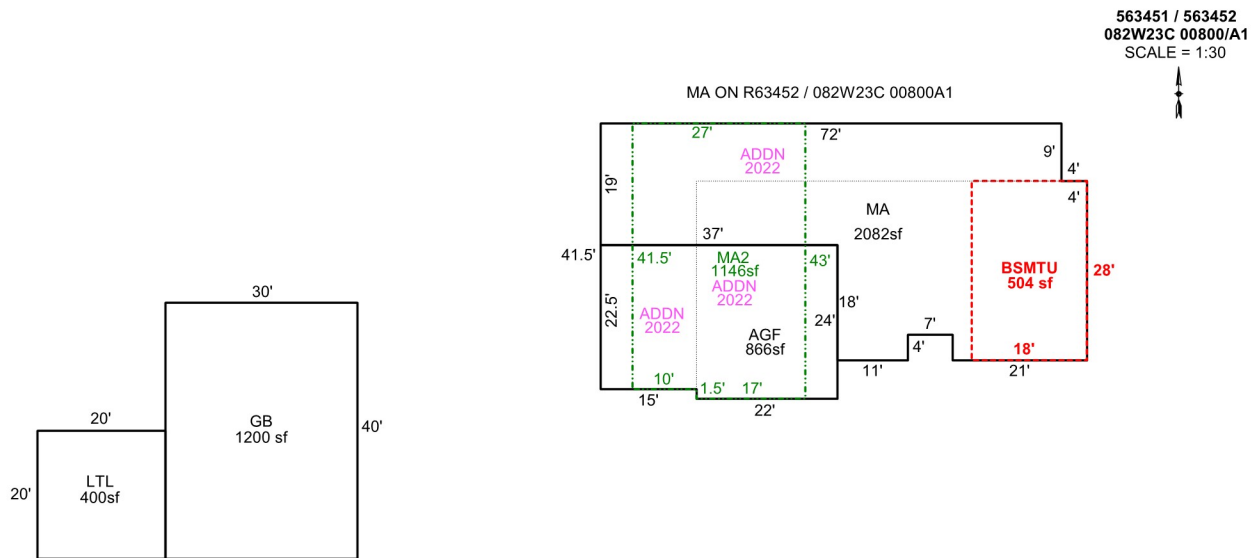

Sketch by Apex Sketch

### AREA CALCULATIONS SUMMARY

Code	Description	Factor	Net Size	Perimeter	Net Totals
GBA1	GB	1.0	1200.0	140.0	
	LTL	1.0	400.0	80.0	1600.0
GLA1	MA	1.0	2082.0	234.0	2082.0
GLA2	MA2	1.0	1146.0	140.0	1146.0
BSMT	BSMTU	1.0	504.0	92.0	504.0
GAR	AGF	1.0	865.5	122.0	865.5

### COMMENT TABLE 1

DRAWN BY JRONDEMA 3/14/18  
 UPDATED BY CJURAN 09/19/2022 555-22-003591  
 UPDATED BY CJURAN 02/23/2023

### COMMENT TABLE 2

CL 02/09/2023

### COMMENT TABLE 3

TAGS L2

Net LIVABLE	cnt	2	(rounded)	3,228
Net BUILDING	cnt	2	(rounded)	1,600

# SKETCH/AREA TABLE ADDENDUM

## SUBJECT INFO

File No.: 563451 Parcel No.: 082W23C 00800  
 Property Address: 7563 TOMS WY SE  
 City: SALEM County: MARION State: OR ZipCode: 97317  
 Owner:  
 Client: Client Address:  
 Appraiser Name: Inspection Date:

## SKETCH

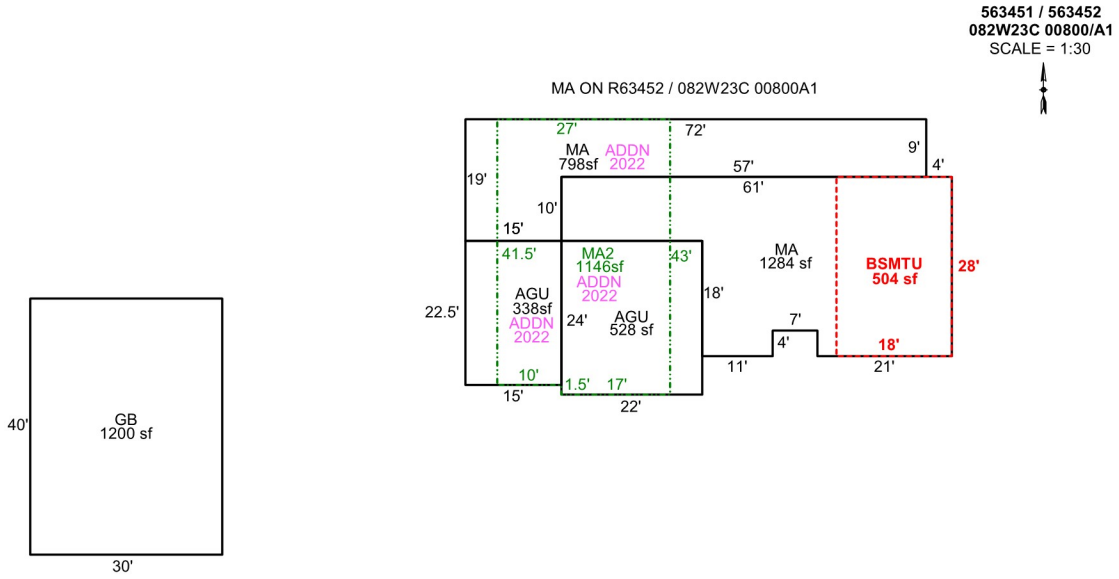

Sketch by Apex Sketch

### AREA CALCULATIONS SUMMARY

Code	Description	Factor	Net Size	Perimeter	Net Totals
GBA1	GB	1.0	1200.0	140.0	1200.0
GLA1	MA	1.0	1284.0	186.0	
	MA	1.0	798.0	182.0	2082.0
GLA2	MA2	1.0	1146.0	140.0	1146.0
BSMT	BSMTU	1.0	504.0	92.0	504.0
GAR	AGU	1.0	528.0	92.0	
	AGU	1.0	337.5	75.0	865.5

### COMMENT TABLE 1

DRAWN BY JRONDEMA 3/14/18  
 UPDATED BY CJURAN 09/19/2022 555-22-003591

### COMMENT TABLE 2

### COMMENT TABLE 3

Net LIVABLE cnt 3 (rounded) 3,228  
 Net BUILDING cnt 1 (rounded) 1,200

