

Acct ID: 561593 MTL: 083W27C001200 Date: 10.31.23 Appr: WW Prop Class: 641 RMV Prop Class: ~~641~~ **451**  
 Situs: 558 PHOENIX AVE SE SALEM OR 97306 MaSaNh: 06 06 000 Unit: 121321 Year: 2023

Last Date Appraised: 12/06/2022 Appraiser: WENDY WILLIAMS Retag: Y N Tag info: 2024 - Tags/Permit (Completion)  
 23-24: Per GRH addn to res @ 70%/cwo/ 22-002409  
 Owner: FOX, TAYLOR D Roll Type: R  
 Cycle: Tag Sales Verification Other: \_\_\_\_\_ Inspection level: 1 2 3 4 LCB TTO INSP AV: 189149  
 RMV Land: 289420 RMV Imp: 450280 RMV Total: 739700 MAV: 132050 MSAV: 2019 SAV: 3644

Comment: 23-24: L2 12.06.22 GRH  
 3/4/22 L4 GRH  
 update INR ADDN @ 100% INPUT WW 11/16/23

**Notations**

RP/MS	Code	Description
RP	DFL	DESIGNATED FORESTLAND

Forest OK

**OSDs**

Count	Code	Description	RMV	Code Area	Exception
1	MKTA	OSD - AVERAGE	40000	92430	0

**Land** Chris 12/7/23 Amy 12-29-23

Site: 1	Code Area: 92430	Size: 1.00 Acres	Use Code: 005	Zone: REST	SAV Use:	Exception: 0
Class: 4HD	Value Source: Market Homesite	Description: FOUR HILL DRY	RMV: 52620	Exception: Y	N	
Adjustment(s):	Fire Patrol:	Description:				
Comments: 2400230/00-01; SEPERATED INCREMENT FROM HOMESITE; 01-02: reapp						
Site: 2	Code Area: 92430	Size: 3.74 Acres	Use Code: 005	Zone: REST	SAV Use: 011	Exception: 0
Class: FTLC	Value Source: Designated Forest Land	Description: H&B or DFL Class C	RMV: 196800	Exception: Y	N	
Adjustment(s):	Fire Patrol:	Description:				
Comments: Liability year - 1984						

**Improvements - Residence / Manufactured Structures**

Bldg: 1	Code Area: 92430	Stat Class: 142	Year Blt: 1904	Eff Year Blt: <del>1980</del> 1992	Sq.Ft: 2614	% Complete: 100
Desc: Multi Story above grade	Dimensions:	RMV: 335730				
Func Obsc: 100	Econ %: 100	Other %: 100	Exception: 55080	Adjust:	Adjust RMV: 0	

**Floors**

Type	Class	Display Group	Floor Size	Beds	Baths	Yr Blt	Eff Yr Blt	Inventory	Exception
First Floor	4	Finished	1232	2	FB-3 HB-1	1904	1980	BTH - 1, HVAC+, ROOF, KIT+, BATH - 2	Y N
First Floor	4	Finished	710	0	0	1904	1980		Y N
Attic	4	Finished	672	2	FB-1	1901	1980	BATH 1 HB 1	Y N

**Accessories**

Description	Class	Size SqFt	Eff Yr Blt	RMV	Quantity	Exception
YARD IMPROVEMENTS AVERAGE	4	0	1980	22397	1	Y N

**Improvements - Accessory Buildings**

Bldg: 4	Code Area: 92430	Stat Class: 351	Year Blt: 2000	Eff Year Blt: 2000	Sq.Ft: 864	% Complete: 100
Desc: General Purpose Building (GB)	Dimensions: 24x36	RMV: 16650				
Func Obsc: 100	Econ %: 100	Other %: 100	Exception: 0	Adjust:	Adjust RMV: 0	

**Floors**

Type	Class	Display Group	Floor Size	Beds	Baths	Yr Blt	Eff Yr Blt	Inventory	Exception
General Purpose Bldg	6	Finished	864	0	0	2000	2000	FAIR	Y N

**Accessories**

Description	Class	Size SqFt	Eff Yr Blt	RMV	Quantity
No accessory data available					

**Improvements - Accessory Buildings**

Bldg: 5	Code Area: 92430	Stat Class: 351	Year Blt: 2010	Eff Year Blt: 2010	Sq.Ft: 2040	% Complete: 100
Desc: General Purpose Building (GB)	Dimensions: 24x33	RMV: 91070				
Func Obsc: 100	Econ %: 100	Other %: 100	Exception: 0	Adjust:	Adjust RMV: 0	

**Floors**

Type	Class	Display Group	Floor Size	Beds	Baths	Yr Blt	Eff Yr Blt	Inventory	Exception
General Purpose Bldg	4	Finished	792	0	0	2010	2010	FAIR	Y N
General Purpose Bldg	4	Finished	1248	0	0	2010	2010		Y N

**Accessories**

Description	Class	Size SqFt	Eff Yr Blt	RMV	Quantity	Exception: Y N
FINISHED OFFICE IN A FARM BUILDING	4	2040	2010	50949	0	

Bldg: 6    Code Area: 92430    Stat Class: 341    Year Blt: 2012    Eff Year Blt: 2012    Sq.Ft: 336    % Complete: 100  
 Desc: Multi Purpose Shed (MP)    Dimensions: 14x24    RMV: 6830  
 Func Obsc: 100    Econ %: 100    Other %: 100    Exception: 0    Adjust:    Adjust RMV: 0

*nc*

**Floors**

Type	Class	Display Group	Floor Size	Beds	Baths	Yr Blt	Eff Yr Blt	Inventory	Exception: Y N
Multi-Purpose Bldg	4	Finished	336	0	0	2012	2012	FAIR	

**Accessories**

Description	Class	Size SqFt	Eff Yr Blt	RMV	Quantity
No accessory data available					



# SKETCH/AREA TABLE ADDENDUM

## SUBJECT INFO

File No.: 561593 Parcel No.: 083W27C 01200  
 Property Address: 558 PHOENIX AV SE  
 City: SALEM County: MARION State: OR ZipCode: 97306  
 Owner:  
 Client: Client Address:  
 Appraiser Name: Inspection Date:

## SKETCH

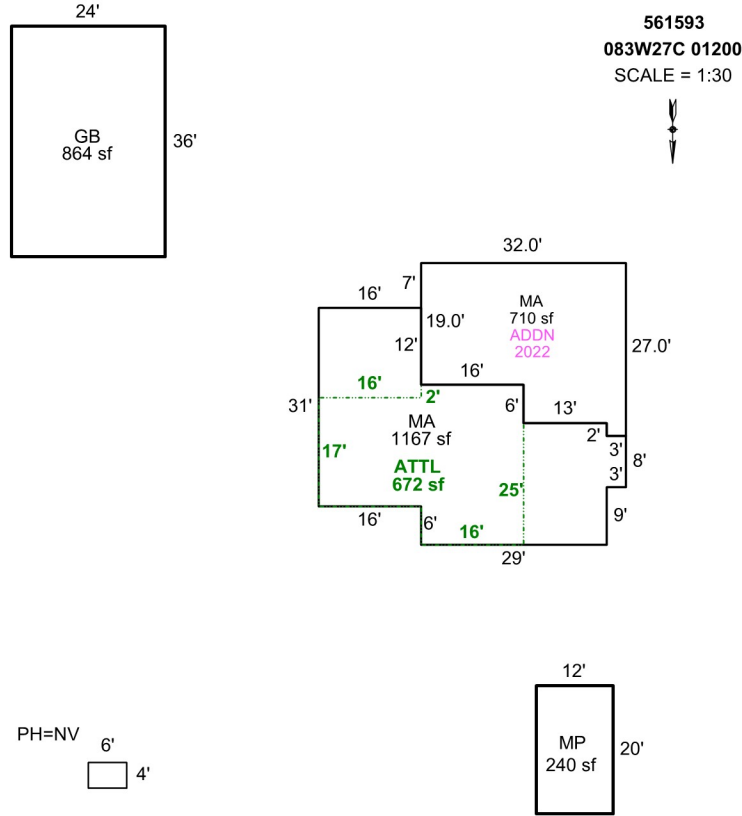

### AREA CALCULATIONS SUMMARY

Code	Description	Factor	Net Size	Perimeter	Net Totals
GBA1	GB	1.0	864.0	120.0	
	MP	1.0	240.0	64.0	1104.0
GLA1	MA	1.0	1167.0	170.0	
	MA	1.0	710.0	118.0	1877.0
GLA2	ATTL	1.0	672.0	114.0	672.0

### COMMENT TABLE 1

UPDATED BY CJURAN 03/09/2023

### COMMENT TABLE 2

GRH 12/06/2022

### COMMENT TABLE 3

TAGS L2

WW L1 tags 10.31.23

Net LIVABLE	cnt	3	(rounded)	2,549
Net BUILDING	cnt	2	(rounded)	1,104