

Summary

lak 10.25.24

GM 10-29-24

Lead Appr: _____ Clerk: _____ Lead Clerk: _____ Appr: _____

Print Date:

9/20/2024

Acct ID: 128148

MTL: 083W23DC05200P1

Date: 9-30-24

Appr: GM

Prop Class: 019

RMV Prop Class: 019

Situs: 2070 NAVAHO CT SE SALEM, OR 97306

MaSaNh: 16 05 003

Unit: 141315

Year: 2024

2025

Last Date Appraised: 10/07/2015

Appraiser: THERESA SWEARINGEN

Retag: Y N

Tag info:

Owner: BELSON, MARCELLA J

Roll Type: MS

Cycle Tag Sales Verification Other: _____

Inspection level: 1 2 3 4

LCB TTO INSP

NO MCS

AV: 39090

RMV Land: 0

RMV Imp: 61100

RMV Total: 61100

MAV: 39090

MSAV: 0

SAV: 0

Comment: SOUTHBROOK M.P., MS SERIAL # 64243CKPDFR13065, X # X00146138, PERSONAL MS

Update Heat

Notations

No notation data available.

OSDs

No OSD data available.

Land

No land data available.

Improvements - Residence / Manufactured Structures

No residence or manufactured structure improvement data available.

Improvements - Accessory Buildings

No improvement data available for all other stat class types.

MB



Improvement Detail

MARION County

For Assessment Year 2024

Account ID 128148

Map 083W23DC05200P1

Mailing BELSON, MARCELLA J
2070 NAVAHO CT SE
SALEM OR 97306

Situs 2070 NAVAHO CT SE SALEM OR 97306

Appraiser THERESA SWEARINGEN

Inspected 10/07/2015

Appraisal Area 16-05-003

Stat Class 466 - MANUF STRUCT, CLASS 6, 24' WIDE DOUBLE

Bldg	Code Area	Year Built	Eff Year	Comp %	% Good	LCM	Value	RMV	Taxable RMV	MAV	Exception	AV	Sqft
1	24010	1977	1977	100	20	231	Tabled	61,100	61,100	39,090	0	39,090	1,440

Rooms: 3 - BD, 2 - FB

Floor Segments

Description	Yr Blt	Eff Yr	% Good	Class	Comp %	OR %	Sqft	RCN
First Floor	1977	1977	20	6	100		1,440	130,388

Improvement Inventory

F	Description	Qty/Size	RMV	F	Description	Qty/Size	RMV
1st	ABOVE CLASS HEATING/COOLING HVAC	1,440	399	1st	ABOVE CLASS ROOF	1,440	0
1st	ABOVE CLASS KITCHEN	1	2,541	1st	AVERAGE CLASS SKIRTING	0	854
1st	BATH - FULL	2	1,386				

Accessories

Description	Eff Yr	Size	Qty	RMV
ROOF EXTENSION OR PATIO COVER	1977	275		1,595

Totals

Description	RMV
First Floor	\$31,257
Inventory	\$0
Accessories	\$1,595
Calculation	Tabled
Trend	186.00 %
Total RMV	\$61,100

Size Breakdown

Finished	1,440
----------	-------

Comments //2020-21 DELETE WL, INV. //16-17 CYCLE WORK INV UPDATE// 08-09 CYCLE WORK INVENTORY UPDATES PER #04// 01-02: REAPPRAISAL

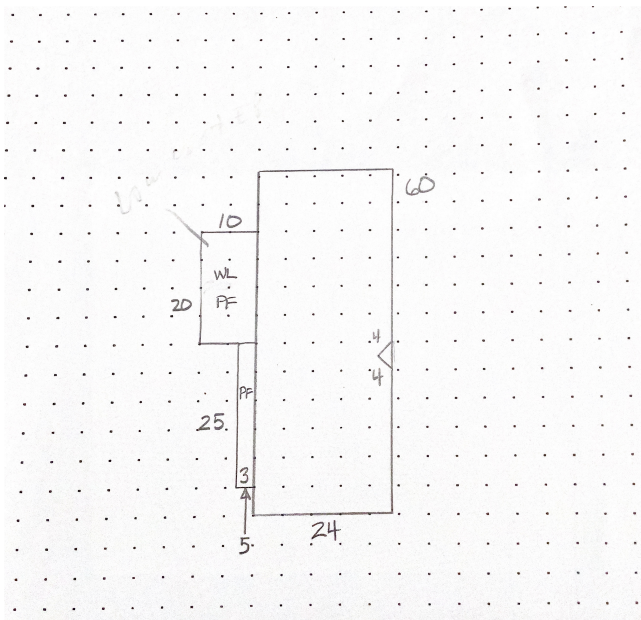

M128148 083W23DC05200 Appr #: DT4 Date 10-7-15 Prop Class 019 Prop Code T66 47
 Situs Address 2070 NAVAHO CT SE Franchise Code 04 Year For: 2015-2016
 Owner BELSON, GORDON J & 2016-17

Notes: Inventory update Tags Inventory update Cycle Inventory update Sales Verification Inventory update Other: GOLD

RMV Imp: 15,100 RMV Total: 15,100 M50 Total: 15,100

Seg.Type MA Seg. # 1.1 Method M04 Class 6D Area 1440 Eff Area 1440 Length 60 Width 24
 Make: GOLDENWEST Model: Intfinish: PANEL Roof Cover COMP ARCMP
 Plumbing BATH2 Heat: FA Fireplace: Inter. Comp: CKTP;OVEN-D;DW;DSP;H Bedrooms: 3
 Year Built 1977 Eff. Year Built 1977 Cond. P F A G E
 Adj Codes MSLCMD Qty 6 % Comp ___ Func ___ Econ ___ RMV 13,820
 Lump Sum ___ Except Code/Year ___ Comments orig.

Accessory Improvements

Seg.Type PF MFD STRUCT Seg. # 1.3 Method: R05 Class Area 275 Eff Area 275
 Length Width Foundation Ex. Wall Roof Cover FBRGL
 Roof Style Floor Plumbing
 Year Built 1977 Eff. Year Built: 1977 Cond. P F A G E % Comp ___ Econ ___ RMV: 1,080
 Lump Sum ___ Except Code/Year ___ Comments ___

Seg.Type WL MFD STRUCT Seg. # 1.4 Method: F;N Class Area 40 Eff Area 40
 Length Width Foundation Ex. Wall Roof Cover
 Roof Style Floor Plumbing
 Year Built Eff. Year Built: Cond. P F A G E % Comp ___ Econ ___ RMV: 0
 Lump Sum ___ Except Code/Year ___ Comments ___

Out Buildings and Skirting

Seg.Type MHSK MFD STRUCT Seg. # 1.2 Method: M04 Class Area 168 Eff Area 168
 Length Width Foundation Ex. Wall METAL Roof Cover



2070

2070



2070

10-02-15