

Summary

Lead Appr: _____ Clerk: _____ Lead Clerk: _____ Appr: **GM 10-29-24**

Print Date:

9/20/2024

Acct ID: 128022 MTL: 083W23DC05300P1 Date: 9-30-24 Appr: GM Prop Class: 019 RMV Prop Class: 019

Situs: 2020 NOMAD CT SE SALEM, OR 97306 MaSaNh: 16 05 003 Unit: 128022 Year: 2024

Last Date Appraised: 03/15/2022 Appraiser: THERESA SWEARINGEN Retag: Y N Tag info:

Owner: PIGNOTTI, RAYMOND Roll Type: MS

Cycle Tag Sales Verification Other: _____ Inspection level: 1 2 3 4 LCB TTO INSP 777573 AV: 36870

RMV Land: 0 RMV Imp: 87510 RMV Total: 87510 MAV: 36870 MSAV: 0 SAV: 0

Comment: 22-23: L2-3.15.22 TS

Update Heat

Notations

No notation data available.

OSDs

No OSD data available.

Land

No land data available.

Improvements - Residence / Manufactured Structures

Bldg: 1 Code Area: 24010 Stat Class: 456 + Year Blt: 1977 Eff Year Blt: 1993 Sq.Ft: 1440 % Complete: 100

Desc: MANUF STRUCT, CLASS 5, 24' WIDE DOUBLE Dimensions: RMV: 87510

Func Obsc: 100 Econ %: 100 Other %: 100 Exception: 0 Adjust: Adjust RMV: 0

Floors

Type	Class	Display Group	Floor Size	Beds	Baths	Yr Blt	Eff Yr Blt	Inventory	Exception: Y N
First Floor	5 +	Finished	1440	2	FB-2	1977	1993	BATH - 2, KIT+, <i>HVAC</i> , ROOF+, SKIRT	Y N

Accessories

Description	Class	Size SqFt	Eff Yr Blt	RMV	Quantity	Exception: Y N
ROOF EXTENSION OR PATIO COVER	5	437	1993	3802	0	Y N

Improvements - Accessory Buildings

No improvement data available for all other stat class types.



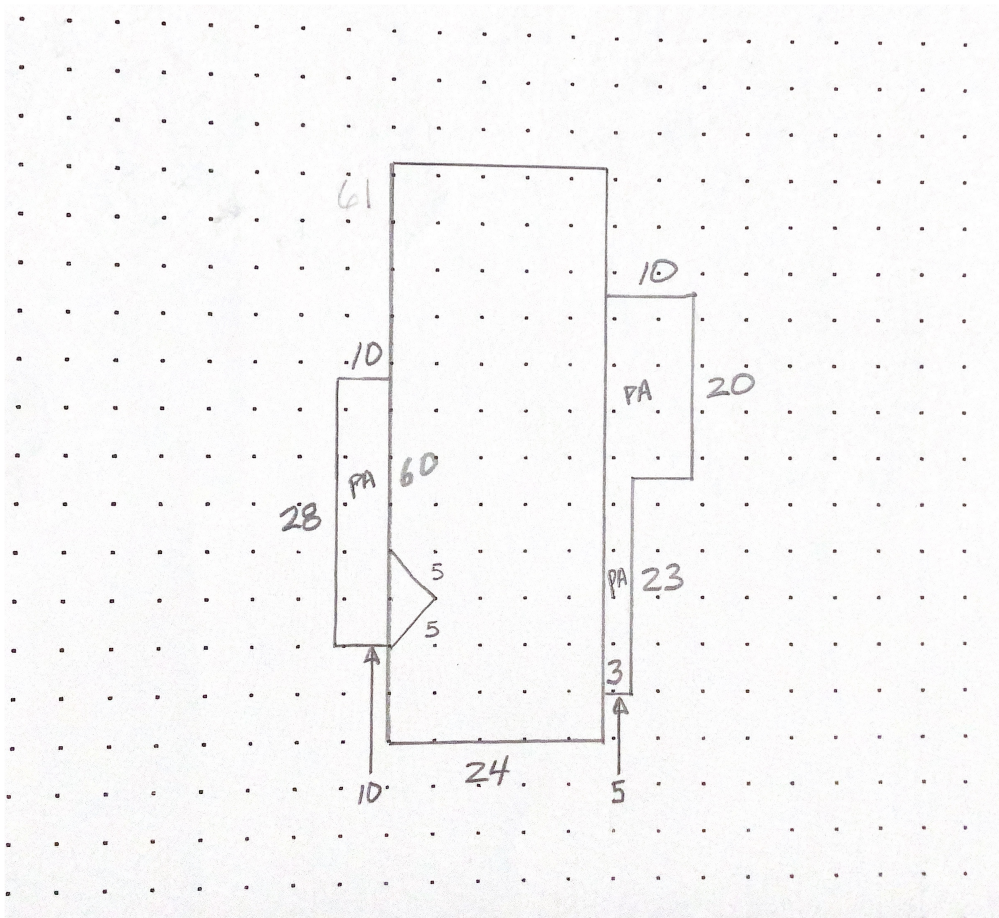

MUS Sold \$90,000 8/2021 (pics) will
maintained

LV2

MARION COUNTY ASSESSOR

Manufactured Structure Assessment Report

FOR ASSESSMENT YEAR 2022

NOT OFFICIAL VALUES

3/2/2022 1:18:03 PM

Account # 128022

Code - Tax # 24010

Mailing Address
 PIGNOTTI, RAYMOND
 PIGNOTTI, EVA
 2020 NOMAD CT SE
 SALEM OR 97306

TAX STATUS ASSESSABLE

ACCT STATUS ACTIVE

SUBTYPE PERSONAL

HOME ID 212688

X NUMBER X00143863

*M/S 777573
Pick ✓*

SITUS ADDRESS	SITUS CITY
2020 NOMAD CT SE	SALEM

APPRAISER THERESA SWEARINGEN

VALUE SUMMARY

CODE AREA	RMV	MAV	AV	TREND %	RMV EXCEPTION	CPR %
24010	IMPR.	\$18,030	\$34,760	\$18,030	100%	IMPR.

Manufactured Structure Information

VIN #	MB0357AB	STAT CLASS	456
BRAND	BROOKWOOD	QUALITY	100
MODEL	BENDIX	CONDITION	
YEAR BUILT	1977	MA / SA / NH	06 / 05 / 003
STICKER #		BEDROOMS / BATHS	2 / 1

Real Property Information

REAL ACCOUNT #	572016	MA / SA / NH	06 / 07 / 000
MAP	083W23DC05300	PROP CLASS	707
UNIT	135750	RMV CLASS	707
PARK NAME	SOUTHBROOK M.P.		
COMMENTS	LEVEL 2 LS89 090320//		

FLOORS

DESCRIPTION	CLASS	SQFT	SIZE TYPE	TYPE OF HEAT	RMV
First Floor	5	1,440	S		16,622

INVENTORY

	Size/Qty	RMV		Size/Qty	RMV
BATH - FULL	1	466	DISHWASHER	1	224
SKIRTING - METAL	170	146	DISPOSAL	1	59
FORCED AIR	1	0	HOOD & FAN	1	127
WOOD PANELING	1	0	SINGLE OVEN	1	93
COOKTOP	1	73	ROOF COVER - ARCHITECTURAL COMP	1	0
Total Inventory RMV					1188

ACCESSORIES

DESCRIPTION	EFF YEAR BUILT	SQFT	QUANTITY	RMV
ALUMINUM PATIO COVER	1971	437		1259
Total Accessories RMV				1259

EXEMPTIONS / SPECIAL ASSESSMENTS / POTENTIAL LIABILITY

TYPE

SPECIAL ASSESSMENT(S):

TYPE	MFD COMMUNITIES RES CTR	AMOUNT	\$10.00
-------------	-------------------------	---------------	---------

COMMENTS:

16-17 CYCLE WORK INV UPDATE SQ FT// 08-09 CYCLE WORK INVENTORY UPDATES PER #04// 01-02: REAPPRAISAL

Improvement Detail

MARION County

For Assessment Year 2022

Account ID 128022

083W23DC05300P1

Appraiser

THERESA SWEARINGEN

Inspected 10/07/2015

ing
PIGNOTTI, RAYMOND
PIGNOTTI, EVA
2020 NOMAD CT SE
SALEM OR 97306

Area

06-05-003

Stat Class

456 - MANUF STRUCT, CLASS 5, 24' WIDE DOUBLE

Situs 2020 NOMAD CT SE SALEM OR 97306

Bldg	Code	Year	Eff	Comp %	% Good	LCM	Value	RMV	Taxable	MAV	Exception	AV	Sqft
Rooms: 2 - BD,	1 - FB											18,	

Description	Floor Segments			Class	Comp %	OR %	Sqft	RCN
	Yr Blt	Eff Yr	% Good					
		1993					1	9

Improvement Inventory					
Description	Qty/Size	RMV	Description	Qty/Size	RMV
1st COOKTOP	1	73	1st ROOF COVER - ARCHITECTURAL COMP	1440	0
1st DISHWASHER	1	224	1st SINGLE OVEN	1	93
1st DISPOSAL	1	59	1st SKIRTING - METAL	170	146
1st FORCED AIR HP	1440	0	1st WOOD PANELING	1440	0

Accessories					
Description	Eff Yr	Size	Qty	RMV	
PATIO COVER	1993				

Description	Totals	RMV
Inventory		\$22
Accessories		\$146
Trend		100.00 %
Total RMV		\$18,030

Size Breakdown	
Finished	1,440

Comments T6-17 CYCLE WORK INV UPDATE SQ FT// 08-09 CYCLE WORK INVENTORY UPDATES PER #04// 01-02: REAPPRAISAL

Remove cond %
update Inv & EYB & class

Input mij

ts 5-26-22

3/2/2022

V. windows
0-sided

P. check
V. windows
O. Kit PAB
NEW Vm7s + skirting-master
B's
W.M.

MCS
w.m.
NEW HP's & other
Renov. master Bath

SALES INFORMATION	
SALES PRICE	\$90,000
EXEMPT AMOUNT	
FINAL PRICE	\$90,000
RMV	\$18,030
RATIO %	20
SALES DATE	13-Aug-2021
DOCUMENT	DCBS
CONDITION CODE	00
UNCONFIRMED	

OWNERSHIP INFORMATION			
GRANTOR NAME	MCDERMOTT, THERESA M &		
AGENT			
ADDRESS	2020 NOMAD CT SE		
CITY	SALEM		
STATE	OR	ZIP	97306
GRANTEE NAME	Pignotti, Raymond		
AGENT	Pignotti, Eva		
ADDRESS	2020 Nomad Ct SE		
CITY	SALEM		
STATE	OR	ZIP	97306

Verification Form

SALES CONFIRMATION	
CONFIRMATION DATE	
CONFIRMATION TYPE	

PRIMARY ACCOUNT INFORMATION			
PROPERTY CLASS	019	MA	06
RMV PROPERTY CLASS	019	SA	05
		NH	003

ACCOUNT INFORMATION							
ACCT ID	MAP	UNIT ID	PROP CLS	RMV CLS	MA	SA	NH
128022	083W23DC05300P1	128022	019	019	06	05	003
MNFACT STRUCT(S)		ACCT #	STAT	YR BLT	LIV AREA	BRAND	
2020 NOMAD CT SE SALEM OR 97306		128022	456	1977	1,440	BROOKWOOD	

TTO
MLS
777573

Sale Type: _____ Sale Price: _____ Sale Date: _____

Verified With: _____ (buyer/seller/other)

Phone# or Email: _____

- | | | |
|--|---------------|--|
| 1. Was the property listed on the open market? (MLS/FSBO/online/other) | <i>Bilbow</i> | Yes / No |
| 2. Was a realtor involved? | | <input checked="" type="checkbox"/> <input type="checkbox"/> |
| 3. Was the sale between related parties? (business/family/other) | | <input type="checkbox"/> <input checked="" type="checkbox"/> |
| 4. Did you shop around? How long? <i>couple months</i> | | <input type="checkbox"/> <input type="checkbox"/> |
| 5. Was there trade involved? Estimated value: _____ | | <input type="checkbox"/> <input checked="" type="checkbox"/> |
| 6. Was there any personal property, crops, livestock or timber included in the sale price? (car, boat, furniture, etc.) Estimated value: _____ | | <input type="checkbox"/> <input checked="" type="checkbox"/> |
| 7. Did you pay any back taxes? | | <input type="checkbox"/> <input checked="" type="checkbox"/> |
| 8. Did the seller pay any closing costs or any other concessions? \$ _____ | | <input type="checkbox"/> <input checked="" type="checkbox"/> |
| 9. Were you under any pressure to buy / sell the property? | | <input type="checkbox"/> <input checked="" type="checkbox"/> |
| 10. Do you feel the price paid was fair market value? | | <input checked="" type="checkbox"/> <input type="checkbox"/> |

11. Condition at sale: Poor Fair Average Good Excellent

Description of maintenance problems: _____

12. Amenities/Externalities affecting purchase, e.g. view, water, traffic, treed setting, easement, topography, shape, wasteland, etc.: Value \$ _____

13. Appraiser _____ Date _____ Have any improvements been made to the property since time of purchase?

Description: *new floor,*



2020

10/20/2017



10-02-15