

lak 10.25.24

GM 10-29-24

Summary

Lead Appr: _____ Clerk: _____ Lead Clerk: _____ Appr: _____

Print Date:

9/20/2024

Acct ID: 127554 MTL: 083W23DC05200P1 Date: 9-30-24 Appr: GM Prop Class: 019

RMV Prop Class: 019

Situs: 2050 NOMAD CT SE SALEM, OR 97306

MaSaNh: 16 05 003

Unit: 141086

Year: 2024

ms

Last Date Appraised: 10/07/2015 Appraiser: THERESA SWEARINGEN Retag: Y N Tag info:

Owner: DIMARTINO, JOHN J & DIMARTINO, BRENDA J

Roll Type: MS

Cycle 0 Tag Sales Verification Other: _____ Inspection level: 1 2 3 4 LCB TTO INSP *No ms*

AV: 19150

RMV Land: 0 RMV Imp: 44260 RMV Total: 44260 MAV: 19150 MSAV: 0

SAV: 0

Comment: SOUTHBROOK M.P., MS SERIAL # 70142CK03950469K, X # X00136499, PERSONAL MS

up late Heat

Notations

No notation data available.

OSDs

No OSD data available.

Land

No land data available.

Improvements - Residence / Manufactured Structures

No residence or manufactured structure improvement data available.

Improvements - Accessory Buildings

No improvement data available for all other stat class types.



Improvement Detail

MARION County
For Assessment Year 2024

Account ID 127554

Map 083W23DC05200P1

Mailing DIMARTINO, JOHN J & DIMARTINO, BRENDA J
2050 NOMAD CT SE
SALEM OR 97306

Situs 2050 NOMAD CT SE SALEM OR 97306

Appraiser THERESA SWEARINGEN

Inspected 10/07/2015

Appraisal Area 16-05-003

Stat Class 454 - MANUF STRUCT, CLASS 5, 14' WIDE SINGLE

Bldg	Code Area	Year Built	Eff Year	Comp %	% Good	LCM	Value	RMV	Taxable RMV	MAV	Exception	AV	Sqft
1	24010	1977	1979	100	20	231	Tabled	44,260	44,260	19,150	0	19,150	924

Rooms: 2 - BD, 2 - FB

Floor Segments

Description	Yr Blt	Eff Yr	% Good	Class	Comp %	OR %	Sqft	RCN
First Floor	1977	1979	20	5	100		924	85,193

Improvement Inventory

F	Description	Qty/Size	RMV	F	Description	Qty/Size	RMV
1st	ABOVE CLASS HEATING/COOLING HVAC	924	363	1st	AVERAGE CLASS SKIRTING	0	813
1st	AVERAGE CLASS ROOF	924	0	1st	BATH - FULL	2	1,386
1st	BELOW CLASS KITCHEN	1	647				

Accessories

Description	Eff Yr	Size	Qty	RMV
ROOF EXTENSION OR PATIO COVER	1979	502		2,912
DECK	1979	144		634

Totals

Description	RMV
First Floor	\$20,247
Inventory	\$0
Accessories	\$3,546
Calculation	Tabled
Trend	186.00 %
Total RMV	\$44,260

Size Breakdown

Finished 924

Comments 23-24: Mass below threshold MS accts were made inactive for 22-23. should have been made active after roll turn, REMOVING NOTIFICATION, "TO CANCEL ACCT ONCE TAXES HAVE BEEN PAID". mwiltse 5-8-23

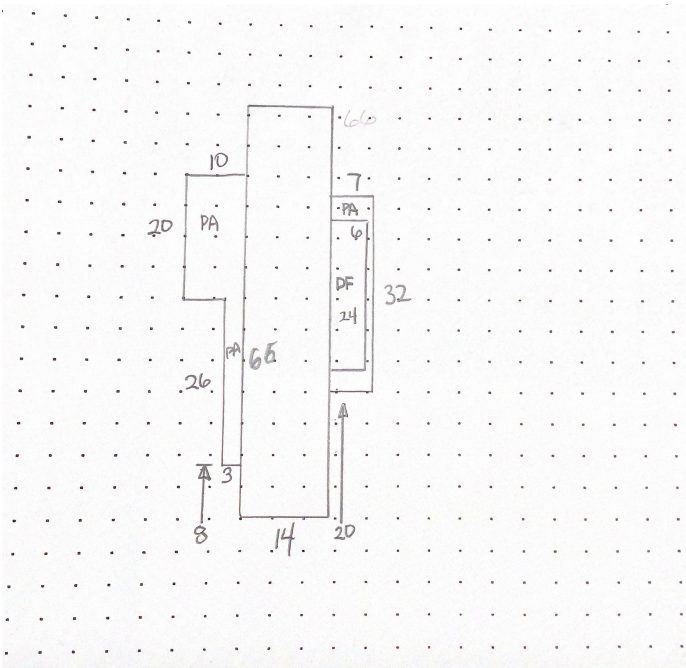

✓ M127554 083W23DC05200 Appr #: DT4 Date 10-7-15 Prop Class 019 Prop Code T54 28
 Situs Address 2050 NOMAD CT SE Franchise Code 04 Year For: 2015-2016
 Owner DIMARTINO, JOHN J & 2016-17
 Tags Cycle Sales Verification Other: Tral.
 Notes: RMV chg.

RMV Imp: 7,440 RMV Total: 7,440 M50 Total: 0

Seg.Type MA	Seg. # 1.1	Method M04	Class 5S	Area 924	Eff Area 924	Length 66	Width 14
Make: SKYLINE	Model: HOMETTE	Intfinish: PANEL	Roof Cover BLTUP				
Plumbing BATH2	Heat: FA	Fireplace:	Inter. Comp: H&F		Bedrooms: 2		
Year Built 1977	Eff. Year Built 1979	Cond. P F <u>A</u> G E					
Adj Codes MSLCMS	Qty <u>5</u>	% Comp	Func	Econ	RMV 5,810		
Lump Sum	Except Code/Year	Comments <u>Vinyl Windows, Roof Skin</u>					

Accessory Improvements

Seg.Type PA	MFD STRUCT	Seg. # 1.3	Method: R05	Class	Area 502	Eff Area 502
Length	Width	Foundation	Ex. Wall		Roof Cover METAL	
Roof Style	Floor		Plumbing			
Year Built 1977	Eff. Year Built: 1977	Cond. P F A G E		% Comp	Econ	RMV: 1,170
Lump Sum	Except Code/Year	Comments				

Seg.Type DF	MFD STRUCT	Seg. # 1.4	Method: R05	Class	Area 144	Eff Area 144
Length 24	Width 6	Foundation	Ex. Wall		Roof Cover	
Roof Style	Floor		Plumbing			
Year Built 1977	Eff. Year Built: 1977	Cond. P F A G E		% Comp	Econ	RMV: 220
Lump Sum	Except Code/Year	Comments				

Out Buildings and Skirting

Seg.Type MHSK	MFD STRUCT	Seg. # 1.2	Method: M04	Class	Area 160	Eff Area 160
Length	Width	Foundation	Ex. Wall WOOD		Roof Cover	





10-02-15