

Acct ID: 519930 MTL: 063W24A002000 Date: **6/14/24** Appr: **GRH** Prop Class: 451 RMV Prop Class: 451
 Situs: 8355 RIVER RD NE SALEM OR 97303 MaSaNh: 04 06 002 Unit: 59550 Year: 2024

Last Date Appraised: 07/26/2019 Appraiser: GERARDO RAMIREZ HERNANDEZ Retag: Y N Tag info:

Owner: LLAMAS, SOTERO & LLAMAS, ROSA E GARCIA Roll Type: R
 Cycle Tag Sales Verification Other: _____ Inspection level: 1 2 3 4 LCB TTO INSP AV: 255180
 RMV Land: 181160 RMV Imp: 263070 RMV Total: 444230 MAV: 255180 MSAV: 0 SAV: 0
 Comment:

Update inv

Notations
 No notation data available.

OSDs

Count	Code	Description	RMV	Code Area	Exception
1	MKTA	OSD - AVERAGE	45000	01410	0

Land

Site: 1 Code Area: 01410 Size: 0.91 Acres Use Code: 005 Zone: REST SAV Use: Exception: 0
 Class: Value Source: Rural Restrictive Description: **2BD** RMV: 136160 Exception: Y N
 Adjustment(s): **GSOIL** Fire Patrol: Description:
 Comments: 06-07: RECALC SETUP, APPR NO 19, 10/19/05

Improvements - Residence / Manufactured Structures

Bldg: 1 Code Area: 01410 Stat Class: 141 Year Blt: 1956 Eff Year Blt: 1985 Sq.Ft: 1883 % Complete: 100
 Desc: One Story Only Dimensions: RMV: 246720 **I/O**
 Func Obsc: 100 Econ %: 100 Other %: 100 Exception: 0 Adjust: Adjust RMV: 0

Floors

Type	Class	Display Group	Floor Size	Beds	Baths	Yr Blt	Eff Yr Blt	Inventory	Exception
First Floor	4	Finished	1883	4	FB-2	1956	1985	BATH - 2, KIT-, HVAC, FP - 1, ROOF	Y N
Garage Attached	4	Low Cost	447	0	0	1970	1985	ROOF	Y N

Accessories

YI 4 Fair AVRG

Description	Class	Size SqFt	Eff Yr Blt	RMV	Quantity	Exception
CONCRETE DRIVEWAY	4	500	1956	1121	1	Y N
PATIO	4	90	1985	401	1	Y N
PATIO	4	432	1985	1925	1	Y N
ROOF EXTENSION OR PATIO COVER	4	90	1956	1801	1	Y N

Bldg: 2 Code Area: 01410 Stat Class: 108 Year Blt: 1970 Eff Year Blt: 1970 Sq.Ft: 0 % Complete: 100
 Desc: Residential Other Improvements Dimensions: RMV: 2660
 Func Obsc: 100 Econ %: 100 Other %: 100 Exception: 0 Adjust: Adjust RMV: 0

Floors

Type	Class	Display Group	Floor Size	Beds	Baths	Yr Blt	Eff Yr Blt	Inventory	Exception
No floor data available									

Accessories

Delete, part of YI

Description	Class	Size SqFt	Eff Yr Blt	RMV	Quantity	Exception
ASPHALT DRIVEWAY	1	1200	1970	2664	1	Y N

Improvements - Accessory Buildings

Bldg: 3 Code Area: 01410 Stat Class: 351 Year Blt: 2003 Eff Year Blt: 2003 Sq.Ft: 1080 % Complete: 100
 Desc: General Purpose Building (GB) Dimensions: 36x30 RMV: 11400
 Func Obsc: 100 Econ %: 100 Other %: 100 Exception: 0 Adjust: Adjust RMV: 0

Floors

Type	Class	Display Group	Floor Size	Beds	Baths	Yr Blt	Eff Yr Blt	Inventory	Exception
General Purpose Bldg	4		1080	0	0	2003	2003	FAIR	Y N

Accessories

Description	Class	Size SqFt	Eff Yr Blt	RMV	Quantity	Exception
CONCRETE DRIVEWAY	4	250	2003	825	1	Y N
PATIO	4	200	2003	660	1	Y N

Bldg: 4 Code Area: 01410 Stat Class: 341 Year Blt: 1974 Eff Year Blt: 1988 Sq.Ft: 280 % Complete: 100

Desc: Multi Purpose Shed (MP)

Dimensions: 28x10

RMV: 1480

Func Obsc: 100

Econ %: 100

Other %: 100

Exception: 0

Adjust:

Adjust RMV: 0

I/O

Floors

Type	Class	Display Group	Floor Size	Beds	Baths	Yr Blt	Eff Yr Blt	Inventory	Exception: Y N
Multi-Purpose Bldg	4	Finished	280	0	0	1974	1988	Fair	

Accessories

Description	Class	Size SqFt	Eff Yr Blt	RMV	Quantity
No accessory data available					

Bldg: 5 Code Area: 01410 Stat Class: 341 Year Blt: Eff Year Blt: Sq.Ft: 96 % Complete: 100

Desc: Multi Purpose Shed (MP)

Dimensions: 8x12

RMV: 0

Func Obsc: 100

Econ %: 100

Other %: 100

Exception: 0

Adjust:

Adjust RMV: 0

Floors

Type	Class	Display Group	Floor Size	Beds	Baths	Yr Blt	Eff Yr Blt	Inventory	Exception: Y N
Multi-Purpose Bldg	4	Finished	96	0	0	0	0		

NI

Accessories

Description	Class	Size SqFt	Eff Yr Blt	RMV	Quantity
No accessory data available					

Bldg: 6 Code Area: 01410 Stat Class: 354 Year Blt: 2005 Eff Year Blt: 2005 Sq.Ft: 312 % Complete: 100

Desc: Lean-to Light (LTL)

Dimensions:

RMV: 810

Func Obsc: 100

Econ %: 100

Other %: 100

Exception: 0

Adjust:

Adjust RMV: 0

NIC

Floors

Type	Class	Display Group	Floor Size	Beds	Baths	Yr Blt	Eff Yr Blt	Inventory	Exception: Y N
Lean-to Light Duty	4	Finished	312	0	0	2005	2005		

Accessories

Description	Class	Size SqFt	Eff Yr Blt	RMV	Quantity
No accessory data available					

SKETCH/AREA TABLE ADDENDUM

Parcel No **063W24A 0200**

File No **R19930**

SUBJECT

Property Address **8355 RIVER RD N**

City **SALEM**

State **OR**

Zip **97303**

Owner

Client

Appraiser Name

IMPROVEMENTS SKETCH

APEX UPDATED

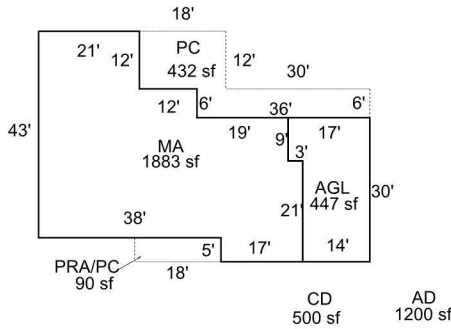
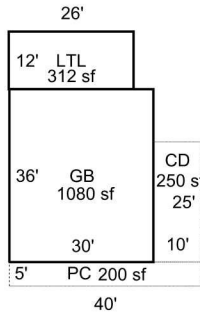
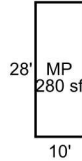

R19930
063W24A 0200
SCALE=1:40

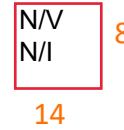

Scale: **1" = 40'**

AREA CALCULATIONS

AREA CALCULATIONS SUMMARY

Code	Description	Factor	Net Size	Perimeter	Net Totals
GLA1	MA	1.00	1883	206	1883
GBA1	GB	1.00	1080	132	
	LTL	1.00	312	76	
GAR	MP	1.00	280	76	1672
	AGL	1.00	447	94	447
YI1	PRA/PC	1.00	90	46	
	PC	1.00	432	132	
	CD	1.00	250	70	
	PC	1.00	200	90	972

Net LIVABLE Area (rounded w/ factors) **1883**
 Net BUILDING Area (rounded w/ factors) **1672**

Comment Table 1

DRAWN BY NC 11/25/2008
 UPD BY PH 01.31.20

Comment Table 2

07.26.19 CL #10

Comment Table 3

CYCLE