

# SKETCH/AREA TABLE ADDENDUM

## SUBJECT INFO

File No.: 105835 Parcel No.: 082W21CC02700  
 Property Address: 5530 APOLLO ST SE  
 City: TURNER County: State: OR ZipCode: 97392  
 Owner:  
 Client: Client Address:  
 Appraiser Name: Inspection Date:

## SKETCH

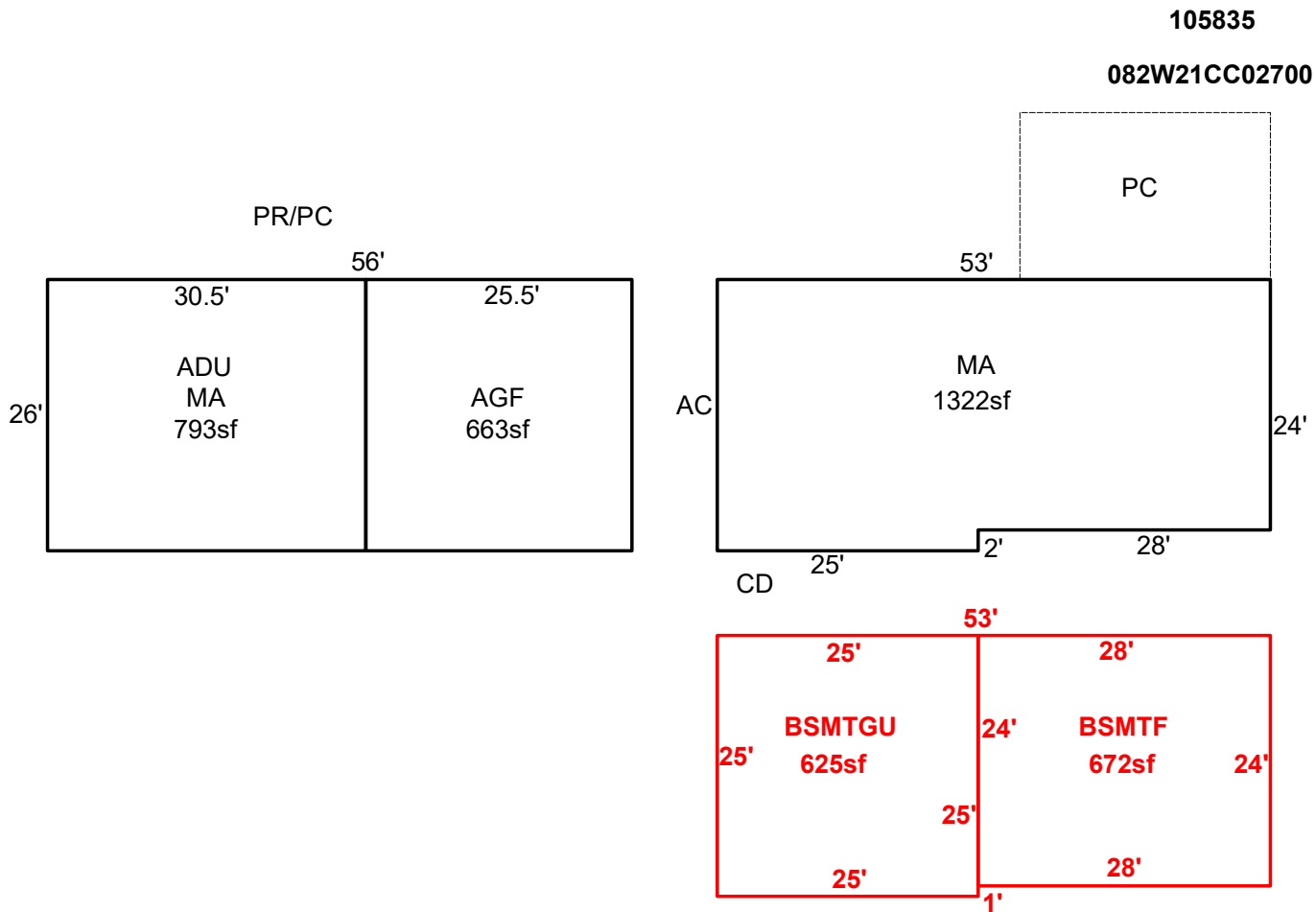

Sketch by ApexSketch

### AREA CALCULATIONS SUMMARY

Code	Description	Factor	Net Size	Perimeter	Net Totals
GLA	MA	1.0	793.0	113.0	793.0
GLA0	BSMTF	1.0	672.0	104.0	672.0
GLA1	MA	1.0	1322.0	158.0	1322.0
GAR	BSMTGU	1.0	625.0	100.0	
	AGF	1.0	663.0	103.0	1288.0
P/P	PC	1.0	384.0	80.0	384.0

### COMMENT TABLE 1

APEX BY TB 04-16-08  
 UPDATED BY JT 2/21/24  
 Updated by AE 9.4.24

### COMMENT TABLE 2

### COMMENT TABLE 3

Net LIVABLE                      cnt                      2      (rounded)                      2,787