

Summary

Lead Appr: _____ Clerk: Chris 10/20/23 Lead Clerk: _____ Appr: MDL

Acct ID: 355166 MTL: 081W350000503 Date: 6/16/23 Appr: MDL Prop Class: 551 RMV Prop Class: 551
Situs: 7987 BOEDIGHEIMER RD SE SUBLIMITY OR 97385 MaSaNh: 07 06 000 Unit: 37658 Year: 2023
Last Date Appraised: 01/27/2022 Appraiser: MATT LORD Retag: Y N Tag info: 2024 - NEW RESIDENCE (Completion)
Owner: ELWOOD, SANDI S Roll Type: R
Cycle Tag Sales Verification Other: Farm Check Inspection level: 1 2 3 4 LCB TTO INSP AV: 538141
RMV Land: 198130 RMV Imp: 699760 RMV Total: 897890 MAV: 227670 MSAV: 9111 SAV: 85629
Comment: 22-23 L2 1/27/22 ML

Notations

NO signs of horses ✓ 1/1/24 when we bring house to 100%

RP/MS	Code	Description
RP	411	SEE ACCOUNT NOTES - 411
RP	ZONED	FARM EFU ZONED

OSDs

Count	Code	Description	RMV	Code Area	Exception
1	SAF	SA OSD - FAIR	35000	29588	0

Land

Site: 1	Code Area: 29588	Size: 1.00 Acres	Use Code: 005	Zone: REST	SAV Use: 011	Exception: 0
Class: 2BD	Value Source: Farm Homesite	Description: TWO BENCH DRY	RMV: 78800	Exception: Y	N	
Adjustment(s): GSOIL	Fire Patrol: SA004	Description: FIRE PATROL				
Comments: Liability year - 2009 / 21-22: UPDATE PART TOTALS / 21-22: PER #103 CHG LAND SCH FOR WOODLOT / 19-20: MANUALLY ADJUST MSAV, XFER INCORRECTLY IN 18-19 FROM R29099						
Site: 3	Code Area: 29588	Size: 1.07 Acres	Use Code: 005	Zone: REST	SAV Use: 011	Exception: 0
Class: 2BD	Value Source: Farm Use - EFU	Description: TWO BENCH DRY	RMV: 84330	Exception: Y	N	
Adjustment(s): GSOIL	Fire Patrol: SA004	Description: FIRE PATROL				
Comments:						

Improvements - Residence / Manufactured Structures

Bldg: 1	Code Area: 29588	Stat Class: 144	Year Blt: 1947	Eff Year Blt: 1947	Sq.Ft: 2830	% Complete: 100
Desc: Multi Story above grade with basement			Dimensions:	RMV: 351820		
Func Obsc: 100	Econ %: 100	Other %: 100	Exception: 0	Adjust:	Adjust RMV: 0	

Floors

Type	Class	Display Group	Floor Size	Beds	Baths	Yr Blt	Eff Yr Blt	Inventory	Exception:
First Floor	4	Finished	2120	2	FB-2	1947	1947	BATH - 2, KIT+, ROOF, HVAC+, FP	Y N
Attic	4	Finished	710	2	0	1947	1947	HVAC	Y N
Basement	4	Unfinished	1640	0	FB-1	1947	1947	BATH - 1	Y N
Carport Attached	4	Unfinished	416	0	0	1947	1947	ROOF	Y N

Accessories

Description	Class	Size SqFt	Eff Yr Blt	RMV	Quantity	Exception:
ASPHALT DRIVEWAY	4	3870	1947	7663	1	Y N
DECK	4	440	1947	6389	1	Y N
PATIO	4	40	1947	145	1	Y N
PATIO	4	420	1947	1525	1	Y N
PATIO	4	430	1947	1561	1	Y N
ROOF EXTENSION OR PATIO COVER	4	40	1947	766	1	Y N

Bldg: 7	Code Area: 29588	Stat Class: 141	Year Blt: 2022	Eff Year Blt: 2022	Sq.Ft: 3306	% Complete: 55
Desc: One Story Only			Dimensions:	RMV: 301360		
Func Obsc: 100	Econ %: 100	Other %: 100	Exception: 301360	Adjust:	Adjust RMV: 0	

Floors

Type	Class	Display Group	Floor Size	Beds	Baths	Yr Blt	Eff Yr Blt	Inventory	Exception:
First Floor	4	Finished	3306	3	FB-2	2022	2022	BATH - 2, KIT-, BATH+, ROOF, HVAC+	Y N
Garage Attached	4	Finished	1444	0	0	2022	2022	ROOF	Y N

Accessories

Description	Class	Size SqFt	Eff Yr Blt	RMV	Quantity	Exception:
YARD IMPROVEMENTS AVERAGE	4	0	2022	15593	1	Y N

Improvements - Accessory Buildings

Bldg: 4 Code Area: 29588 Stat Class: 353 Year Blt: 1995 Eff Year Blt: 1995 Sq.Ft: 1800 % Complete: 100
 Desc: Machine Shed (MS) Dimensions: 60x30 RMV: 11700
 Func Obsc: 100 Econ %: 100 Other %: 100 Exception: 0 Adjust: Adjust RMV: 0

Floors

Type	Class	Display Group	Floor Size	Beds	Baths	Yr Blt	Eff Yr Blt	Inventory	Exception: Y N
Machine Shed	5	Finished	1800	0	0	1995	1995	FAIR	

Accessories

Description	Class	Size SqFt	Eff Yr Blt	RMV	Quantity
No accessory data available					

Bldg: 5 Code Area: 29588 Stat Class: 351 Year Blt: 2021 Eff Year Blt: 2021 Sq.Ft: 864 % Complete: 100
 Desc: General Purpose Building (GB) Dimensions: 72x12 RMV: 25920
 Func Obsc: 100 Econ %: 100 Other %: 100 Exception: 0 Adjust: Adjust RMV: 0

Floors

Type	Class	Display Group	Floor Size	Beds	Baths	Yr Blt	Eff Yr Blt	Inventory	Exception: Y N
General Purpose Bldg	6	Finished	864	0	0	2021	2021	AVG	

Accessories

Description	Class	Size SqFt	Eff Yr Blt	RMV	Quantity
No accessory data available					

Bldg: 6 Code Area: 29588 Stat Class: 356 Year Blt: 2021 Eff Year Blt: 2021 Sq.Ft: 864 % Complete: 100
 Desc: Lean-to Excellent (LTE) Dimensions: 72x12 RMV: 8960
 Func Obsc: 100 Econ %: 100 Other %: 100 Exception: 0 Adjust: Adjust RMV: 0

Floors

Type	Class	Display Group	Floor Size	Beds	Baths	Yr Blt	Eff Yr Blt	Inventory	Exception: Y N
Lean-to Excellent	4	Finished	864	0	0	2021	2021		

Accessories

Description	Class	Size SqFt	Eff Yr Blt	RMV	Quantity
No accessory data available					

SKETCH/AREA TABLE ADDENDUM

SUBJECT INFO

File No.: 355166 Parcel No.: 081W35 00503
 Property Address: 7987 BOEDIGHEIMER RD SE
 City: SUBLIMITY County: MARION State: OR ZipCode: 97385
 Owner:
 Client:
 Client Address:
 Appraiser Name: Inspection Date:

SKETCH

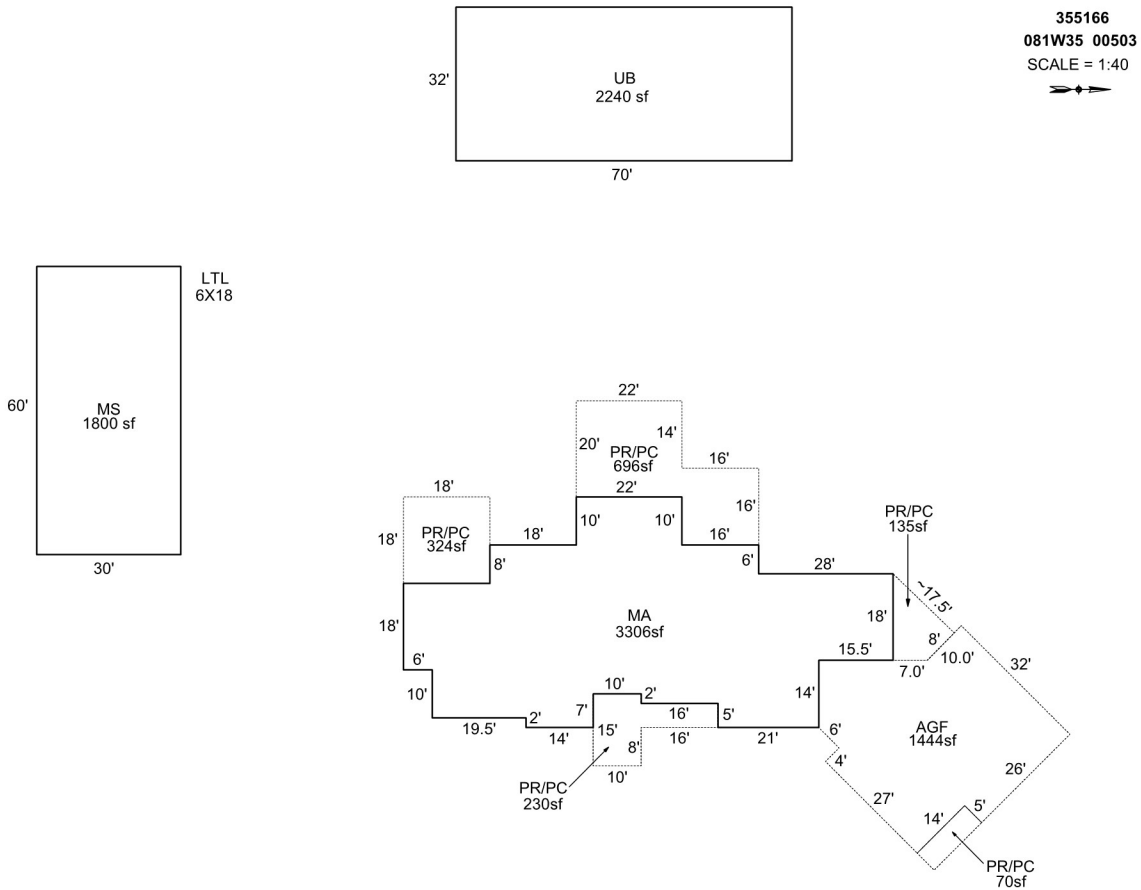

Sketch by Apex Sketch

AREA CALCULATIONS SUMMARY

Code	Description	Factor	Net Size	Perimeter	Net Totals
GBA1	UB	1.0	2240.0	204.0	
	MS	1.0	1800.0	180.0	4040.0
GLA1	MA	1.0	3306.0	314.0	3306.0
P/P	AGF	1.0	1444.2	160.7	
	PR/PC	1.0	70.0	38.0	
	PR/PC	1.0	324.0	72.0	
	PR/PC	1.0	230.0	82.0	
	PR/PC	1.0	696.0	136.0	
	PR/PC	1.0	135.0	50.8	2899.2
	Net LIVABLE	cnt	1 (rounded)		3,306
	Net BUILDING	cnt	2 (rounded)		4,040

COMMENT TABLE 1

DRAWN BY JRONDEMA 2/13/18
 UPDATED BY JRONDEMA 6/4/18
 UPDATED BY CJURAN 01/06/2022
 UPDATED BY CJURAN 01/18/2022 555-21-009872
 UPDATED BY CJURAN 03/21/2023

COMMENT TABLE 2

#10 CL 07/20/2021
 MDL 01/03/2023

COMMENT TABLE 3

CYCLE L2
 TAGS L2

SKETCH/AREA TABLE ADDENDUM

SUBJECT INFO

File No.: 355166	Parcel No.: 081W35 00503		
Property Address: 7987 BOEDIGHEIMER RD SE			
City: SUBLIMITY	County: MARION	State: OR	ZipCode: 97385
Owner:			
Client:		Client Address:	
Appraiser Name:		Inspection Date:	

SKETCH



Sketch by Apex Sketch

AREA CALCULATIONS SUMMARY

Code	Description	Factor	Net Size	Perimeter	Net Totals

COMMENT TABLE 1

DRAWN BY JRONDEMA 2/13/18
 UPDATED BY JRONDEMA 6/4/18
 UPDATED BY CJURAN 01/06/2022
 UPDATED BY CJURAN 01/18/2022 555-21-009872
 UPDATED BY CJURAN 03/21/2023

COMMENT TABLE 2

#10 CL 07/20/2021
 MDL 01/03/2023

COMMENT TABLE 3

CYCLE L2
 TAGS L2

R355166
081W35 00503
SCALE=1:40

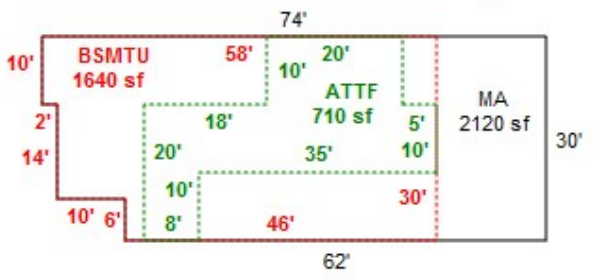
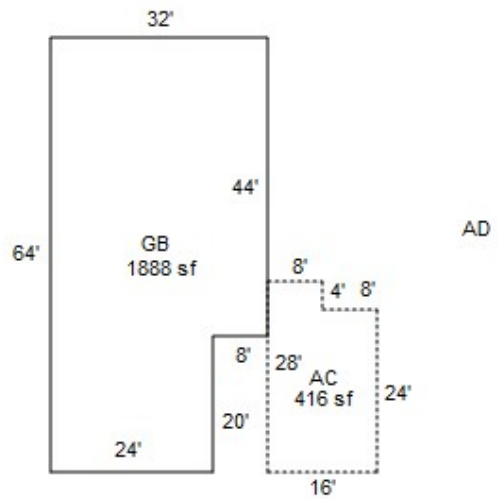
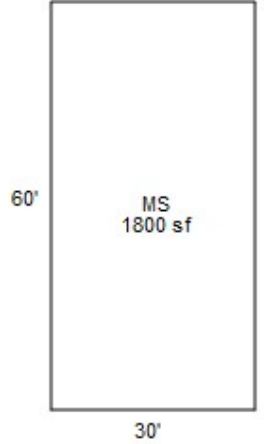
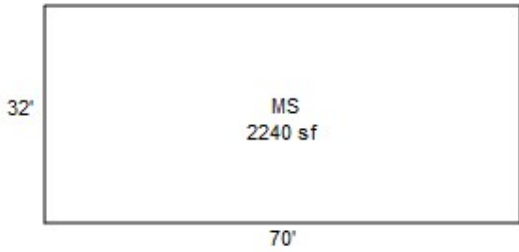

SKETCH/AREA TABLE ADDENDUM

SUBJECT INFO

File No.: 355166 Parcel No.: 081W35 00503
 Property Address: 7987 BOEDIGHEIMER RD SE
 City: SUBLIMITY County: MARION State: OR ZipCode: 97385
 Owner:
 Client: Client Address:
 Appraiser Name: Inspection Date:

SKETCH

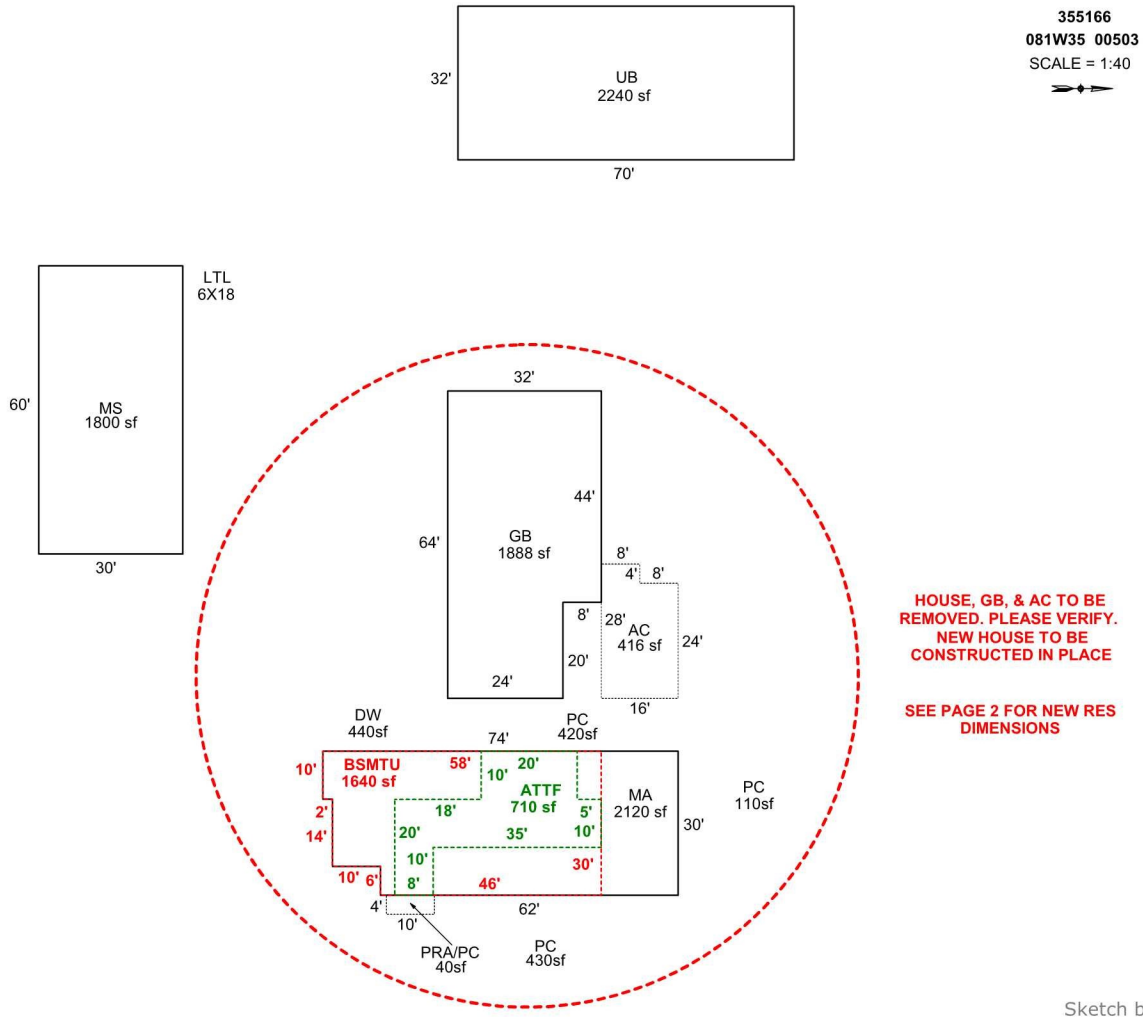

AREA CALCULATIONS SUMMARY

Code	Description	Factor	Net Size	Perimeter	Net Totals
GBA1	GB	1.0	1888.0	192.0	
	UB	1.0	2240.0	204.0	
	MS	1.0	1800.0	180.0	5928.0
GLA1	MA	1.0	2120.0	208.0	2120.0
GLA2	ATT	1.0	710.0	146.0	710.0
BSMT	BSMTU	1.0	1640.0	176.0	1640.0
GAR	AC	1.0	416.0	88.0	416.0
P/P	PRA/PC	1.0	40.0	28.0	40.0
	Net LIVABLE	cnt	2 (rounded)		2,830
	Net BUILDING	cnt	3 (rounded)		5,928

COMMENT TABLE 1

DRAWN BY JRONDEMA 2/13/18
 UPDATED BY JRONDEMA 6/4/18
 UPDATED BY CJURAN 01/06/2022
 UPDATED BY CJURAN 01/18/2022 555-21-009872

COMMENT TABLE 2

#10 CL 07/20/2021

COMMENT TABLE 3

CYCLE L2

SKETCH/AREA TABLE ADDENDUM

SUBJECT INFO

File No.: 355166 Parcel No.: 081W35 00503
 Property Address: 7987 BOEDIGHEIMER RD SE
 City: SUBLIMITY County: MARION State: OR ZipCode: 97385
 Owner:
 Client: Client Address:
 Appraiser Name: Inspection Date:

SKETCH

355166
081W35 00503
 SCALE = 1:20



SEE PAGE 1 FOR
 FULL LAYOUT

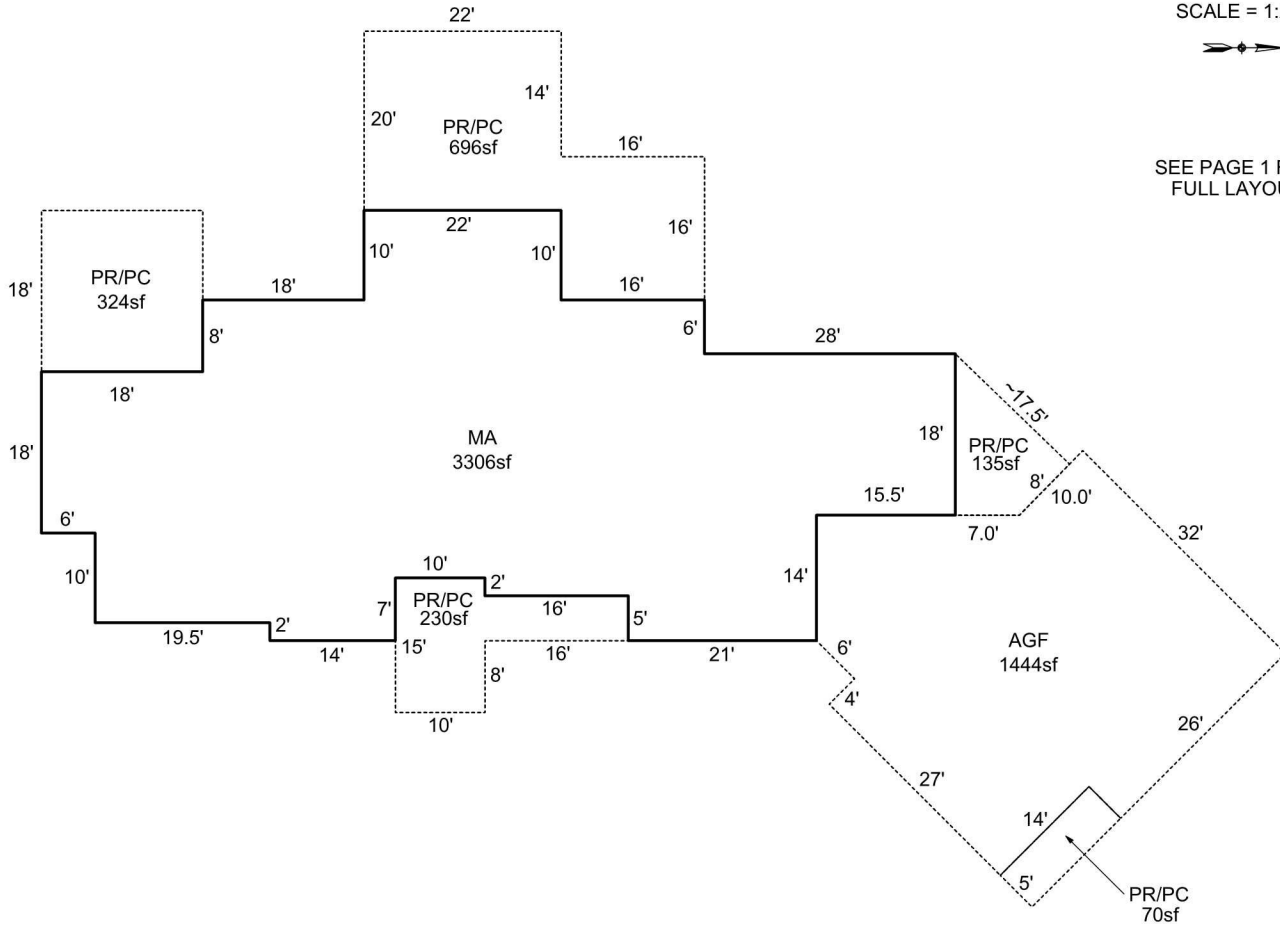

Sketch by Apex Sketch

AREA CALCULATIONS SUMMARY

COMMENT TABLE 1

Code	Description	Factor	Net Size	Perimeter	Net Totals
GLA1	MA	1.0	3306.0	314.0	3306.0
P/P	PR/PC	1.0	324.0	72.0	
	PR/PC	1.0	696.0	136.0	
	PR/PC	1.0	135.0	50.8	
	PR/PC	1.0	70.0	38.0	
	PR/PC	1.0	230.0	82.0	
	AGF	1.0	1444.2	160.7	2899.2

DRAWN BY JRONDEMA 2/13/18
 UPDATED BY JRONDEMA 6/4/18
 UPDATED BY CJURAN 01/06/2022
 UPDATED BY CJURAN 01/18/2022 555-21-009872

COMMENT TABLE 2

COMMENT TABLE 3

#10 CL 07/20/2021

CYCLE L2

Net LIVABLE cnt 1 (rounded) 3,306

