

Summary Lead Appr: WW Clerk: _____ Lead Clerk: _____ Appr: MDL Input Print Date: 1/25/2024

Acct ID: 330768 MTL: 093W35CD01300 Date: 7/9/24 Appr: MDL Prop Class: 401 RMV Prop Class: 401
 Situs: 14941 LAUREL LN SE JEFFERSON OR 97352 MaSaNh: 07 06 000 Unit: 55169 Year: 2024

Last Date Appraised: 08/16/2023 Appraiser: MATT LORD Retag: Y N Tag info: 2024 - Tags/Permit (Completion)
 Owner: CUTLER, DALLAS Roll Type: R
 Cycle Tag Sales Verification Other: _____ Inspection level: 1 2 3 4 LCB TTO INSP AV: 370340
 RMV Land: 231920 RMV Imp: 470060 RMV Total: 701980 MAV: 370340 MSAV: 0 SAV: 0
 Comment: 23-24 8.16.23 L2 MDL
 1-6-22 L2 Mlord

Notations 24-25 cycle
 No notation data available.

OSDs

Count	Code	Description	RMV	Code Area	Exception
1	MKTA	OSD - AVERAGE	45000	14530	0

Land

Site: 1 Code Area: 14530 Size: 1.50 Acres Use Code: 004 Zone: NREST SAV Use: Exception: 0
 Class: 4BDS Value Source: Rural at MKT Description: FOUR BENCH DRY SPECIAL SOUTH RMV: 186920 Exception: Y N
 S
 Adjustment(s): Fire Patrol: Description:
 Comments: 18-19: #11 CYCLE WORK, NO CHG //8-7-08(GW39): Maintain flat value until road and utility improvements are completed and lots can be sold. Then establish new RMV and process SUBE exception//03-04: L&L SUBDIVISION MERGING INTO SURROUNDING AREA 03-04: REAPPRAISAL //03-04: T03-51K REDUCTION OF MKT AND AV FOR LAND,FREEZE VALUE TILL 1-1-05 //04-05: CHG OF LAND SCHEDULE PER #29 //05-06: EDIT LIST- PER #29, FLAT VALUE THE LAND

Improvements - Residence / Manufactured Structures

Bldg: 1 Code Area: 14530 Stat Class: 141 Year Blt: 2021 Eff Year Blt: 2021 Sq.Ft: 2538 % Complete: 100
 Desc: One Story Only Dimensions: RMV: 412300
 Func Obsc: 100 Econ %: 100 Other %: 100 Exception: 0 Adjust: Adjust RMV: 0

Floors

Type	Class	Display Group	Floor Size	Beds	Baths	Yr Blt	Eff Yr Blt	Inventory	Exception
First Floor	4	Finished	2538	3	FB-2/ HB-1	2021	2021	FP - 1, HVAC+, ROOF, KIT+, BTH - 1, BATH - 2	Y N
Garage Attached	4	Finished	744	0	0	2021	2021	ROOF	Y N

Accessories

Description	Class	Size SqFt	Eff Yr Blt	RMV	Quantity	Exception
YARD IMPROVEMENTS AVERAGE	4	0	2021	27621	1	Y N

Improvements - Accessory Buildings

Bldg: 2 Code Area: 14530 Stat Class: 351 Year Blt: 2021 Eff Year Blt: 2021 Sq.Ft: 1920 % Complete: 100
 Desc: General Purpose Building (GB) Dimensions: 32x60, 21x30 RMV: 57760
 Func Obsc: 100 Econ %: 100 Other %: 100 Exception: 0 Adjust: Adjust RMV: 0

Floors

Type	Class	Display Group	Floor Size	Beds	Baths	Yr Blt	Eff Yr Blt	Inventory	Exception
General Purpose Bldg	5	Finished	1920	0	HB-1	2021	2021	FAIR, BTH - 1	Y N
GP Building Attic	5	Unfinished	630	0	0	2021	2021		Y N

Accessories

PKG A

Description	Class	Size SqFt	Eff Yr Blt	RMV	Quantity
No accessory data available					

SKETCH/AREA TABLE ADDENDUM

SUBJECT INFO

File No.: 330768 Parcel No.: 093W35CD01300
 Property Address: 14941 LAUREL LANE
 City: JEFFERSON County: MARION State: OR ZipCode:
 Owner:
 Client: Client Address:
 Appraiser Name: Inspection Date:

SKETCH

330768
093W35CD01300
 SCALE=1:20

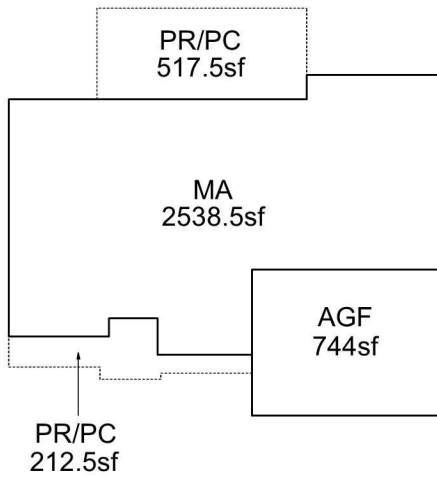
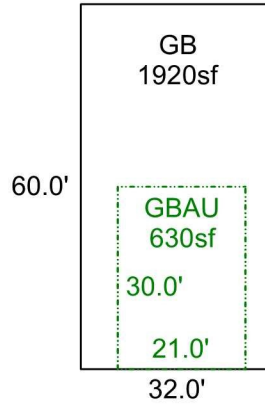

SEE PAGE 1 FOR
RES DIMENSIONS

Sketch by Apex Sketch

AREA CALCULATIONS SUMMARY

Code	Description	Factor	Net Size	Perimeter	Net Totals
GBA1	GB	1.0	1920.0	184.0	1920.0
GBA2	GBAU	1.0	630.0	102.0	630.0
GLA1	MA	1.0	2538.5	240.0	2538.5
GAR	AGF	1.0	744.0	110.0	744.0
P/P	PR/PC	1.0	212.5	100.0	
	PR/PC	1.0	517.5	99.0	730.0

COMMENT TABLE 1

APEX BY CJURAN 10/18/2021 555-21-008211
& 555-21-008213

COMMENT TABLE 2

COMMENT TABLE 3

Net LIVABLE	cnt	1	(rounded)		2,539
Net BUILDING	cnt	2	(rounded)		2,550

SKETCH/AREA TABLE ADDENDUM

SUBJECT INFO

File No.: 330768 Parcel No.: 093W35CD01300
 Property Address: 14941 LAUREL LANE
 City: JEFFERSON County: MARION State: OR ZipCode:
 Owner:
 Client: Client Address:
 Appraiser Name: Inspection Date:

SKETCH

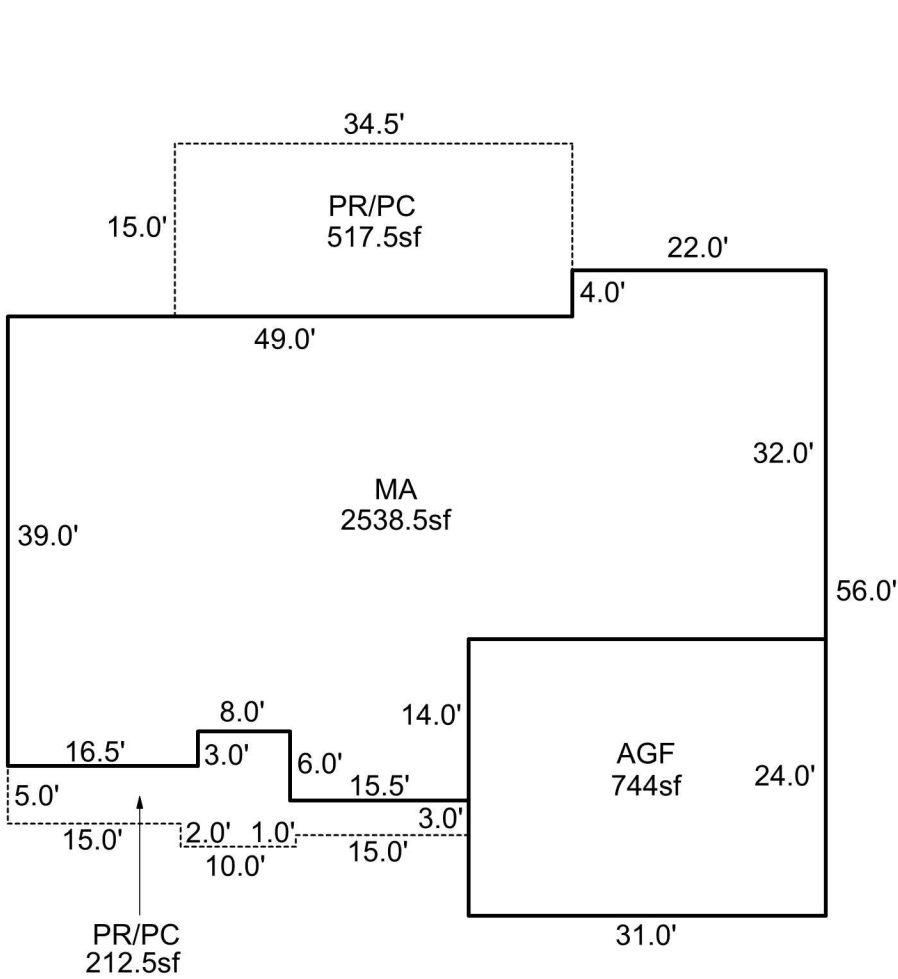

Sketch by Apex Sketch

AREA CALCULATIONS SUMMARY

Code	Description	Factor	Net Size	Perimeter	Net Totals
GLA1	MA	1.0	2538.5	240.0	2538.5
GAR	AGF	1.0	744.0	110.0	744.0
P/P	PR/PC	1.0	517.5	99.0	
	PR/PC	1.0	212.5	100.0	730.0

COMMENT TABLE 1

APEX BY CJURAN 10/18/2021 555-21-008211 & 555-21-008213

COMMENT TABLE 2

COMMENT TABLE 3

Net LIVABLE cnt 1 (rounded) 2,539



330768 Front SFD 2022-01-07
L2

2022. 1. 7



330768 Front GB 2022-01-07
L2

2022. 1. 7

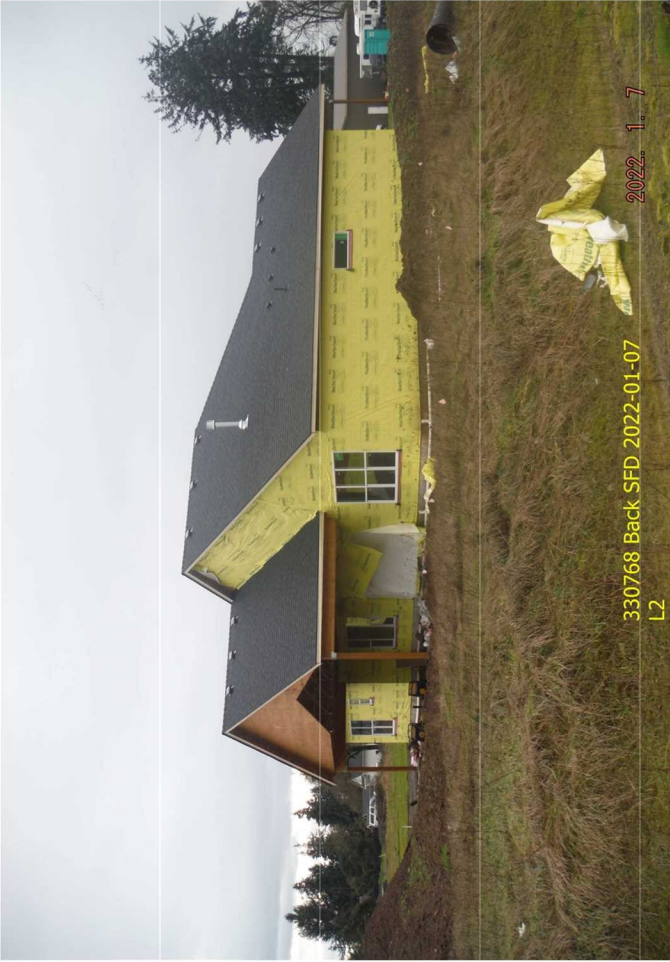

330768 Back SFD 2022-01-07
L2

2022. 1. 7

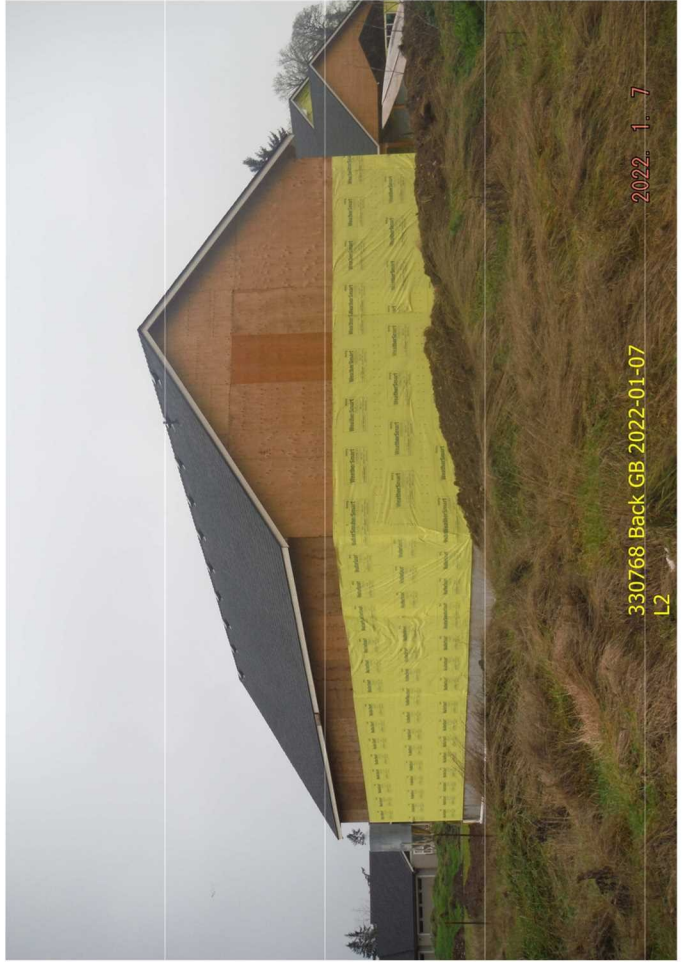

330768 Back GB 2022-01-07
L2

2022. 1. 7



R330768
8/15/2018