

Summary Lead Appr: WW Clerk: _____ Lead Clerk: _____ Appr: MDL Print Date: 7/31/2023

Acct ID: 536167 MTL: 093W04D000200 Date: 1/8/24 Appr: MDL Prop Class: 401 RMV Prop Class: 401
Situs: 9451 LIBERTY RD S SALEM OR 97306 MaSaNh: 07 06 000 Unit: 62919 Year: ~~2023~~
2024

Last Date Appraised: 04/05/2023 Appraiser: MATT LORD Retag: Y N Tag info: 2024 - NEW CONSTRUCTION (Residence)

Owner: MURAVEZ, JOSHUA A Roll Type: R

Cycle: Tag Sales Verification Other: _____ Inspection level: 1 2 3 4 LCB TTO INSP AV: 61730

RMV Land: 157800 RMV Imp: 2660 RMV Total: 160460 MAV: 61730 MSAV: 0 SAV: 0

Comment: 23-24: L2 12.15.22 ✓ CLOSER TO 1/1/24 GATED could not GET photo, No response from owner
23-24: L4 4.5.23 MDL
22-23: L4 11.09.2022 MDL

Notations 24.25: NSFJ 4BD/4BA 23-003196 100% complete

No notation data available.

OSDs

Count	Code	Description	RMV	Code Area	Exception
1	MKTF	OSD - FAIR	35000	92000	0

Land

Site: 1 Code Area: 92000 Size: 1.15 Acres Use Code: 004 Zone: NREST SAV Use: Exception: 0
 Class: 4HD Value Source: Rural at MKT Description: FOUR HILL DRY RMV: 122800 Exception: Y N
 Adjustment(s): Fire Patrol: Description:
 Comments: 01-02: REAPPRAISAL

Improvements - Residence / Manufactured Structures

No residence or manufactured structure improvement data available.

Improvements - Accessory Buildings

Bldg: 1 Code Area: 92000 Stat Class: 341 Year Blt: 1985 Eff Year Blt: 1974 Sq.Ft: 280 % Complete: 100
 Desc: Multi Purpose Shed (MP) Dimensions: 20x14 RMV: 2660
 Func Obsc: 100 Econ %: 100 Other %: 100 Exception: 0 Adjust: Adjust RMV: 0

Floors

Type	Class	Display Group	Floor Size	Beds	Baths	Yr Blt	Eff Yr Blt	Inventory
Multi-Purpose Bldg	6	Finished	280	0	0	1985	1974	Exception: Y N

Accessories

Description	Class	Size SqFt	Eff Yr Blt	RMV	Quantity
-------------	-------	-----------	------------	-----	----------

No accessory data available

ACCOUNT # 536167 DATE: 1/8/24 RMV CLASS 401 PROP CLASS 401
 MTL 93w HD 200 APPR MDL TAG Y N

COMMENTS: _____

RESIDENCE / MANUFACTURED STRUCTURES

ACCESSORY IMPROVEMENTS / OUTBUILDINGS

STAT 4 QLTY + - FLOOR MA
 AREA 1802 EFF AREA 1802 BED 1
 ROOF + HVAC +
 BATH PKG: 1 BATH 1 BATH + 1 1/2 BTH
 FIREPLACE: 1
 KITCHEN - +
 YR BLT 2023 EFF YR 2023 ECON _____
 % COMP 100 % GOOD _____ FUNC _____
 EXCEPT Y N LUMP SUM: _____
 MISC: _____

YI CLASS 4 F G A E
 SKIRT + LIN FT _____
 COMMENT: _____

STAT 4 QLTY + - FLOOR MA2
 AREA 1011 EFF AREA 1011 BED 3
 ROOF + HVAC +
 BATH PKG: 2 BATH 1 BATH + 1 1/2 BTH
 FIREPLACE: _____
 KITCHEN - +
 YR BLT 2023 EFF YR 2023 ECON _____
 % COMP 100 % GOOD _____ FUNC _____
 EXCEPT Y N LUMP SUM: _____
 MISC: _____

YI CLASS _____ F G A E
 SKIRT + LIN FT _____
 COMMENT: _____

STAT _____ QLTY + - FLOOR _____
 AREA _____ EFF AREA _____ BED _____
 ROOF + HVAC +
 BATH PKG: _____ BATH _____ BATH + _____ 1/2 BTH
 FIREPLACE: _____
 KITCHEN - +
 YR BLT _____ EFF YR _____ ECON _____
 % COMP _____ % GOOD _____ FUNC _____
 EXCEPT Y N LUMP SUM: _____
 MISC: _____

YI CLASS _____ F G A E
 SKIRT + LIN FT _____
 COMMENT: _____

TYPE ATTF
 STAT / CLASS 4+
 SIZE 348
 FAIR
AVERAGE
 GOOD
 EXCELLENT
 BATH _____

YR BLT 2023
 EFF YR 2023
 % COMP 100
 EXCEPT Y N
 MISC: _____

COMMENT: _____

TYPE _____
 STAT / CLASS _____
 SIZE _____
 FAIR
 AVERAGE
 GOOD
 EXCELLENT
 BATH _____

YR BLT _____
 EFF YR _____
 % COMP _____
 EXCEPT Y N
 MISC: _____

COMMENT: _____

TYPE ABF
 STAT / CLASS 4
 SIZE 872
 FAIR
AVERAGE
 GOOD
 EXCELLENT
 BATH _____

YR BLT 2023
 EFF YR 2023
 % COMP 100
 EXCEPT Y N
 MISC: _____

COMMENT: _____

TYPE _____
 STAT / CLASS _____
 SIZE _____
 FAIR
 AVERAGE
 GOOD
 EXCELLENT
 BATH _____

YR BLT _____
 EFF YR _____
 % COMP _____
 EXCEPT Y N
 MISC: _____

COMMENT: _____

SKETCH/AREA TABLE ADDENDUM

SUBJECT INFO

File No.: 536167 Parcel No.: 093W04D 00200
 Property Address: 9451 LIBERTY ROAD S.
 City: TURNER County: MARION State: OR ZipCode: 97306
 Owner:
 Client: Client Address:
 Appraiser Name: Inspection Date:

SKETCH

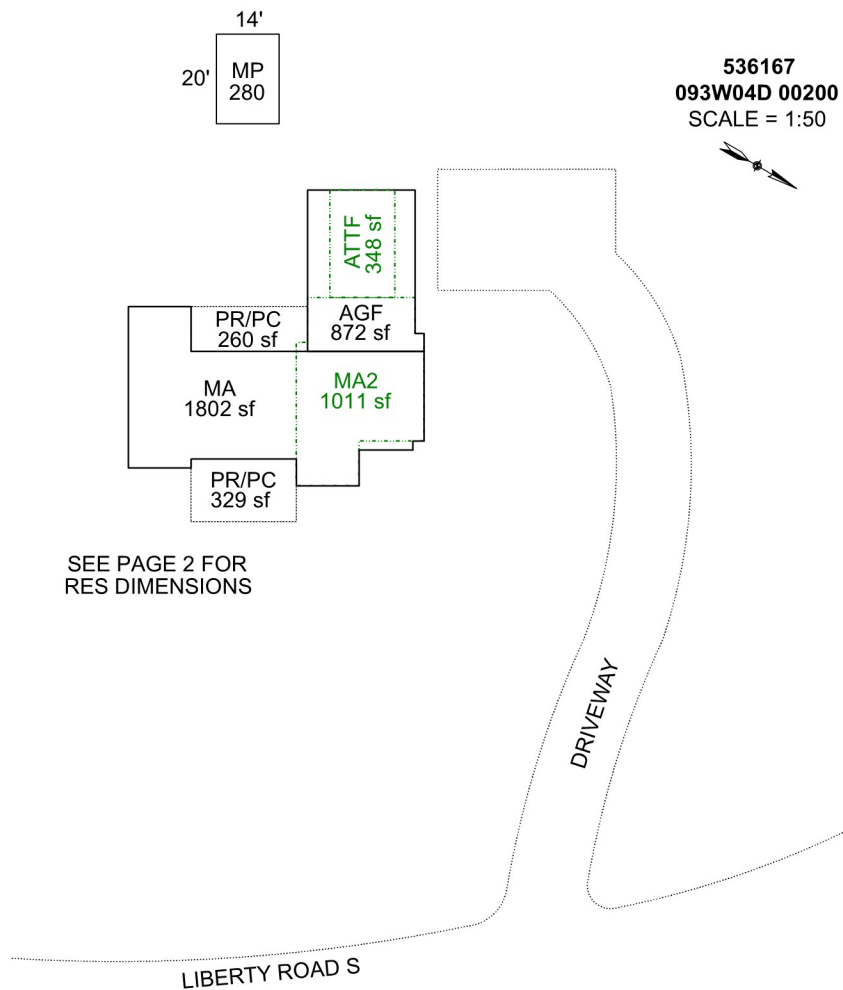

Sketch by Apex Sketch

AREA CALCULATIONS SUMMARY

Code	Description	Factor	Net Size	Perimeter	Net Totals
GLA1	MA	1.0	1802.0	216.0	1802.0
GLA2	MA2	1.0	1011.0	141.0	
	ATTF	1.0	348.0	77.0	1359.0
GAR	AGF	1.0	872.0	124.0	872.0
OTH	MP	1.0	280.0	68.0	280.0
P/P	PR/PC	1.0	260.0	72.0	
	PR/PC	1.0	329.0	75.0	589.0

COMMENT TABLE 1

Apex by JA 11/10/09
 UPDATED BY CJURAN 05/11/2021 555-21-003591
 UPDATED BY CJURAN 02/08/2023
 UPDATED BY CJURAN 06/14/2023 555-23-003196

COMMENT TABLE 2

MDL 12/15/2022

COMMENT TABLE 3

TAGS/PERMITS L2

Net LIVABLE cnt 3 (rounded) 3,161

SKETCH/AREA TABLE ADDENDUM

SUBJECT INFO

File No.: 536167 Parcel No.: 093W04D 00200
 Property Address: 9451 LIBERTY ROAD S.
 City: TURNER County: MARION State: OR ZipCode: 97306
 Owner:
 Client: Client Address:
 Appraiser Name: Inspection Date:

SKETCH

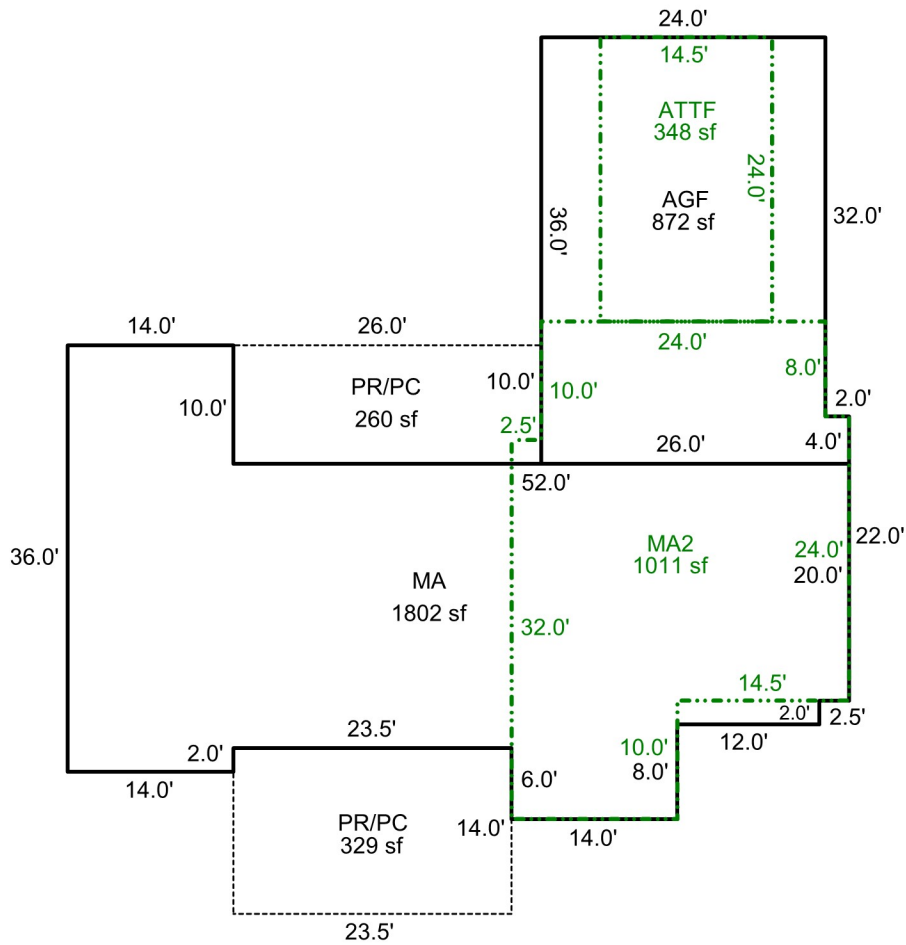

536167
093W04D 00200
 SCALE = 1:50

SEE PAGE 1 FOR
 ALL BLDGS

Sketch by Apex Sketch

AREA CALCULATIONS SUMMARY

Code	Description	Factor	Net Size	Perimeter	Net Totals
GLA1	MA	1.0	1802.0	216.0	1802.0
GLA2	MA2	1.0	1011.0	141.0	
	ATTF	1.0	348.0	77.0	1359.0
GAR	AGF	1.0	872.0	124.0	872.0
P/P	PR/PC	1.0	260.0	72.0	
	PR/PC	1.0	329.0	75.0	589.0

COMMENT TABLE 1

Apex by JA 11/10/09
 UPDATED BY CJURAN 05/11/2021 555-21-003591
 UPDATED BY CJURAN 02/08/2023
 UPDATED BY CJURAN 06/14/2023 555-23-003196

COMMENT TABLE 2

MDL 12/15/2022

COMMENT TABLE 3

TAGS/PERMITS L2

Net LIVABLE cnt 3 (rounded) 3,161

