

Summary Lead Appr: WW Clerk: Lead Clerk: Appr: MNL Input Print Date: 6/14/2024

Acct ID: 536333 MTL: 093W15A000500 Date: 5/17/24 Appr: MNL Prop Class: 551 RMV Prop Class: 551
Situs: 11413 HOCHSPEIER RD SE JEFFERSON OR 97352 MaSaNh: 07 06 000 Unit: 25789 Year: 2024

Last Date Appraised: 03/02/2012 Appraiser: MATT LORD Retag: Y N Tag info:
Owner: HOCHSPEIER TR & Roll Type: R
Cycle Tag Sales Verification Other: Inspection level: 1 2 3 4 LCB TTO INSP AV: 425309
RMV Land: 370710 RMV Imp: 596140 RMV Total: 966850 MAV: 397440 MSAV: 27869 SAV: 48034
Comment:

Notations

24-25 cycle

RP/MS	Code	Description
RP	ZONED	FARM EFU ZONED

OSDs

Count	Code	Description	RMV	Code Area	Exception
1	SAA	SA OSD - AVERAGE	45000	14530	0

Land

Site: 1 Code Area: 14530 Size: 1.00 Acres Use Code: 005 Zone: REST SAV Use: 011 Exception: 0
Class: Value Source: Farm Homesite Description: RMV: 16060 Exception: Y N

Adjustment(s): GSOIL, FSOIL

Fire Patrol: Description:

Comments: Liability year - 2009 / //09-10: GW39 changed land type per Excel analysis** PER 342- CHG OF SOIL CLASS FROM 4HILL TO 2HILL, 6HILL AND 4HILL//81400130, 00-01: separation of homesite from inc /03-04: REAPPRAISAL

Site: 2 Code Area: 14530 Size: 10.20 Acres Use Code: 005 Zone: REST SAV Use: 011 Exception: 0
Class: 4BDS Value Source: Farm Use - EFU Description: FOUR BENCH DRY SPECIAL SOUTH RMV: 163860 Exception: Y N

Adjustment(s): GSOIL, FSOIL

Fire Patrol: Description:

Comments: Liability year - 1980 / 10-11: DISQ 4 AC FARM DEFERRAL// 81400130: 01-02; CHANGED SOIL CLASS FROM 3 HILL DRY TO 4 HILL DRY

Site: 4 Code Area: 14530 Size: 2.80 Acres Use Code: 005 Zone: REST SAV Use: 011 Exception: 0
Class: 2BDS Value Source: Farm Use - EFU Description: TWO BENCH DRY SOUTH SPECIAL RMV: 49480 Exception: Y N

Adjustment(s): GSOIL, FSOIL

Fire Patrol: Description:

Comments: Liability year - 1980 / 81400130: 01-02; CHANGED SOIL CLASS FROM 3 HILL DRY TO 4 HILL DRY

Site: 5 Code Area: 14530 Size: 2.10 Acres Use Code: 005 Zone: REST SAV Use: 011 Exception: 0
Class: 6H Value Source: Farm Use - EFU Description: SIX HILL RMV: 32050 Exception: Y N

Adjustment(s): GSOIL, FSOIL

Fire Patrol: Description:

Comments: Liability year - 1980 / 81400130: 01-02; CHANGED SOIL CLASS FROM 3 HILL DRY TO 4 HILL DRY

Site: 6 Code Area: 14530 Size: 4.00 Acres Use Code: 005 Zone: REST SAV Use: Exception: 0
Class: Value Source: Rural Restrictive Description: RMV: 64260 Exception: Y N

Adjustment(s): GSOIL, FSOIL

Fire Patrol: Description:

Comments: 10-11: DISQ 4 AC FARM DEFERRAL// 81400130: 01-02; CHANGED SOIL CLASS FROM 3 HILL DRY TO 4 HILL DRY

Improvements - Residence / Manufactured Structures

Bldg: 2 Code Area: 14530 Stat Class: 144 + Year Blt: 2002 Eff Year Blt: 2002 Sq.Ft: 2487 % Complete: 100

Desc: Multi Story above grade with basement

Dimensions: RMV: 471240

Func Obsc: 100 Econ %: 100 Other %: 100 Exception: 0 Adjust: Adjust RMV: 0

Floors

Type	Class	Display Group	Floor Size	Beds	Baths	Yr Blt	Eff Yr Blt	Inventory	Exception: Y N
First Floor	4 +	Finished	2487	4	FB-2/ HB-1	2002	2002	BATH - 2, BTH - 1, KIT+, ROOF, HVAC+	Exception: Y N
Attic	4 +	Unfinished	464	0	0	2002	2002		Exception: Y N
Basement	4 +	Unfinished	448	0	0	2002	2002		Exception: Y N
Garage Attached	4	Finished	690	0	0	2002	2002	ROOF	Exception: Y N

Accessories

Description	Class	Size SqFt	Eff Yr Blt	RMV	Quantity	Exception: Y N
YARD IMPROVEMENTS AVERAGE	4	1	2002	25110	1	Exception: Y N

Improvements - Accessory Buildings

Bldg: 1 Code Area: 14530 Stat Class: 351 Year Blt: 2001 Eff Year Blt: 2002 Sq.Ft: 3500 % Complete: 100

Desc: General Purpose Building (GB)

Dimensions: 50x70 RMV: 39900

Func Obsc: 100 Econ %: 100 Other %: 100 Exception: 0 Adjust: Adjust RMV: 0

Floors

Type	Class	Display Group	Floor Size	Beds	Baths	Yr Blt	Eff Yr Blt	Inventory	
General Purpose Bldg	5	Finished	3500	0	0	2001	2002	FAIR	Exception: Y N

Accessories

Description	Class	Size SqFt	Eff Yr Blt	RMV	Quantity
No accessory data available					

Bldg: 3	Code Area: 14530	Stat Class: 307	Year Blt: 2011	Eff Year Blt: 2011	Sq.Ft: 0	% Complete: 100
Desc: Wind Turbine				Dimensions: RMV: 62000		
Func Obsc: 100	Econ %: 100	Other %: 100	Exception: 0	Adjust:	Adjust RMV: 0	

Floors

Type	Class	Display Group	Floor Size	Beds	Baths	Yr Blt	Eff Yr Blt	Inventory
No floor data available								

Accessories

Description	Class	Size SqFt	Eff Yr Blt	RMV	Quantity
WIND TURBINE	0	0	2011	62000	1
Exception: Y N					

Bldg: 5	Code Area: 14530	Stat Class: 905	Year Blt: 2007	Eff Year Blt: 2007	Sq.Ft: 0	% Complete: 100
Desc: Rural Solar Panel/Array				Dimensions: RMV: 23000		
Func Obsc: 100	Econ %: 100	Other %: 100	Exception: 0	Adjust:	Adjust RMV: 0	

Floors

Type	Class	Display Group	Floor Size	Beds	Baths	Yr Blt	Eff Yr Blt	Inventory
No floor data available								

Accessories

Description	Class	Size SqFt	Eff Yr Blt	RMV	Quantity
No accessory data available					

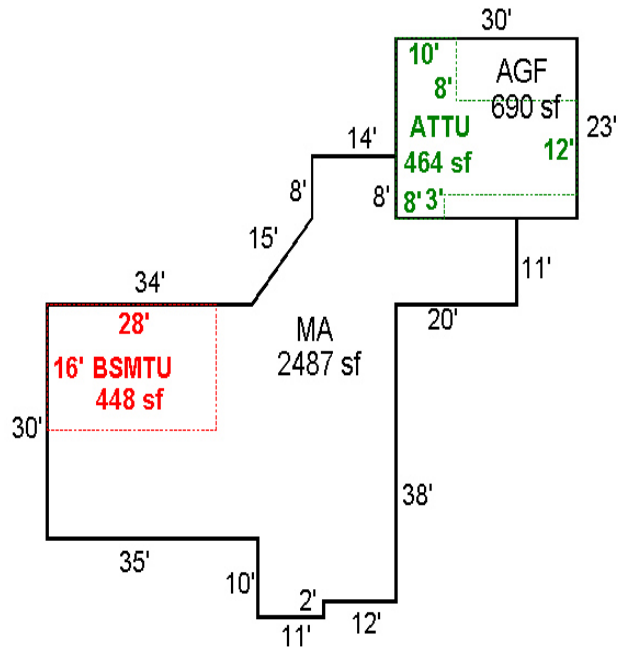

R36333
 093W15A 00500

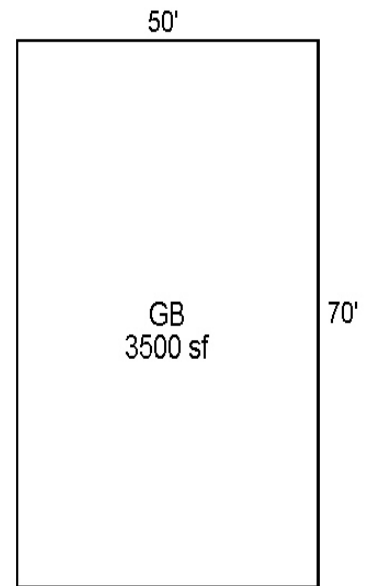





5/17/24



5/17/24