

Acct ID: 564506 MTL: 092W13A001400 Date: **1/9/24** Appr: **MDL** Prop Class: 551 RMV Prop Class: 551
 Situs: 9457 SNODDY DR SE AUMSVILLE OR 97325 MaSaNh: 07 06 000 Unit: 104381 Year: 2024

Last Date Appraised: 02/16/2018 Appraiser: MATT LORD Retag: **Y** N Tag info: **2024 - Tags/Permit (Addition)**

Owner: PARSONS, THOMAS Roll Type: R

Cycle **Tag** Sales Verification Other: **Aerial** Inspection level: 1 2 **3** **4** LCB TTO INSP AV: 130768

RMV Land: 228920 RMV Imp: 170670 RMV Total: 399590 MAV: 82190 MSAV: 48578 SAV: 74513

Comment: **23-005642 Addition/Remodel Gate to outbndry**

Notations

NO START ✓ 1/11/25 DEMO HC

RP/MS	Code	Description
RP	ZONED	FARM EFU ZONED

OSDs

Count	Code	Description	RMV	Code Area	Exception
1	SAA	SA OSD - AVERAGE	45000	05545	0

Land

Site: 1 Code Area: 05545 Size: 1.00 Acres Use Code: 005 Zone: REST SAV Use: 011 Exception: 0
 Class: Value Source: Farm Homesite Description: RMV: 60770 Exception: Y N
 Adjustment(s): IRR Fire Patrol: Description:
 Comments: Liability year - 2009 / 0055040

Site: 3 Code Area: 05545 Size: 1.93 Acres Use Code: 005 Zone: REST SAV Use: 011 Exception: 0
 Class: 4BISS Value Source: Farm Use - EFU Description: FOUR BENCH IRR SPECIAL SOUTH RMV: 123150 Exception: Y N
 Adjustment(s): IRR Fire Patrol: Description:
 Comments: Liability year - 1980 / 00550040

Improvements - Residence / Manufactured Structures

Bldg: 1 Code Area: 05545 Stat Class: 132 Year Blt: 1950 Eff Year Blt: 1950 Sq.Ft: 1608 % Complete: 100
 Desc: Multi Story above grade Dimensions: RMV: 150420
 Func Obsc: 100 Econ %: 100 Other %: 100 Exception: 0 Adjust: Adjust RMV: 0

Floors

Type	Class	Display Group	Floor Size	Beds	Baths	Yr Blt	Eff Yr Blt	Inventory	Exception
First Floor	3	Finished	1248	3	FB-1	1950	1950	ROOF, HVAC, KIT-, BATH - 1	Y N
Attic	3	Finished	360	1	0	1950	1950		Y N
Garage Attached	3	Unfinished	480	0	0	1950	1950	ROOF	Y N

Accessories

Description	Class	Size SqFt	Eff Yr Blt	RMV	Quantity	Exception
ENCLOSED PORCH	3	120	1950	2412	1	Y N
YARD IMPROVEMENTS AVERAGE	2	1	1950	6231	1	Y N

Improvements - Accessory Buildings

Bldg: 2 Code Area: 05545 Stat Class: 341 Year Blt: 1981 Eff Year Blt: 1981 Sq.Ft: 168 % Complete: 100
 Desc: Multi Purpose Shed (MP) Dimensions: 14x12 RMV: 790
 Func Obsc: 100 Econ %: 100 Other %: 100 Exception: 0 Adjust: Adjust RMV: 0

Floors

Type	Class	Display Group	Floor Size	Beds	Baths	Yr Blt	Eff Yr Blt	Inventory	Exception
Multi-Purpose Bldg	4	Finished	168	0	0	1981	1981	FAIR	Y N

Accessories

No accessory data available

Bldg: 3 Code Area: 05545 Stat Class: 312 Year Blt: 1971 Eff Year Blt: 1971 Sq.Ft: 480 % Complete: 100
 Desc: Loft Barn (LB) Dimensions: 24x20 RMV: 1530
 Func Obsc: 50 Econ %: 100 Other %: 100 Exception: 0 Adjust: Adjust RMV: 0

Floors

Type	Class	Display Group	Floor Size	Beds	Baths	Yr Blt	Eff Yr Blt	Inventory	Exception
Loft Barn	4	Finished	480	0	0	1971	1971	FAIR	Y N

Accessories

Description	Class	Size SqFt	Eff Yr Blt	RMV	Quantity				
No accessory data available									
Bldg: 4	Code Area: 05545	Stat Class: 351	Year Blt: 2000	Eff Year Blt: 2000	Sq.Ft: 1152	% Complete: 100			
Desc: General Purpose Building (GB)			Dimensions: 48x24			RMV: 16420			
Func Obsc: 100	Econ %: 100	Other %: 100	Exception: 0	Adjust:	Adjust RMV: 0				
Floors									
Type	Class	Display Group	Floor Size	Beds	Baths	Yr Blt	Eff Yr Blt	Inventory	
General Purpose Bldg	6	Finished	1152	0	0	2000	2000	FAIR	Exception: Y N
Accessories									
Description	Class	Size SqFt	Eff Yr Blt	RMV	Quantity				
No accessory data available									
Bldg: 5	Code Area: 05545	Stat Class: 321	Year Blt:	Eff Year Blt:	Sq.Ft: 200	% Complete: 100			
Desc: Hay Cover (HC)			Dimensions: 10x20			RMV: 1510			
Func Obsc: 100	Econ %: 100	Other %: 100	Exception: 0	Adjust:	Adjust RMV: 0				
Floors									
Type	Class	Display Group	Floor Size	Beds	Baths	Yr Blt	Eff Yr Blt	Inventory	
Hay Cover	5	Finished	200	0	0	0	0	FAIR	Exception: Y N
Accessories									
Description	Class	Size SqFt	Eff Yr Blt	RMV	Quantity				
No accessory data available									

Demo

SKETCH/AREA TABLE ADDENDUM

SUBJECT INFO

File No.: 564506 Parcel No.: 092W13A 01400
 Property Address: 9457 SNODDY DR SE
 City: AUMSVILLE County: MARION State: OR ZipCode: 97325
 Owner:
 Client:
 Appraiser Name: Client Address:
 Inspection Date:

SKETCH

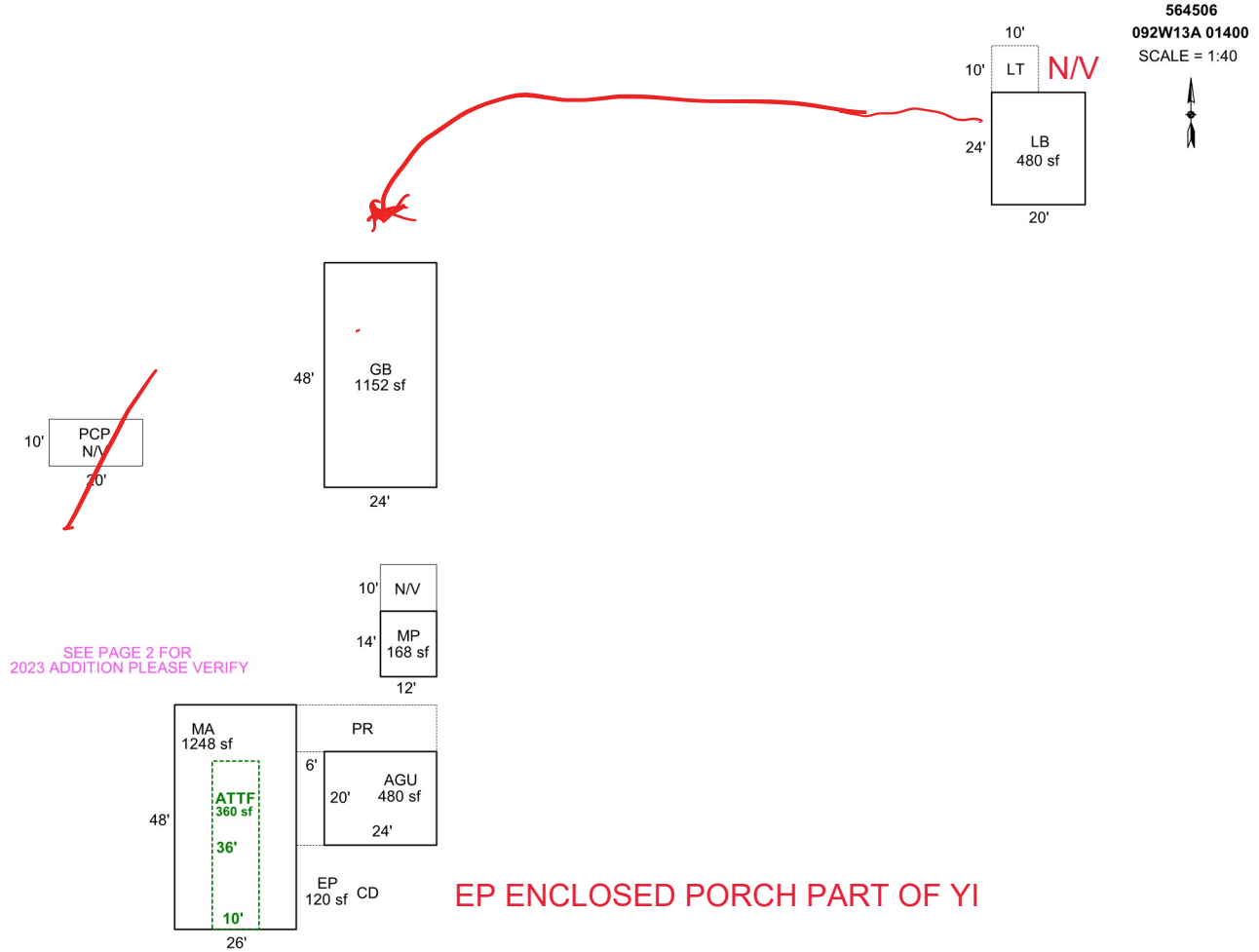

Sketch by Apex Sketch

AREA CALCULATIONS SUMMARY

Code	Description	Factor	Net Size	Perimeter	Net Totals
GBA1	GB	1.0	1152.0	144.0	
	MP	1.0	168.0	52.0	
	LB	1.0	480.0	88.0	1800.0
GLA1	MA	1.0	1248.0	148.0	1248.0
GLA2	ATTF	1.0	360.0	92.0	360.0
GAR	AGU	1.0	480.0	88.0	480.0
P/P	EP	1.0	120.0	52.0	120.0

COMMENT TABLE 1

DRAWN BY JRONDEMA 3/31/17
 UPDATED BY JRONDEMA 2/22/18
 UPDATED BY CJURAN 09/28/2023 23-005642 AD

COMMENT TABLE 2

COMMENT TABLE 3

Net LIVABLE	cnt	2	(rounded)		1,608
Net BUILDING	cnt	3	(rounded)		1,800

SKETCH/AREA TABLE ADDENDUM

SUBJECT INFO

File No.: 564506 Parcel No.: 092W13A 01400
 Property Address: 9457 SNODDY DR SE
 City: AUMSVILLE County: MARION State: OR ZipCode: 97325
 Owner:
 Client: Client Address:
 Appraiser Name: Inspection Date:

SKETCH

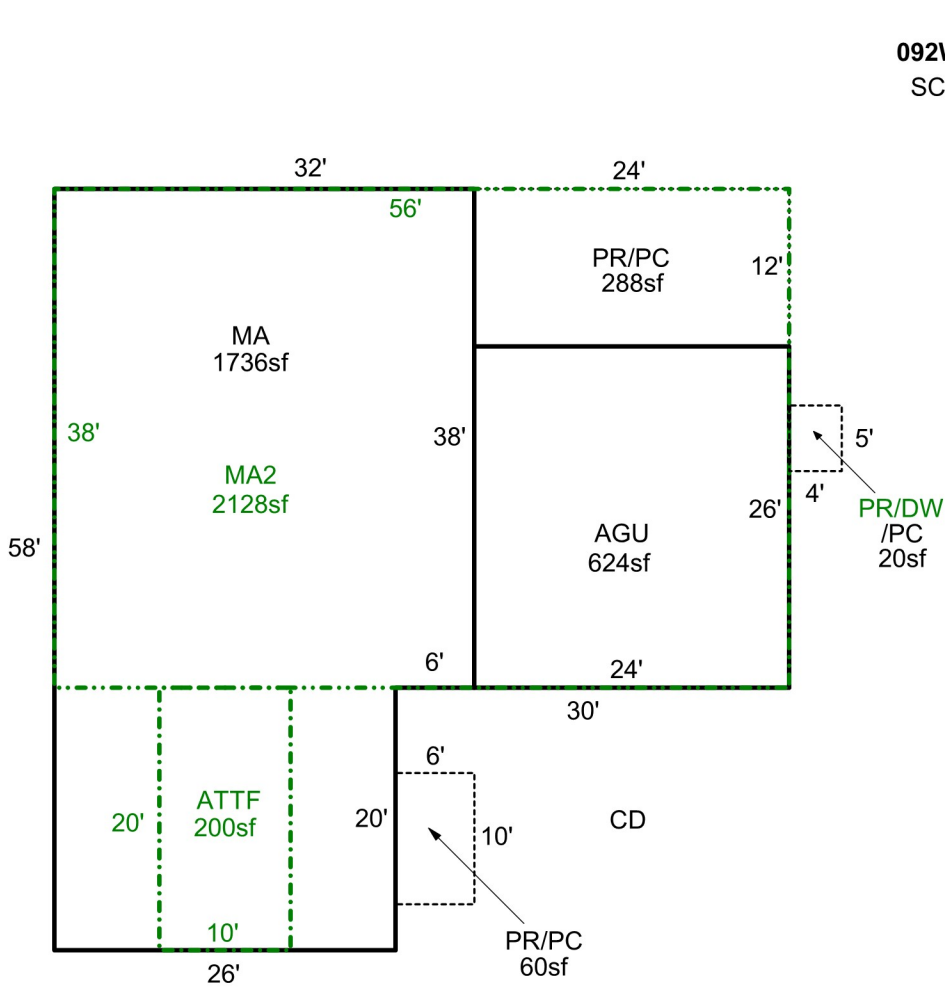

Sketch by Apex Sketch

AREA CALCULATIONS SUMMARY

Code	Description	Factor	Net Size	Perimeter	Net Totals
GLA1	MA	1.0	1736.0	180.0	1736.0
GLA2	ATTF	1.0	200.0	60.0	
	MA2	1.0	2128.0	188.0	2328.0
GAR	AGU	1.0	624.0	100.0	624.0
P/P	PR/PC	1.0	288.0	72.0	
	/PC	1.0	20.0	18.0	
	PR/PC	1.0	60.0	32.0	368.0

COMMENT TABLE 1

DRAWN BY JRONDEMA 3/31/17
 UPDATED BY JRONDEMA 2/22/18
 UPDATED BY CJURAN 09/28/2023 23-005642 AD

COMMENT TABLE 2

COMMENT TABLE 3

Net LIVABLE cnt 3 (rounded) 4,064



2/16/2018



2/16/2018