

Acct ID: 559178 MTL: 092E18DA01200 Date: 8-7-24 Appr: Gene Prop Class: 400 401 RMV Prop Class: 400  
Situs: 11673 RIVERWOOD DR SE LYONS OR 97358 MaSaNh: 01 06 007 Unit: 125279 Year: 2024

Last Date Appraised: 04/14/2021 Appraiser: CLINT LUKE Retag: Y N Tag info: \_\_\_\_\_  
Owner: RABE, JAMES D Roll Type: R  
cycle Tag Sales Verification Other: \_\_\_\_\_ Inspection level: 1 2 3 4 LCB TTO INSP AV: 144210  
RMV Land: 233270 RMV Imp: 0 RMV Total: 233270 MAV: 144210 MSAV: 0 SAV: 0  
Comment: LEVEL 4 4.14.21 WV06//

INPUT  
8-7-24  
Gene

ADD 2 HC'S BACK ON ACCT

TAKEN OFF BY MISTAKE DURING DAPT

Notations

No notation data available.

OSDs

No OSD data available.

Land

Site: 1 Code Area: 29544 Size: 1.26 Acres Use Code: 004 Zone: NREST SAV Use: Exception: 0  
Class: Value Source: Rural at MKT Description: RMV: 233270 Exception: Y N  
Adjustment(s): H2OGR Fire Patrol: SA004 Description: FIRE PATROL  
Comments: 21-22: PER #06 DEL ALL IMPS, OSD// 2009-2010 CYCLE WORK #36 CHANGED YI'S TO YI4G//

Improvements - Residence / Manufactured Structures

No residence or manufactured structure improvement data available.

+ HC 5 12824 AVE / 2012 X 2

Improvements - Accessory Buildings

No improvement data available for all other stat class types.

Apex

Noah's ~~Savannah~~ River

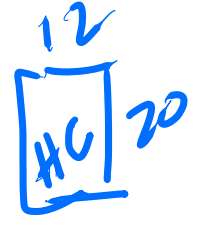

CYCLE 23  
8-7-24  
Gene

# SKETCH/AREA TABLE ADDENDUM

## SUBJECT INFO

File No.: 559178 Parcel No.: 092E18DA 01200  
 Property Address: 11673 RIVERWOOD DR SE  
 City: LYONS County: Marion State: OR ZipCode: 97358  
 Owner:  
 Client: Client Address:  
 Appraiser Name: Inspection Date:

## SKETCH

**559178**  
**092E18DA 01200**  
 SCALE=1:30

NORTH SANTIAM RIVER

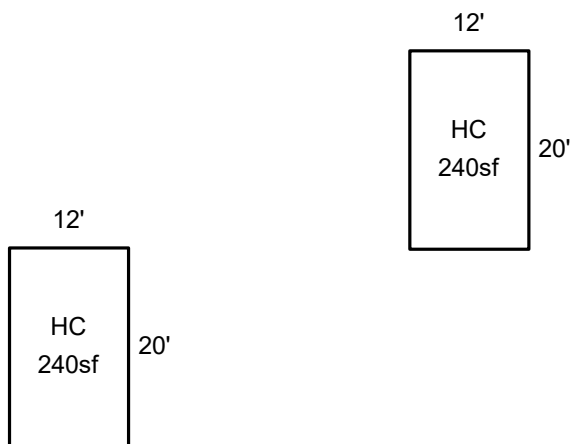

Sketch by ApexSketch

| AREA CALCULATIONS SUMMARY   |             |        |          |           |            | COMMENT TABLE 1  |  |
|---|-------------|--------|----------|-----------|------------|--|--|
| Code  | Description | Factor | Net Size | Perimeter | Net Totals |  |  |
| GBA1  | HC          | 1.0    | 240.0    | 64.0      |            | APEX BY CE 11/26/08<br>UPDATED BY JRONDEMA 11/14/18<br>UPDATED BY CJURAN 06/29/2021<br>UPDATED BY CLOBERG 08/21/24 |  |
|   | HC          | 1.0    | 240.0    | 64.0      | 480.0      |  |  |
| <p style="text-align: center;">Net BUILDING      cnt      2      (rounded)      480</p> |             |        |          |           |            |  |  |



8/7/24