

Acct ID: 556106 MTL: 062W03C000700 Date: **7.3.24** Appr: **JJS** Prop Class: 551 RMV Prop Class: 551  
 Situs: 10955 PORTLAND RD NE SALEM OR 97305 MaSaNh: 02 06 000 Unit: 100679 Year: 2024

Last Date Appraised: 04/14/2020 Appraiser: JORDAN SCHULTZ Retag: **N** Tag info: \_\_\_\_\_  
 Owner: KUZMIN, GEORGE & KUZMIN, IVAN & Roll Type: R

**Cycle** Tag Sales Verification Other: \_\_\_\_\_ Inspection level: 1 2 **3** 4 LCB TTO INSP AV: 109552  
 RMV Land: 260320 RMV Imp: 122620 RMV Total: 382940 MAV: 83500 MSAV: 26052 SAV: 48640

Comment:

**Upd Inv Input, JJS, 7.10.24**

Notations

RP/MS	Code	Description
RP	ZONED	FARM EFU ZONED

OSDs

Count	Code	Description	RMV	Code Area	Exception
1	SAA	SA OSD - AVERAGE	45000	01600	0

Land

Site: 1	Code Area: 01600	Size: 1.00 Acres	Use Code: 005	Zone: REST	SAV Use: 011	Exception: 0
Class:	Value Source: Farm Homesite	Description:			RMV: 20010	Exception: Y N
Adjustment(s):	GSOIL	Fire Patrol:		Description:		
Comments:	Liability year - 2009 / 100030					
Site: 2	Code Area: 01600	Size: 1.40 Acres	Use Code: 005	Zone: REST	SAV Use: 011	Exception: 0
Class: 4BD	Value Source: Farm Use - EFU	Description: FOUR BENCH DRY			RMV: 28020	Exception: Y N
Adjustment(s):	GSOIL	Fire Patrol:		Description:		
Comments:	Liability year - 1976 / 100030					
Site: 3	Code Area: 01600	Size: 7.60 Acres	Use Code: 005	Zone: REST	SAV Use: 011	Exception: 0
Class: 2BD	Value Source: Farm Use - EFU	Description: TWO BENCH DRY			RMV: 167290	Exception: Y N
Adjustment(s):	GSOIL	Fire Patrol:		Description:		
Comments:	Liability year - 1976					

Improvements - Residence / Manufactured Structures

Bldg: 1	Code Area: 01600	Stat Class: 131	Year Blt: 1950	Eff Year Blt: <b>1970</b>	Sq.Ft: 993	% Complete: 100
Desc: One Story Only				Dimensions:	RMV: 112120	
Func Obsc: 100	Econ %: 100	Other %: 100	Exception: 0	Adjust:	Adjust RMV: 0	

Floors

Type	Class	Display Group	Floor Size	Beds	Baths	Yr Blt	Eff Yr Blt	Inventory	Exception
First Floor	3	Finished	993	2	FB-1	1950	1950	KIT-, HVAC, FP - 1, ROOF, BATH - 1	Y N
Garage Attached	3	Unfinished	422	0	0	1950	1950	ROOF	Y N

Accessories

Description	Class	Size SqFt	Eff Yr Blt	RMV	Quantity	Exception
DECK	3	35	1950	516	1	Y N
DECK	3	64	1950	943	1	Y N
DECK	3	65	1950	958	1	Y N
ROOF EXTENSION OR PATIO COVER	3	35	1950	680	1	Y N
ROOF EXTENSION OR PATIO COVER	3	64	1950	1244	1	Y N
ROOF EXTENSION OR PATIO COVER	3	65	1950	1263	1	Y N

Improvements - Accessory Buildings

Bldg: 2	Code Area: 01600	Stat Class: 341	Year Blt: 1989	Eff Year Blt: 1989	Sq.Ft: 128	% Complete: 100
Desc: Multi Purpose Shed (MP)				Dimensions: 16x8	RMV: 1190	
Func Obsc: 100	Econ %: 100	Other %: 100	Exception: 0	Adjust:	Adjust RMV: 0	

Floors

Type	Class	Display Group	Floor Size	Beds	Baths	Yr Blt	Eff Yr Blt	Inventory	Exception
Multi-Purpose Bldg	5	Finished	128	0	0	1989	1989	FAIR	Y N

Accessories

Description	Class	Size SqFt	Eff Yr Blt	RMV	Quantity
No accessory data available					

Bldg: 3	Code Area: 01600	Stat Class: 351	Year Blt: 1989	Eff Year Blt: 1989	Sq.Ft: 504	% Complete: 100
Desc: General Purpose Building (GB)				Dimensions: 28x18	RMV: 3280	

Func Obsc: 100 Econ %: 100 Other %: 100 Exception: 0 Adjust: Adjust RMV: 0

**Floors**

Type	Class	Display Group	Floor Size	Beds	Baths	Yr Blt	Eff Yr Blt	Inventory	Exception: Y N
General Purpose Bldg	5	Finished	504	0	0	1989	1989	F	

**Accessories**

Description	Class	Size SqFt	Eff Yr Blt	RMV	Quantity
No accessory data available					

Bldg: 4 Code Area: 01600 Stat Class: 355 Year Blt: 1989 Eff Year Blt: 1989 Sq.Ft: 1860 % Complete: 100  
 Desc: Lean-to Heavy (LTH) Dimensions: 62x30 RMV: 4820  
 Func Obsc: 100 Econ %: 100 Other %: 100 Exception: 0 Adjust: Adjust RMV: 0

**Floors**

Type	Class	Display Group	Floor Size	Beds	Baths	Yr Blt	Eff Yr Blt	Inventory	Exception: Y N
Lean-to Heavy Duty	4	Finished	1860	0	0	1989	1989	FAIR	

**Accessories**

Description	Class	Size SqFt	Eff Yr Blt	RMV	Quantity
No accessory data available					

Bldg: 5 Code Area: 01600 Stat Class: 355 Year Blt: 1989 Eff Year Blt: 1989 Sq.Ft: 560 % Complete: 100  
 Desc: Lean-to Heavy (LTH) Dimensions: 28x20 RMV: 1210  
 Func Obsc: 100 Econ %: 100 Other %: 100 Exception: 0 Adjust: Adjust RMV: 0

**Floors**

Type	Class	Display Group	Floor Size	Beds	Baths	Yr Blt	Eff Yr Blt	Inventory	Exception: Y N
Lean-to Heavy Duty	4	Finished	560	0	0	1989	1989		

**Accessories**

Description	Class	Size SqFt	Eff Yr Blt	RMV	Quantity
No accessory data available					

# SKETCH/AREA TABLE ADDENDUM

## SUBJECT INFO

File No.: R56106 Parcel No.: 062W03C 00700  
 Property Address: 10955 PORTLAND RD NE  
 City: SALEM County: State: OR ZipCode: 97305  
 Owner:  
 Client: Client Address:  
 Appraiser Name: Inspection Date:

## SKETCH

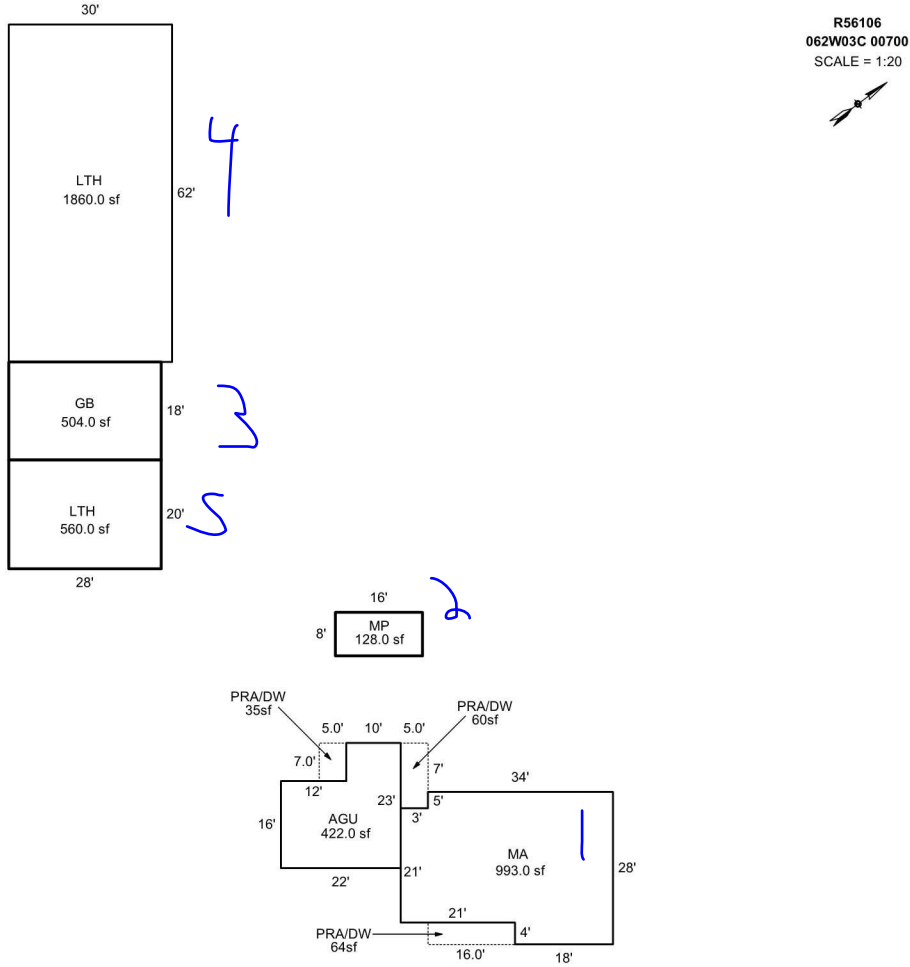

Sketch by Apex Sketch

### AREA CALCULATIONS SUMMARY

Code	Description	Factor	Net Size	Perimeter	Net Totals
GBA1	MP	1.0	128.0	48.0	
	LTH	1.0	1860.0	184.0	
	GB	1.0	504.0	92.0	
	LTH	1.0	560.0	96.0	3052.0
GLA1	MA	1.0	993.0	134.0	993.0
GAR	AGU	1.0	422.0	90.0	422.0
P/P	PRA/DW	1.0	35.0	24.0	
	PRA/DW	1.0	60.0	34.0	
	PRA/DW	1.0	64.0	40.0	159.0
	Net LIVABLE	cnt	1 (rounded)		993
	Net BUILDING	cnt	4 (rounded)		3,052

### COMMENT TABLE 1

DRAWN BY AC 5/21/10  
 UPDATED BY CJURAN 06/17/2021

### COMMENT TABLE 2

#10 CL 04/14/2020  
**JSS 7.3.24**

### COMMENT TABLE 3

CYCLE PICTOM C-19  
**Cycle L3**