

SKETCH/AREA TABLE ADDENDUM

SUBJECT INFO

File No.: 607181 Parcel No.: 062W32CD14700
 Property Address: 4825 FLAG AVE NE
 City: SALEM County: State: OR ZipCode:
 Owner:
 Client: Client Address:
 Appraiser Name: Inspection Date:

SKETCH

607181
062W32CD14700

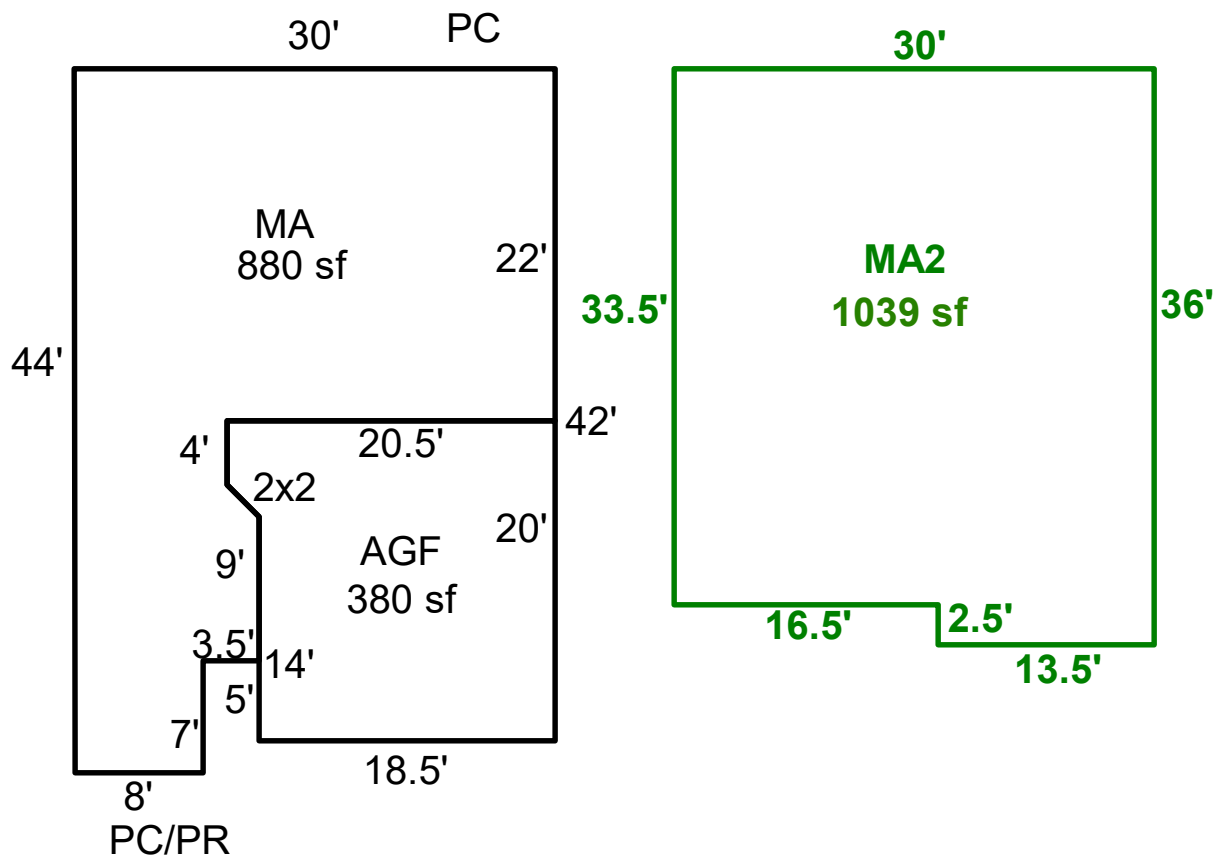

Sketch by ApexSketch

AREA CALCULATIONS SUMMARY

Code	Description	Factor	Net Size	Perimeter	Net Totals
GLA	MA	1.0	879.5	150.9	879.5
GLA2	MA2	1.0	1038.8	132.0	1038.8
GAR	AGF	1.0	380.0	79.8	380.0

COMMENT TABLE 1

DRAWN BY JT 3/28/24
Updated by AE 8.9.24

COMMENT TABLE 2

COMMENT TABLE 3

Net LIVABLE cnt 2 (rounded) 1,918