

# SKETCH/AREA TABLE ADDENDUM

## SUBJECT INFO

File No.: 607310 Parcel No.: 083W15CB07400  
 Property Address: 5627 Jeremy Valley Dr SE  
 City: Salem County: State: OR ZipCode: 97306  
 Owner:  
 Client: Client Address:  
 Appraiser Name: Inspection Date:

## SKETCH

**607310**

**083W15CB07400**

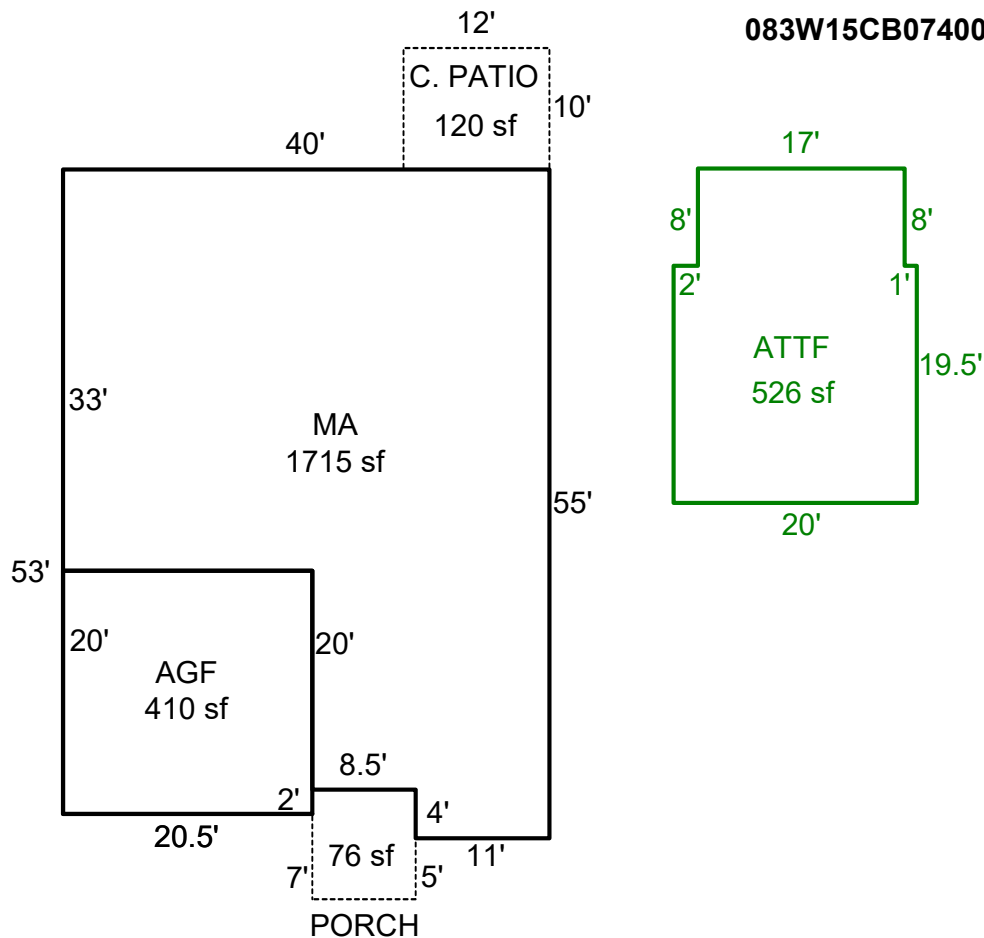

Sketch by ApexSketch

### AREA CALCULATIONS SUMMARY

Code	Description	Factor	Net Size	Perimeter	Net Totals
GLA	MA	1.0	1715.0	190.0	1715.0
GLA2	ATTF	1.0	526.0	95.0	526.0
GAR	AGF	1.0	410.0	81.0	410.0
P/P	PORCH	1.0	76.5	35.0	
	C. PATIO	1.0	120.0	44.0	196.5

### COMMENT TABLE 1

Drawn by AEIwood 8.6.24

### COMMENT TABLE 2

### COMMENT TABLE 3

Net LIVABLE                      cnt                      2      (rounded)                      2,241