

Acct ID: 536491 MTL: 093W250000100 Date: 12/13/23 Appr: MDL Prop Class: 451 RMV Prop Class: 451
 Situs: 3496 WINTERCREEK RD SE JEFFERSON OR 97352 MaSaNh: 07 06 000 Unit: 68639 Year: 2024

Last Date Appraised: 04/26/2021 Appraiser: MATT LORD Retag: Y N Tag info: 2024 - Tags/Permit (Addition)

Owner: STELLMACHER, WILLIAM J Roll Type: R

Cycle: Tag Sales Verification Other: _____ Inspection level: 1 2 3 4 LCB TTO INSP AV: 222360

RMV Land: 216500 RMV Imp: 237800 RMV Total: 454300 MAV: 222360 MSAV: 0 SAV: 0

Comment: LEVEL 4 4.26.21 CL10 23-003414 ADD MASTER BATH and enlarge Kitchen

Notations NO start ✓ 11/25

No notation data available.

OSDs

Count	Code	Description	RMV	Code Area	Exception
1	MKTA	OSD - AVERAGE	45000	14530	0

Land

Site: 1 Code Area: 14530 Size: 1.00 Acres Use Code: 005 Zone: REST SAV Use: Exception: 0
 Class: 6B Value Source: Rural Restrictive Description: SIX BENCH RMV: 171500 Exception: Y N
 Adjustment(s): VWFR, FSOIL Fire Patrol: Description:
 Comments: 19-20: CYCLE WORK #24 ADD VIEW ADJ// 03-04: REAPPRAISAL

Improvements - Residence / Manufactured Structures

Bldg: 1 Code Area: 14530 Stat Class: 131 + Year Blt: 1966 Eff Year Blt: 1994 Sq.Ft: 1234 % Complete: 100
 Desc: One Story Only Dimensions: RMV: 189940
 Func Obsc: 100 Econ %: 100 Other %: 100 Exception: 0 Adjust: Adjust RMV: 0

Floors

Type	Class	Display Group	Floor Size	Beds	Baths	Yr Blt	Eff Yr Blt	Inventory	Exception
First Floor	3 +	Finished	1234	2	FB-1	1966	1994	ROOF, HVAC, BATH - 1, FP, KIT	Y N
Garage Attached	3	Finished	528	0	0	1966	1994	ROOF	Y N

Accessories

Description	Class	Size SqFt	Eff Yr Blt	RMV	Quantity	Exception
YARD IMPROVEMENTS AVERAGE	3	0	1994	14396	1	Y N

Improvements - Accessory Buildings

Bldg: 2 Code Area: 14530 Stat Class: 351 Year Blt: 1997 Eff Year Blt: 2009 Sq.Ft: 2768 % Complete: 100
 Desc: General Purpose Building (GB) Dimensions: RMV: 47860
 Func Obsc: 100 Econ %: 100 Other %: 100 Exception: 0 Adjust: Adjust RMV: 0

Floors

Type	Class	Display Group	Floor Size	Beds	Baths	Yr Blt	Eff Yr Blt	Inventory	Exception
General Purpose Bldg	6	Finished	2768	0	0	1997	2009	FAIR	Y N

Accessories

Description	Class	Size SqFt	Eff Yr Blt	RMV	Quantity
No accessory data available					

SKETCH/AREA TABLE ADDENDUM

SUBJECT INFO

File No.: R36491 Parcel No.: 093W25 00100
 Property Address: 3496 WINTERCREEK RD SE
 City: JEFFERSON County: MARION State: OR ZipCode: 97352
 Owner:
 Client: Client Address:
 Appraiser Name: Inspection Date:

SKETCH

R36491
093W25 00100
SCALE=1:30

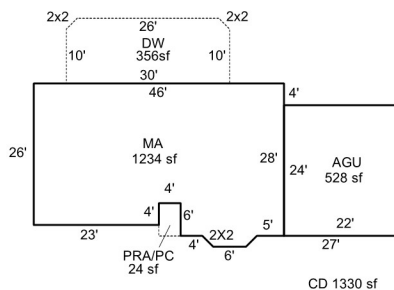
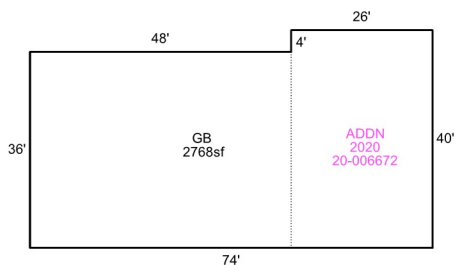

Sketch by Apex Sketch

AREA CALCULATIONS SUMMARY

Code	Description	Factor	Net Size	Perimeter	Net Totals
GBA1	GB	1.0	0.0	158.0	
	GB	1.0	2768.0	228.0	2768.0
GLA1	MA	1.0	1234.0	157.7	1234.0
GAR	AGU	1.0	528.0	92.0	528.0
P/P	PRA/PC	1.0	24.0	20.0	
	DW	1.0	356.0	81.7	380.0
	Net LIVABLE	cnt	1 (rounded)		1,234
	Net BUILDING	cnt	2 (rounded)		2,768

COMMENT TABLE 1

DRAWN BY JRONDEMA 9/21/18
 UPDATED BY CJURAN 12/15/2020 555-20-006672
 UPDATED BY CJURAN 06/010/2021

COMMENT TABLE 2

#10 CL 04/26/2021

COMMENT TABLE 3

TAGS L4

SKETCH/AREA TABLE ADDENDUM

SUBJECT INFO

File No.: 536491 Parcel No.: 093W25 00100
 Property Address: 3496 WINTERCREEK RD SE
 City: JEFFERSON County: MARION State: OR ZipCode: 97352
 Owner:
 Client: Client Address:
 Appraiser Name: Inspection Date:

SKETCH

536491
093W25 00100
SCALE=1:35

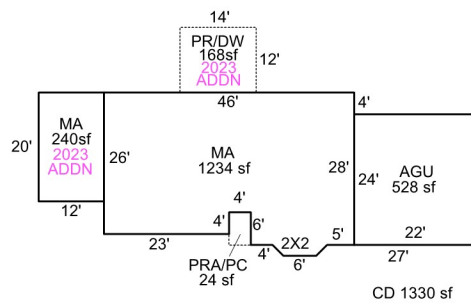
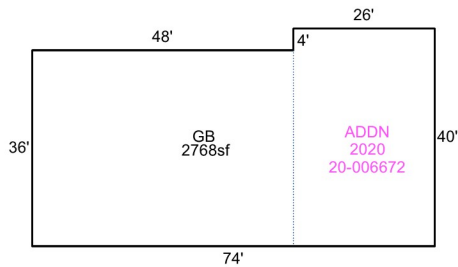

Sketch by Apex Sketch

AREA CALCULATIONS SUMMARY

Code	Description	Factor	Net Size	Perimeter	Net Totals
GBA1	GB	1.0	0.0	158.0	
	GB	1.0	2768.0	228.0	2768.0
GLA1	MA	1.0	1234.0	157.7	
	MA	1.0	240.0	64.0	1474.0
GAR	AGU	1.0	528.0	92.0	528.0
P/P	PRA/PC	1.0	24.0	20.0	
	PR/DW	1.0	168.0	52.0	192.0

COMMENT TABLE 1

DRAWN BY JRONDEMA 9/21/18
 UPDATED BY CJURAN 12/15/2020 555-20-006672
 UPDATED BY CJURAN 06/10/2021
 UPDATED BY CJURAN 10/31/2023 23-003414 AD

COMMENT TABLE 2

#10 CL 04/26/2021

MNL 12/13/23

COMMENT TABLE 3

TAGS L4

TAGS 103

Net LIVABLE	cnt	2	(rounded)	1,474
Net BUILDING	cnt	2	(rounded)	2,768

R36491
093W25 00100
SCALE=1:30

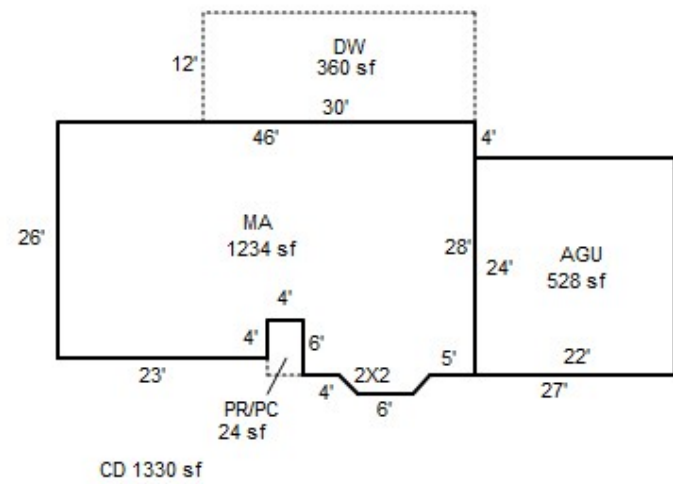
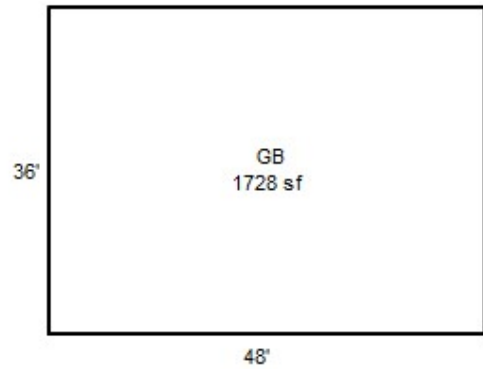

SKETCH/AREA TABLE ADDENDUM

SUBJECT INFO

File No.: R36491 Parcel No.: 093W25 00100
 Property Address: 3496 WINTERCREEK RD SE
 City: JEFFERSON County: MARION State: OR ZipCode: 97352
 Owner:
 Client: Client Address:
 Appraiser Name: Inspection Date:

SKETCH

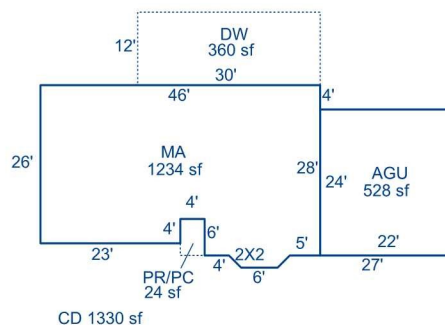
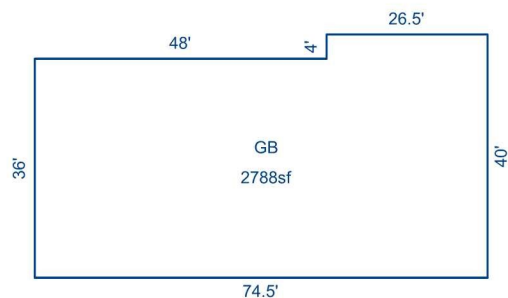

R36491
093W25 00100
 SCALE=1:30

Sketch by Apex Sketch

AREA CALCULATIONS SUMMARY

Code	Description	Factor	Net Size	Perimeter	Net Totals
GBA1	GB	1.0	0.0	158.5	
	GB	1.0	2788.0	229.0	2788.0
GLA1	MA	1.0	1234.0	157.7	1234.0
GAR	AGU	1.0	528.0	92.0	528.0
P/P	DW	1.0	360.0	84.0	
	PR/PC	1.0	24.0	20.0	384.0

COMMENT TABLE 1

DRAWN BY JRONDEMA 9/21/18
 UPDATED BY CJURAN 12/15/2020 555-20-006672

COMMENT TABLE 2

COMMENT TABLE 3

Net LIVABLE	cnt	1	(rounded)		1,234
Net BUILDING	cnt	2	(rounded)		2,788



R36491
GB

9/14/18



R36491
MA BACK

9/14/18



R36491
MA, AGU

9/14/18



R36491
VIEW

9/14/18





