

Acct ID: 353730 MTL: 102W080000402 Date: 12/13/23 Appr: MDL Prop Class: 451 RMV Prop Class: 451
 Situs: 4520 HAVEN LN SE JEFFERSON OR 97352 MaSaNh: 07 06 000 Unit: 85954 Year: 2023

Last Date Appraised: 09/28/2020 Appraiser: MATT LORD Retag: Y N Tag info: 2024 - Tags/Permit (Addition)

Owner: MILLESON-TAGHON TR & Roll Type: R

Cycle Tag Sales Verification Other: _____ Inspection level: 1 2 3 4 LCB TTO INSP AV: 255120

RMV Land: 180060 RMV Imp: 359880 RMV Total: 539940 MAV: 255120 MSAV: 0 SAV: 0

Comment: LEVEL 2 9.28.20 MH31//

Notations 23-24 12x36 addition to LB (23-004122) 100% complete

OSDs

Count	Code	Description	RMV	Code Area	Exception
1	MKTF	OSD - FAIR	35000	05530	0

Land

Site: 1	Code Area: 05530	Size: 0.25 Acres	Use Code: 005	Zone: REST	SAV Use:	Exception: 0
Class: 2BI	Value Source: Rural Restrictive	Description: TWO BENCH IRR			RMV: 29010	Exception: Y N
Adjustment(s):	IRR, GSOIL		Fire Patrol:		Description:	
Comments:	18-19: DISQ FARM USE					
Site: 2	Code Area: 05530	Size: 1.00 Acres	Use Code: 005	Zone: REST	SAV Use:	Exception: 0
Class: 2BI	Value Source: Rural Restrictive	Description: TWO BENCH IRR			RMV: 116050	Exception: Y N
Adjustment(s):	IRR, GSOIL		Fire Patrol:		Description:	
Comments:						

Improvements - Residence / Manufactured Structures

Bldg: 1	Code Area: 05530	Stat Class: 141	Year Blt: 2017	Eff Year Blt: 2017	Sq.Ft: 1266	% Complete: 100
Desc: One Story Only					Dimensions:	RMV: 326240
Func Obsc: 100	Econ %: 100	Other %: 100	Exception: 0	Adjust:	Adjust RMV: 0	

Floors

Type	Class	Display Group	Floor Size	Beds	Baths	Yr Blt	Eff Yr Blt	Inventory	Exception
First Floor	4	Finished	1266	2	FB-2	2017	2017	BATH - 2, KIT, HVAC+, ROOF	Y N
Garage Attached	4	Finished	576	0	0	2017	2017	ROOF	Y N

Accessories

Description	Class	Size SqFt	Eff Yr Blt	RMV	Quantity	Exception
CONCRETE DRIVEWAY	4	576	2017	1835	1	Y N
PATIO	4	376	2017	2027	1	Y N
PATIO	4	576	2017	3105	1	Y N
ROOF EXTENSION OR PATIO COVER	4	355	2017	10089	1	Y N

Improvements - Accessory Buildings

Bldg: 2	Code Area: 05530	Stat Class: 341	Year Blt: 2017	Eff Year Blt: 2017	Sq.Ft: 200	% Complete: 100
Desc: Multi Purpose Shed (MP)					Dimensions: 20x10	RMV: 10270
Func Obsc: 100	Econ %: 100	Other %: 100	Exception: 0	Adjust:	Adjust RMV: 0	

Floors

Type	Class	Display Group	Floor Size	Beds	Baths	Yr Blt	Eff Yr Blt	Inventory	Exception
Multi-Purpose Bldg	6	Finished	200	0	0	2017	2017	FAIR	Y N

Accessories

Description	Class	Size SqFt	Eff Yr Blt	RMV	Quantity
No accessory data available					

Bldg: 3	Code Area: 05530	Stat Class: 351	Year Blt: 2020	Eff Year Blt: 2020	Sq.Ft: 864	% Complete: 100
Desc: General Purpose Building (GB)					Dimensions: 36x24	RMV: 23370
Func Obsc: 100	Econ %: 100	Other %: 100	Exception: 0	Adjust:	Adjust RMV: 0	

Floors

Type	Class	Display Group	Floor Size	Beds	Baths	Yr Blt	Eff Yr Blt	Inventory	Exception
General Purpose Bldg	5	Finished	864	0	0	2020	2020	FAIR	Y N

Accessories

Description	Class	Size SqFt	Eff Yr Blt	RMV	Quantity
No accessory data available					

ACCOUNT # 353730 DATE: 12/13/23 RMV CLASS _____ PROP CLASS _____
 MTL 102W @ 402 APPR _____ TAG Y N _____
 COMMENTS: _____

RESIDENCE / MANUFACTURED STRUCTURES

ACCESSORY IMPROVEMENTS / OUTBUILDINGS

STAT _____ QLTY + - FLOOR _____
 AREA _____ EFF AREA _____ BED _____
 ROOF + HVAC +
 BATH PKG: _____ BATH _____ BATH + _____ 1/2 BTH
 FIREPLACE: _____
 KITCHEN - +
 YR BLT _____ EFF YR _____ ECON _____
 % COMP _____ % GOOD _____ FUNC _____
 EXCEPT Y N LUMP SUM: _____
 MISC: _____
 YI CLASS _____ F G A E
 SKIRT + LIN FT _____
 COMMENT: _____

TYPE GB
 STAT / CLASS S
 SIZE 432
 FAIR
 AVERAGE
 GOOD
 EXCELLENT
 BATH _____
 YR BLT 2023
 EFF YR 2023
 % COMP _____
 EXCEPT Y N
 MISC: _____
 COMMENT: _____

TYPE _____
 STAT / CLASS _____
 SIZE _____
 FAIR
 AVERAGE
 GOOD
 EXCELLENT
 BATH _____
 YR BLT _____
 EFF YR _____
 % COMP _____
 EXCEPT Y N
 MISC: _____
 COMMENT: _____

STAT _____ QLTY + - FLOOR _____
 AREA _____ EFF AREA _____ BED _____
 ROOF + HVAC +
 BATH PKG: _____ BATH _____ BATH + _____ 1/2 BTH
 FIREPLACE: _____
 KITCHEN - +
 YR BLT _____ EFF YR _____ ECON _____
 % COMP _____ % GOOD _____ FUNC _____
 EXCEPT Y N LUMP SUM: _____
 MISC: _____
 YI CLASS _____ F G A E
 SKIRT + LIN FT _____
 COMMENT: _____

TYPE _____
 STAT / CLASS _____
 SIZE _____
 FAIR
 AVERAGE
 GOOD
 EXCELLENT
 BATH _____
 YR BLT _____
 EFF YR _____
 % COMP _____
 EXCEPT Y N
 MISC: _____
 COMMENT: _____

TYPE _____
 STAT / CLASS _____
 SIZE _____
 FAIR
 AVERAGE
 GOOD
 EXCELLENT
 BATH _____
 YR BLT _____
 EFF YR _____
 % COMP _____
 EXCEPT Y N
 MISC: _____
 COMMENT: _____

STAT _____ QLTY + - FLOOR _____
 AREA _____ EFF AREA _____ BED _____
 ROOF + HVAC +
 BATH PKG: _____ BATH _____ BATH + _____ 1/2 BTH
 FIREPLACE: _____
 KITCHEN - +
 YR BLT _____ EFF YR _____ ECON _____
 % COMP _____ % GOOD _____ FUNC _____
 EXCEPT Y N LUMP SUM: _____
 MISC: _____
 YI CLASS _____ F G A E
 SKIRT + LIN FT _____
 COMMENT: _____

TYPE _____
 STAT / CLASS _____
 SIZE _____
 FAIR
 AVERAGE
 GOOD
 EXCELLENT
 BATH _____
 YR BLT _____
 EFF YR _____
 % COMP _____
 EXCEPT Y N
 MISC: _____
 COMMENT: _____

TYPE _____
 STAT / CLASS _____
 SIZE _____
 FAIR
 AVERAGE
 GOOD
 EXCELLENT
 BATH _____
 YR BLT _____
 EFF YR _____
 % COMP _____
 EXCEPT Y N
 MISC: _____
 COMMENT: _____

Addition

SKETCH/AREA TABLE ADDENDUM

SUBJECT INFO

File No.: 353730 Parcel No.: 102W08 00402
 Property Address: 4520 HAVEN LANE SE
 City: JEFFERSON County: MARION State: OR ZipCode: 97352
 Owner:
 Client: Client Address:
 Appraiser Name: Inspection Date:

SKETCH

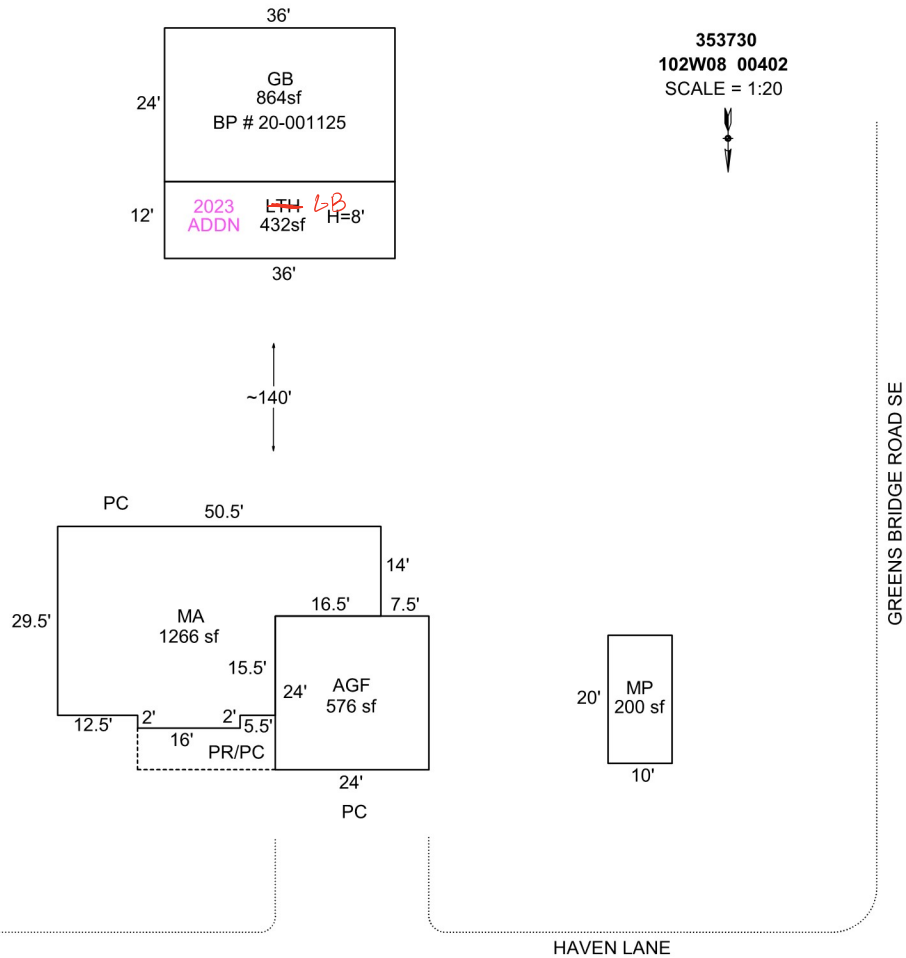

Sketch by Apex Sketch

AREA CALCULATIONS SUMMARY

Code	Description	Factor	Net Size	Perimeter	Net Totals
GBA1	MP	1.0	200.0	60.0	
	GB	1.0	864.0	120.0	
	LTH	1.0	432.0	96.0	1496.0
GLA1	MA	1.0	1266.0	164.0	1266.0
GAR	AGF	1.0	576.0	96.0	576.0

COMMENT TABLE 1

DRAWN BY JRONDEMA 12/5/16
 UPDATED BY JRONDEMA 1/3/18
 UPDATED BY JRONDEMA 1/10/18
 UPD BY PHU 06.11.20 / BP # 20-001125
 UPDATED BY CJURAN 07/25/2023 555-23-004122

COMMENT TABLE 2

MA 1/3/23

COMMENT TABLE 3

TAB L2

Net LIVABLE	cnt	1	(rounded)	1,266
Net BUILDING	cnt	3	(rounded)	1,496



R353730

MA BACK

12-22-17



R353730

MA, AGF

12-22-17



R353730

MP

12-22-17



1/3/24