

Acct ID: 330715 MTL: 084W12D004100 Date: 1-9-24 Appr: WW Prop Class: 401 RMV Prop Class: 401
 Situs: 4095 SUNSET RIDGE RD S SALEM OR 97302 MaSaNh: 06 06 002 Unit: 55340 Year: 2024

Last Date Appraised: 08/11/2010 Appraiser: WENDY WILLIAMS Retag: Y N Tag info: 2024 - NEW CONSTRUCTION (Outbuilding)
 Owner: MICHAEL & MELANIE FREEMAN LT Roll Type: R
 Cycle: Tag Sales Verification Other: _____ Inspection level: 1 2 3 4 LCB TTO INSP AV: 861370
 RMV Land: 288480 RMV Imp: 1126400 RMV Total: 1414880 MAV: 861370 MSAV: 0 SAV: 0
 Comment:

Not enough started, Upd OSD, YI AND CLASS

23-007881 SHOP w/
 BATH ROOM & PLBG -
 NO LIVING
 FOUNDATION 10/25

Notations

No notation data available.

OSDs

Count	Code	Description	RMV	Code Area	Exception
1	MKTG	OSD - GOOD <i>jet</i>	55000	92430	0

Land

Site: 1 Code Area: 92430 Size: 2.14 Acres Use Code: 004 Zone: NREST SAV Use: Exception: 0
 Class: Value Source: Rural at MKT Description: RMV: 233480 Exception: Y N
 Adjustment(s): Fire Patrol: Description:
 Comments: 03-04: SOUTH RIDGE ESTATES SUBDIVISION MERGING INTO SURROUNDING AREA

Improvements - Residence / Manufactured Structures

Bldg: 1 Code Area: 92430 Stat Class: T72 - Year Blt: 2008 Eff Year Blt: 2008 Sq.Ft: 4825 % Complete: 100
 Desc: Multi Story above grade *MB2* CLASSING CALC Dimensions: RMV: 1126400
 Func Obsc: 100 Econ %: 100 Other %: 100 Exception: 0 Adjust: Adjust RMV: 0

Floors

Type	Class	Display Group	Floor Size	Beds	Baths	Yr Blt	Eff Yr Blt	Inventory	Exception
First Floor	<u>7</u> -	Finished	1938	1	FB-1/ HB-1	2008	2008	ROOF+, FP, HVAC+, BATH+, KIT+, BTH - 1, BATH - 1	Exception: Y N
Second Floor	<u>7</u> -	Finished	2887	3	FB-2	2008	2008	ROOF+, HVAC+, BATH - 2	Exception: Y N
Garage Attached	6	Finished	550	0	0	2008	2008	ROOF+	Exception: Y N
Garage Attached	6	Finished	480	0	0	2008	2008	ROOF+	Exception: Y N

Accessories

Description	Class	Size SqFt	Eff Yr Blt	RMV	Quantity	Exception
ENCLOSED PORCH	6	195	2008	12332	1	Exception: Y N
YARD IMPROVEMENTS GOOD <i>lxw</i>	6	1	2008	46547	1	Exception: Y <u>N</u>

Improvements - Accessory Buildings

No improvement data available for all other stat class types.



Spw owner
1/3/24 cement & 2 framed walls
only per her
photos.

SKETCH/AREA TABLE ADDENDUM

SUBJECT INFO

File No.: 330715 Parcel No.: 084W12D 04100
 Property Address: 4095 SUNSET RIDGE RD
 City: SALEM County: MARION State: OR ZipCode: 97302
 Owner:
 Client: Client Address:
 Appraiser Name: Inspection Date:

SKETCH

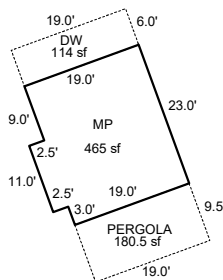

330715
084W12D 04100
SCALE = 1:30

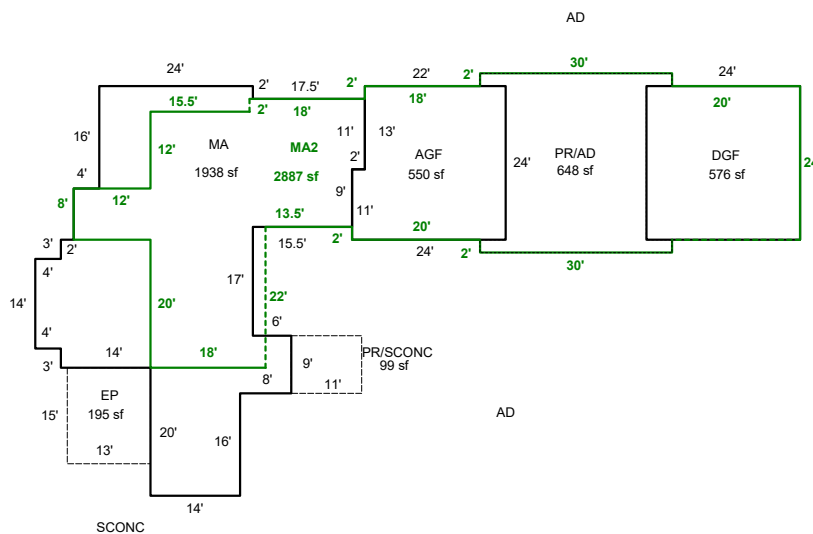

Sketch by ApexSketch

AREA CALCULATIONS SUMMARY

Code	Description	Factor	Net Size	Perimeter	Net Totals
GBA1	MP	1.0	465.0	89.0	465.0
GLA1	MA	1.0	1938.0	243.0	1938.0
GLA2	MA2	1.0	2887.0	327.0	2887.0
GAR	DGF	1.0	576.0	96.0	1126.0
	AGF	1.0	550.0	96.0	
P/P	EP	1.0	195.0	56.0	1236.5
	PR/SCONC	1.0	99.0	40.0	
	PR/AD	1.0	648.0	132.0	
	DW	1.0	114.0	50.0	
	PERGOLA	1.0	180.5	57.0	
	Net LIVABLE	cnt	2 (rounded)		4,825
	Net BUILDING	cnt	1 (rounded)		465

COMMENT TABLE 1

DRAWN BY SH 1-9-08
 UPDATED BY SH 11-3-08
 UPDATED BY CJURAN 11/21/2023 23-007881 MP

COMMENT TABLE 2

COMMENT TABLE 3