

Acct ID: 537299 MTL: 103W130000500 Date: 4.9.24 Appr: MDL Prop Class: 551 RMV Prop Class: 551
 Situs: 3080 JEFFERSON-SCIO DR SE JEFFERSON OR 97352 MaSaNh: 07 06 000 Unit: 89952 Year: 2024
 Last Date Appraised: 12/17/2022 Appraiser: MATT LORD Retag: Y (N) Tag info: 2024 - Tags/Permit (Completion)
 Owner: WELLS, LARRY WAYNE & WELLS, KAREN L Roll Type: R
 Cycle Tag Sales Verification Other: _____ Inspection level: 1 2 3 (4) LCB TTO INSP AV: 604945
 RMV Land: 519550 RMV Imp: 672050 RMV Total: 1191600 MAV: 422340 MSAV: 182605 SAV: 550178
 Comment: 23-24 L2 12/17/22 ML
 22-23: Cycle, MS #124483 n/c per MH#49, 8-9-21

Notations

N/c TAG Input 12/11/23

RP/MS	Code	Description
MS	ZONED	FARM EFU ZONED

OSDs

Count	Code	Description	RMV	Code Area	Exception
1	SAG	SA OSD - GOOD	55000	14530	0
1	SAN	SA OSD - NO LANDSCAPE	30000	14530	0

Land

Site: 2	Code Area: 14530	Size: 1.00 Acres	Use Code: 005	Zone: REST	SAV Use: 011	Exception: 0
Class: 2BISS	Value Source: Farm Homesite	Description: TWO BENCH IRR SOUTH SPECIAL	RMV: 3450	Exception: Y	N	
Adjustment(s):	GSOIL, IRR, WASTE	Fire Patrol:	Description:			
Comments:	Liability year - 2009 / 81400130					
Site: 3	Code Area: 14530	Size: 88.30 Acres	Use Code: 005	Zone: REST	SAV Use: 011	Exception: 0
Class: 2BISS	Value Source: Farm Use - EFU	Description: TWO BENCH IRR SOUTH SPECIAL	RMV: 318870	Exception: Y	N	
Adjustment(s):	GSOIL, IRR, WASTE	Fire Patrol:	Description:			
Comments:	Liability year - 1980 / 81400130					
Site: 4	Code Area: 14530	Size: 11.70 Acres	Use Code: 005	Zone: REST	SAV Use: 011	Exception: 0
Class: 4BISS	Value Source: Farm Use - EFU	Description: FOUR BENCH IRR SPECIAL SOUTH	RMV: 38580	Exception: Y	N	
Adjustment(s):	GSOIL, IRR, WASTE	Fire Patrol:	Description:			
Comments:	Liability year - 1985 / 81400130					
Site: 5	Code Area: 14530	Size: 11.88 Acres	Use Code: 005	Zone: REST	SAV Use: 011	Exception: 0
Class: WST	Value Source: WASTE RURAL	Description: Rural WASTELAND	RMV: 1120	Exception: Y	N	
Adjustment(s):	GSOIL, IRR, WASTE	Fire Patrol:	Description:			
Comments:	Liability year - 1980 Near North Santiam River					
Site: 6	Code Area: 14530	Size: 20.00 Acres	Use Code: 005	Zone: REST	SAV Use: 011	Exception: 0
Class: 2BISS	Value Source: Woodlot	Description: TWO BENCH IRR SOUTH SPECIAL	RMV: 69080	Exception: Y	N	
Adjustment(s):	GSOIL, IRR, WASTE	Fire Patrol:	Description:			
Comments:	Liability year - 1980					
Site: 7	Code Area: 14530	Size: 1.00 Acres	Use Code: 005	Zone: REST	SAV Use: 011	Exception: 0
Class: 2BISS	Value Source: Farm Homesite	Description: TWO BENCH IRR SOUTH SPECIAL	RMV: 3450	Exception: Y	N	
Adjustment(s):	GSOIL, IRR, WASTE	Fire Patrol:	Description:			
Comments:	Liability year - 2023 (taken from 2BI)					

Improvements - Residence / Manufactured Structures

Bldg: 1	Code Area: 14530	Stat Class: 443	Year Blt: 1971	Eff Year Blt: 1971	Sq.Ft: 672	% Complete: 100
Desc:	MANUF STRUCT, CLASS 4, 12' WIDE SINGLE		Dimensions: 56x12	RMV: 13770		
Func Obsc: 100	Econ %: 100	Other %: 100	Exception: 0	Adjust:	Adjust RMV: 0	

Floors

Type	Class	Display Group	Floor Size	Beds	Baths	Yr Blt	Eff Yr Blt	Inventory	Exception
First Floor	4	Finished	672	2	FB-1	1971	1971	KIT-, HVAC+, SKIRT, ROOF, BATH - 1	Y N

Accessories

Description	Class	Size SqFt	Eff Yr Blt	RMV	Quantity
No accessory data available					

Bldg: 10	Code Area: 14530	Stat Class: 144	Year Blt: 1920	Eff Year Blt: 1965	Sq.Ft: 3428	% Complete: 100
Desc:	Multi Story above grade with basement		Dimensions:	RMV: 418030		
Func Obsc: 100	Econ %: 100	Other %: 100	Exception: 0	Adjust:	Adjust RMV: 0	

Floors

Type	Class	Display Group	Floor Size	Beds	Baths	Yr Blt	Eff Yr Blt	Inventory	
First Floor	4	Finished	2096	1	FB-2	1920	1965	BATH - 2, FP - 2, HVAC, ROOF, KIT-	Exception: Y N
Attic	4	Finished	1332	4	HB-1	1920	1965	BTH - 1	Exception: Y N
Basement	4	Unfinished	1120	0	0	1920	1965		Exception: Y N
Garage Attached	4	Finished	484	0	0	1975	1975	ROOF	Exception: Y N

Accessories

Description	Class	Size SqFt	Eff Yr Blt	RMV	Quantity	
DECK	4	616	1965	8870	1	Exception: Y N
YARD IMPROVEMENTS GOOD	4	1	1965	26784	1	Exception: Y N

Bldg: 15 Code Area: 14530 Stat Class: 142 Year Blt: 2022 Eff Year Blt: 2022 Sq.Ft: 2227 % Complete: 50
 Desc: Multi Story above grade Dimensions: RMV: 186940
 Func Obsc: 100 Econ %: 100 Other %: 100 Exception: 0 Adjust: Adjust RMV: 0

Floors

Type	Class	Display Group	Floor Size	Beds	Baths	Yr Blt	Eff Yr Blt	Inventory	
First Floor	4	Finished	2227	2	FB-2	2022	2022	KIT, HVAC+, FP - 1, ROOF, BATH - 2	Exception: Y N
Attic	4	Unfinished	378	0	0	2022	2022		Exception: Y N
Garage Attached	4	Finished	621	0	0	2022	2022	ROOF	Exception: Y N

Accessories

Description	Class	Size SqFt	Eff Yr Blt	RMV	Quantity	
ROOF EXTENSION OR PATIO COVER	4	32	2022	464	0	Exception: Y N

Improvements - Accessory Buildings

Bldg: 1 Code Area: 14530 Stat Class: 351 Year Blt: 1985 Eff Year Blt: 1985 Sq.Ft: 800 % Complete: 100
 Desc: General Purpose Building (GB) Dimensions: RMV: 5480
 Func Obsc: 100 Econ %: 100 Other %: 100 Exception: 0 Adjust: Adjust RMV: 0

Floors

Type	Class	Display Group	Floor Size	Beds	Baths	Yr Blt	Eff Yr Blt	Inventory	
General Purpose Bldg	6	Finished	800	0	0	1985	1985	FAIR	Exception: Y N

Accessories

Description	Class	Size SqFt	Eff Yr Blt	RMV	Quantity	
No accessory data available						

Bldg: 3 Code Area: 14530 Stat Class: 312 Year Blt: 1985 Eff Year Blt: 2000 Sq.Ft: 1600 % Complete: 100
 Desc: Loft Barn (LB) Dimensions: 50x32 RMV: 14120
 Func Obsc: 50 Econ %: 100 Other %: 100 Exception: 0 Adjust: Adjust RMV: 0

Floors

Type	Class	Display Group	Floor Size	Beds	Baths	Yr Blt	Eff Yr Blt	Inventory	
Loft Barn	5	Finished	1600	0	0	1985	2000	FAIR	Exception: Y N

Accessories

Description	Class	Size SqFt	Eff Yr Blt	RMV	Quantity	
No accessory data available						

Bldg: 4 Code Area: 14530 Stat Class: 353 Year Blt: 1985 Eff Year Blt: 1985 Sq.Ft: 1472 % Complete: 100
 Desc: Machine Shed (MS) Dimensions: 46x32 RMV: 3710
 Func Obsc: 100 Econ %: 100 Other %: 100 Exception: 0 Adjust: Adjust RMV: 0

Floors

Type	Class	Display Group	Floor Size	Beds	Baths	Yr Blt	Eff Yr Blt	Inventory	
Machine Shed	4	Finished	1472	0	0	1985	1985	FAIR	Exception: Y N

Accessories

Description	Class	Size SqFt	Eff Yr Blt	RMV	Quantity	
No accessory data available						

Bldg: 5 Code Area: 14530 Stat Class: 353 Year Blt: 1985 Eff Year Blt: 1985 Sq.Ft: 1024 % Complete: 100
 Desc: Machine Shed (MS) Dimensions: 32x32 RMV: 2250
 Func Obsc: 100 Econ %: 100 Other %: 100 Exception: 0 Adjust: Adjust RMV: 0

Floors

Type	Class	Display Group	Floor Size	Beds	Baths	Yr Blt	Eff Yr Blt	Inventory	
Machine Shed	4	Finished	1024	0	0	1985	1985		Exception: Y N

Accessories									
Description		Class	Size SqFt	Eff Yr Blt	RMV	Quantity			
No accessory data available									
Bldg: 6	Code Area: 14530	Stat Class: 325	Year Blt:	Eff Year Blt:	Sq.Ft: 0	% Complete: 100			
Desc: Commercial Grain Storage (GR)					Dimensions:	RMV: 1000			
Func Obsc: 100	Econ %: 100	Other %: 100	Exception: 0		Adjust:	Adjust RMV: 0			
Floors									
Type	Class	Display Group	Floor Size	Beds	Baths	Yr Blt	Eff Yr Blt	Inventory	
Grain Bin	4	Finished	0	0	0	0	0	Exception: Y N	

Accessories									
Description		Class	Size SqFt	Eff Yr Blt	RMV	Quantity			
No accessory data available									
Bldg: 7	Code Area: 14530	Stat Class: 325	Year Blt:	Eff Year Blt:	Sq.Ft: 0	% Complete: 100			
Desc: Commercial Grain Storage (GR)					Dimensions:	RMV: 1000			
Func Obsc: 100	Econ %: 100	Other %: 100	Exception: 0		Adjust:	Adjust RMV: 0			
Floors									
Type	Class	Display Group	Floor Size	Beds	Baths	Yr Blt	Eff Yr Blt	Inventory	
Grain Bin	4	Finished	0	0	0	0	0	Exception: Y N	

Accessories									
Description		Class	Size SqFt	Eff Yr Blt	RMV	Quantity			
No accessory data available									
Bldg: 8	Code Area: 14530	Stat Class: 353	Year Blt: 1980	Eff Year Blt: 1980	Sq.Ft: 1920	% Complete: 100			
Desc: Machine Shed (MS)					Dimensions: 64x30	RMV: 5150			
Func Obsc: 100	Econ %: 100	Other %: 100	Exception: 0		Adjust:	Adjust RMV: 0			
Floors									
Type	Class	Display Group	Floor Size	Beds	Baths	Yr Blt	Eff Yr Blt	Inventory	
Machine Shed	5	Finished	1920	0	0	1980	1980	Exception: Y N	

Accessories									
Description		Class	Size SqFt	Eff Yr Blt	RMV	Quantity			
No accessory data available									
Bldg: 9	Code Area: 14530	Stat Class: 351	Year Blt: 1980	Eff Year Blt: 1980	Sq.Ft: 3040	% Complete: 100			
Desc: General Purpose Building (GB)					Dimensions: 76x40	RMV: 11950			
Func Obsc: 100	Econ %: 100	Other %: 100	Exception: 0		Adjust:	Adjust RMV: 0			
Floors									
Type	Class	Display Group	Floor Size	Beds	Baths	Yr Blt	Eff Yr Blt	Inventory	
General Purpose Bldg	5	Finished	3040	0	0	1980	1980	FAIR	

Accessories									
Description		Class	Size SqFt	Eff Yr Blt	RMV	Quantity			
No accessory data available									
Bldg: 11	Code Area: 14530	Stat Class: 341	Year Blt: 1985	Eff Year Blt: 1985	Sq.Ft: 432	% Complete: 100			
Desc: Multi Purpose Shed (MP)					Dimensions: 18x24	RMV: 2370			
Func Obsc: 100	Econ %: 100	Other %: 100	Exception: 0		Adjust:	Adjust RMV: 0			
Floors									
Type	Class	Display Group	Floor Size	Beds	Baths	Yr Blt	Eff Yr Blt	Inventory	
Multi-Purpose Bldg	5	Finished	432	0	0	1985	1985	FAIR	

Accessories									
Description		Class	Size SqFt	Eff Yr Blt	RMV	Quantity			
No accessory data available									
Bldg: 12	Code Area: 14530	Stat Class: 351	Year Blt: 1985	Eff Year Blt: 1985	Sq.Ft: 600	% Complete: 100			
Desc: General Purpose Building (GB)					Dimensions: 20x30	RMV: 3720			
Func Obsc: 100	Econ %: 100	Other %: 100	Exception: 0		Adjust:	Adjust RMV: 0			
Floors									
Type	Class	Display Group	Floor Size	Beds	Baths	Yr Blt	Eff Yr Blt	Inventory	
General Purpose Bldg	6	Finished	600	0	0	1985	1985	Exception: Y N	

Accessories									
No accessory data available									

Description		Class	Size SqFt	Eff Yr Blt	RMV	Quantity		
No accessory data available								
Bldg: 13	Code Area: 14530	Stat Class: 354	Year Blt: 1985	Eff Year Blt: 1985	Sq.Ft: 200	% Complete: 100		
Desc: Lean-to Light (LTL)				Dimensions: RMV: 190				
Func Obsc: 100	Econ %: 100	Other %: 100	Exception: 0	Adjust:	Adjust RMV: 0			
Floors								
Type	Class	Display Group	Floor Size	Beds	Baths	Yr Blt	Eff Yr Blt	Inventory
Lean-to Light Duty	6	Finished	200	0	0	1985	1985	Exception: Y N
Accessories								
Description		Class	Size SqFt	Eff Yr Blt	RMV	Quantity		
No accessory data available								
Bldg: 14	Code Area: 14530	Stat Class: 355	Year Blt: 1985	Eff Year Blt: 2000	Sq.Ft: 650	% Complete: 100		
Desc: Lean-to Heavy (LTH)				Dimensions: RMV: 2370				
Func Obsc: 100	Econ %: 100	Other %: 100	Exception: 0	Adjust:	Adjust RMV: 0			
Floors								
Type	Class	Display Group	Floor Size	Beds	Baths	Yr Blt	Eff Yr Blt	Inventory
Lean-to Heavy Duty	5	Finished	650	0	0	1985	2000	Exception: Y N
Accessories								
Description		Class	Size SqFt	Eff Yr Blt	RMV	Quantity		
No accessory data available								

SKETCH/AREA TABLE ADDENDUM

SUBJECT INFO

File No.: 537299 Parcel No.: 103W13 00500
 Property Address: 3080 JEFFERSON SCIO DRIVE SE
 City: JEFFERSON County: MARION State: OR ZipCode: 97352
 Owner:
 Client: Client Address:
 Appraiser Name: Inspection Date:

SKETCH

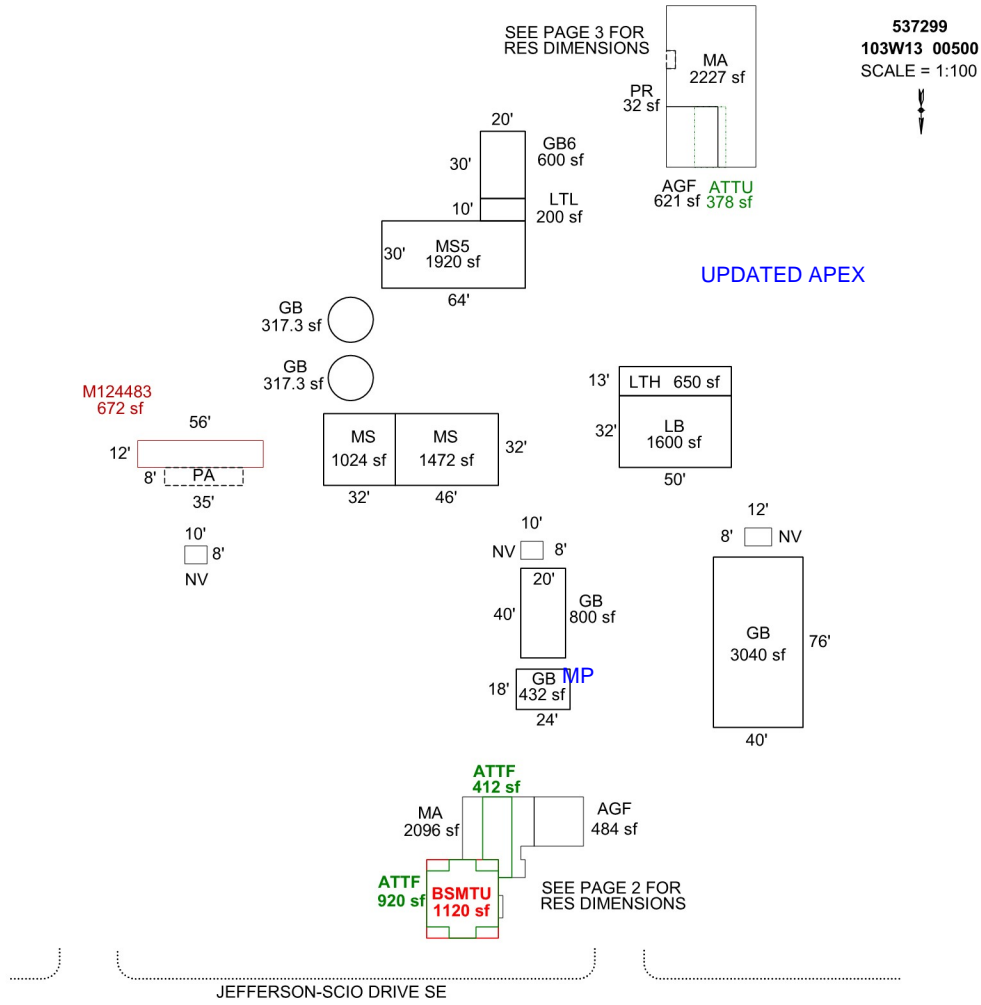

Sketch by Apex Sketch

AREA CALCULATIONS SUMMARY

Code	Description	Factor	Net Size	Perimeter	Net Totals	
GBA1	GB	1.0	317.3	63.1		
	LTH	1.0	650.0	126.0		
	GB6	1.0	600.0	100.0		
	LTL	1.0	200.0	60.0		
	GB	1.0	3040.0	232.0		
	GB	1.0	432.0	84.0		
	GB	1.0	800.0	120.0		
	MS5	1.0	1920.0	188.0		
	LB	1.0	1600.0	164.0		
	MS	1.0	1472.0	156.0		
	MS	1.0	1024.0	128.0		
	GB	1.0	317.3	63.1	12372.6	
	GLA1	MA	1.0	2096.0	230.0	
		ATTF	1.0	920.0	134.0	
GLA2	MA	1.0	2227.0	232.0	5243.0	
	ATTF	1.0	412.0	98.0		
	7 addl items					
	Net LIVABLE	cnt	5 (rounded)		6,033	
	Net BUILDING	cnt	12 (rounded)		12,373	

COMMENT TABLE 1

Apex by RW 04/16/08
 UPDATED BY CJURAN 04/18/2022 555-22-000087
 UPDATED BY CJURAN 03/22/2023

COMMENT TABLE 2

MDL 12/17/2023

COMMENT TABLE 3

TAGS L2

SKETCH/AREA TABLE ADDENDUM

SUBJECT INFO

File No.: 537299 Parcel No.: 103W13 00500
 Property Address: 3080 JEFFERSON SCIO DRIVE SE
 City: JEFFERSON County: MARION State: OR ZipCode: 97352
 Owner:
 Client:
 Client Address:
 Appraiser Name: Inspection Date:

SKETCH

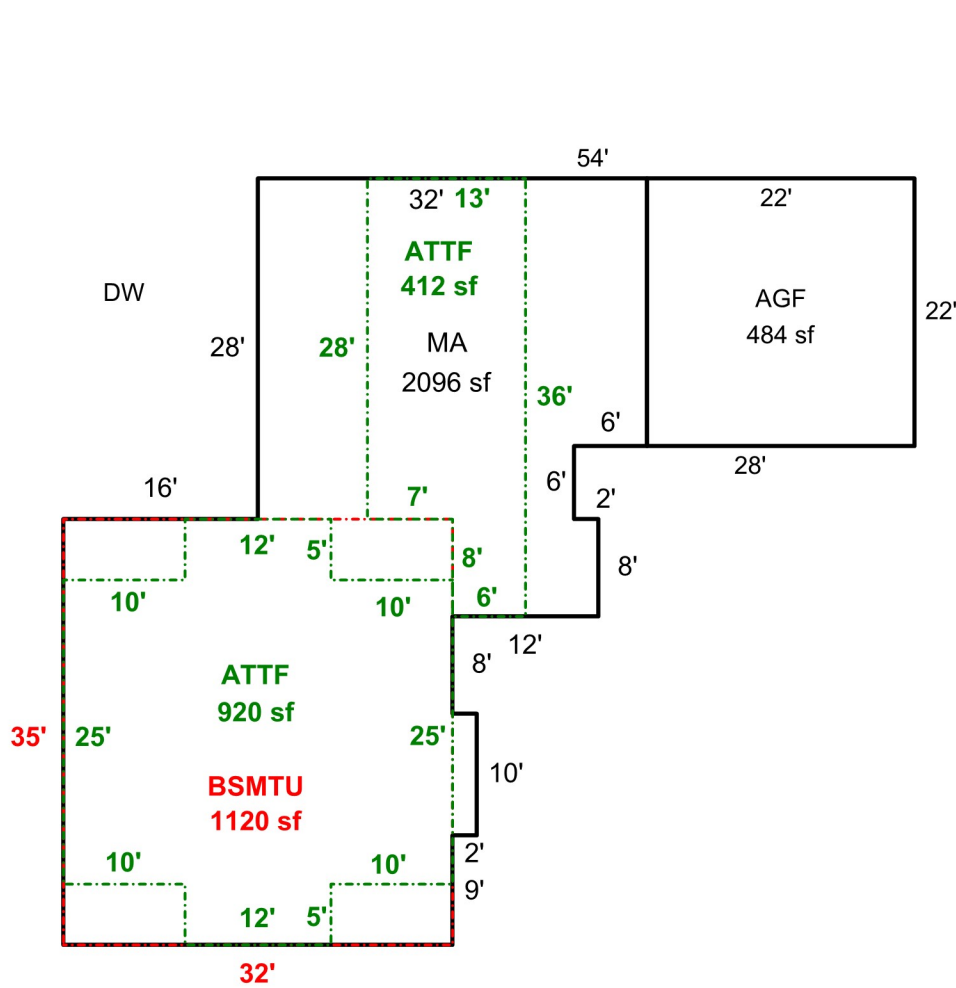

Sketch by Apex Sketch

AREA CALCULATIONS SUMMARY

Code	Description	Factor	Net Size	Perimeter	Net Totals
GLA1	MA	1.0	2096.0	230.0	
	ATTF	1.0	920.0	134.0	3016.0
GLA2	ATTF	1.0	412.0	98.0	412.0
BSMT	BSMTU	1.0	1120.0	134.0	1120.0
GAR	AGF	1.0	484.0	88.0	484.0

COMMENT TABLE 1

Apex by RW 04/16/08
 UPDATED BY CJURAN 04/18/2022 555-22-000087
 UPDATED BY CJURAN 03/22/2023

COMMENT TABLE 2

MDL 12/17/2023

COMMENT TABLE 3

TAGS L2

Net LIVABLE cnt 3 (rounded) 3,428

SKETCH/AREA TABLE ADDENDUM

SUBJECT INFO

File No.: 537299 Parcel No.: 103W13 00500
 Property Address: 3080 JEFFERSON SCIO DRIVE SE
 City: JEFFERSON County: MARION State: OR ZipCode: 97352
 Owner:
 Client: Client Address:
 Appraiser Name: Inspection Date:

SKETCH

537299
103W13 00500
 SCALE = 1:20



SEE PAGE 1 FOR
ALL BLDGS

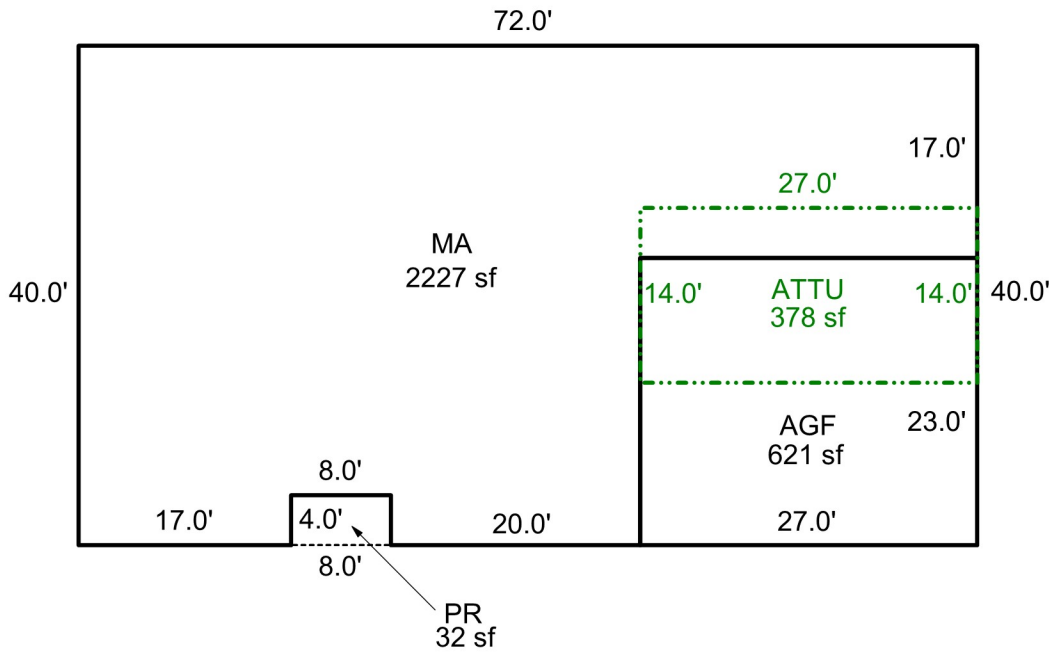

Sketch by Apex Sketch

AREA CALCULATIONS SUMMARY

Code	Description	Factor	Net Size	Perimeter	Net Totals
GLA1	MA	1.0	2227.0	232.0	2227.0
GLA2	ATTU	1.0	378.0	82.0	378.0
GAR	AGF	1.0	621.0	100.0	621.0
P/P	PR	1.0	32.0	24.0	32.0

COMMENT TABLE 1

Apex by RW 04/16/08
 UPDATED BY CJURAN 04/18/2022 555-22-000087
 UPDATED BY CJURAN 03/22/2023

COMMENT TABLE 2

MDL 12/17/2023

COMMENT TABLE 3

TAGS L2

Net LIVABLE cnt 2 (rounded) 2,605

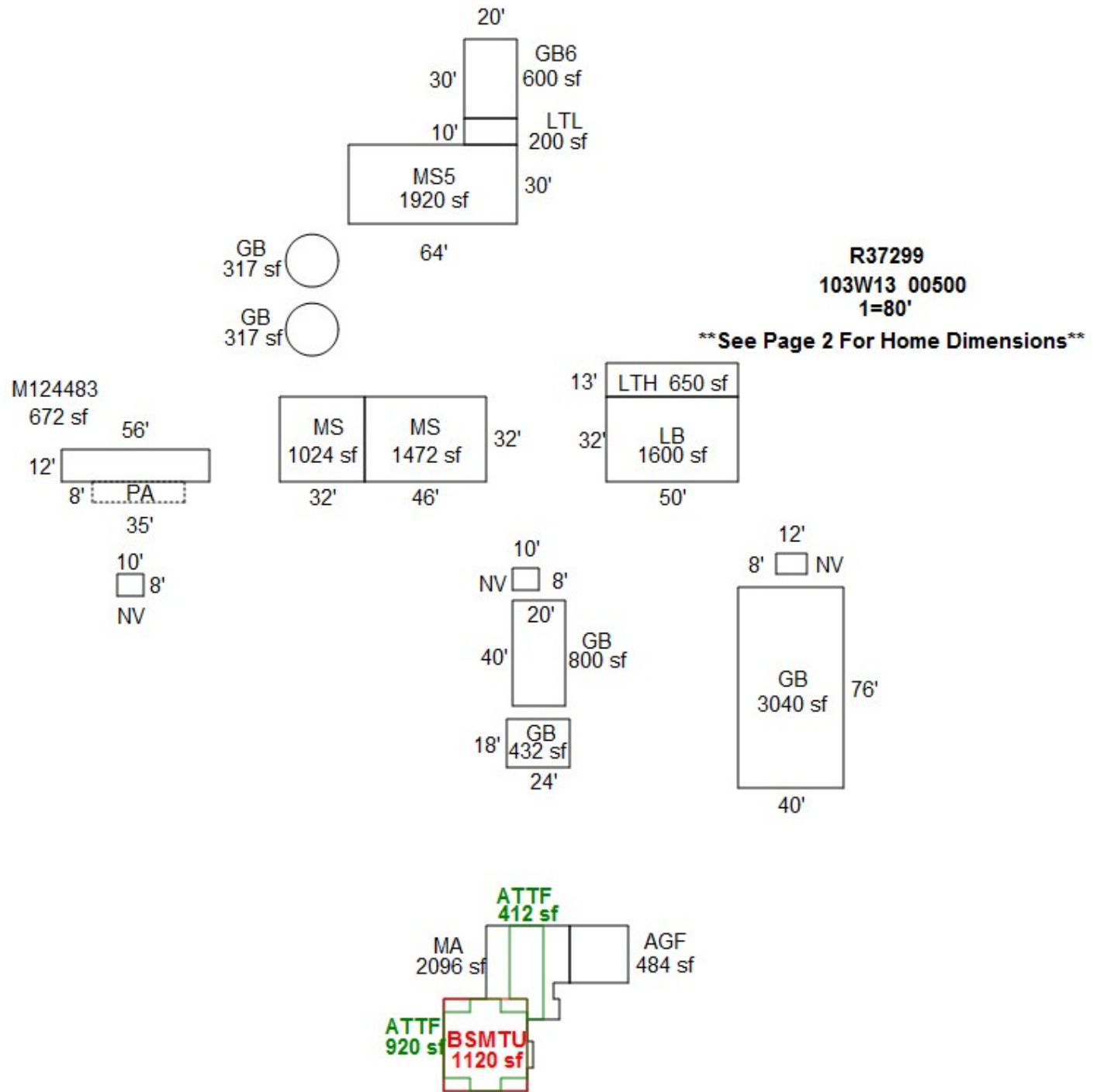

SKETCH/AREA TABLE ADDENDUM

SUBJECT INFO

File No.: 537299 Parcel No.: 103W13 00500
 Property Address: 3080 JEFFERSON SCIO DRIVE SE
 City: JEFFERSON County: State: OR ZipCode: 97352
 Owner:
 Client: Client Address:
 Appraiser Name: Inspection Date:

SKETCH

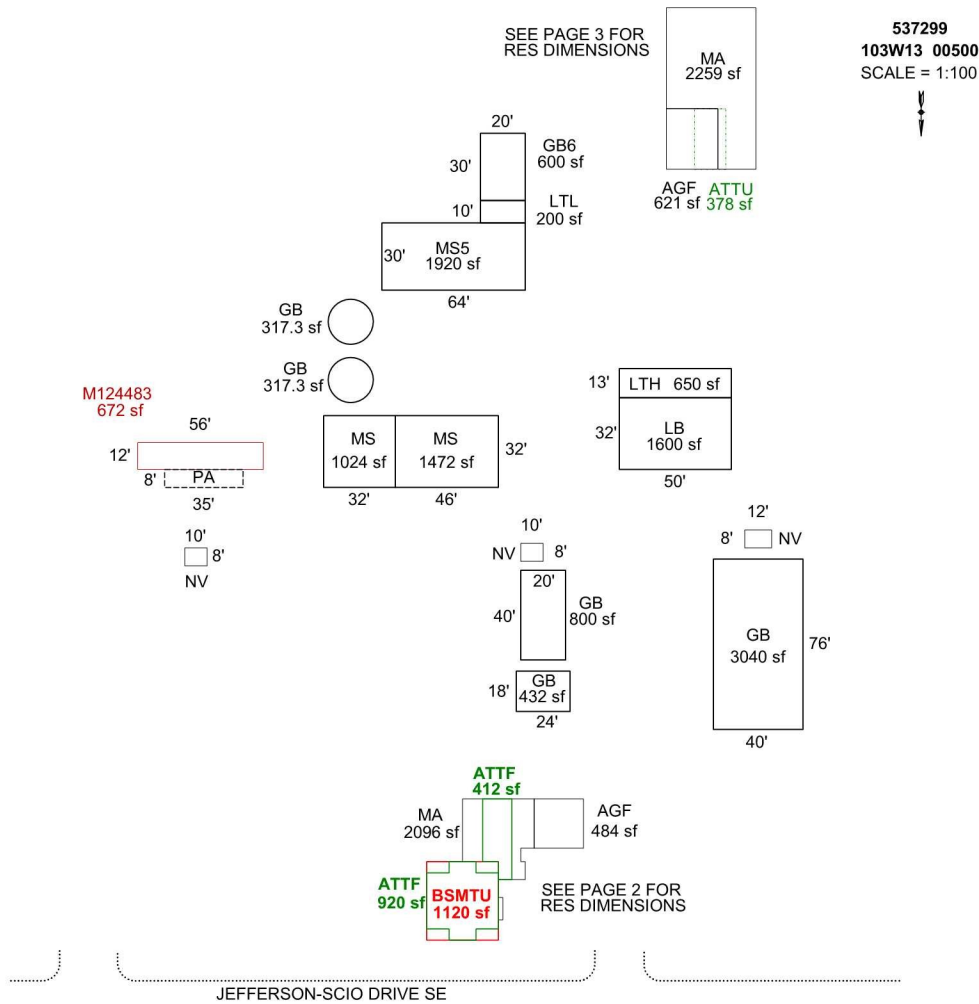

Sketch by Apex Sketch

AREA CALCULATIONS SUMMARY

Code	Description	Factor	Net Size	Perimeter	Net Totals	
GBA1	GB	1.0	317.3	63.1		
	LTH	1.0	650.0	126.0		
	GB6	1.0	600.0	100.0		
	LTL	1.0	200.0	60.0		
	GB	1.0	3040.0	232.0		
	GB	1.0	432.0	84.0		
	GB	1.0	800.0	120.0		
	MS5	1.0	1920.0	188.0		
	LB	1.0	1600.0	164.0		
	MS	1.0	1472.0	156.0		
	MS	1.0	1024.0	128.0		
	GB	1.0	317.3	63.1	12372.6	
	GLA1	MA	1.0	2096.0	230.0	
		ATTF	1.0	920.0	134.0	
GLA2	MA	1.0	2259.0	224.0	5275.0	
	ATTF	1.0	412.0	98.0		
	6 addl items					
	Net LIVABLE	cnt	5 (rounded)		6,065	
	Net BUILDING	cnt	12 (rounded)		12,373	

COMMENT TABLE 1

Apex by RW 04/16/08
 UPDATED BY CJURAN 04/18/2022 555-22-000087

COMMENT TABLE 2

COMMENT TABLE 3

SKETCH/AREA TABLE ADDENDUM

SUBJECT INFO

File No.: 537299 Parcel No.: 103W13 00500
 Property Address: 3080 JEFFERSON SCIO DRIVE SE
 City: JEFFERSON County: State: OR ZipCode: 97352
 Owner:
 Client: Client Address:
 Appraiser Name: Inspection Date:

SKETCH

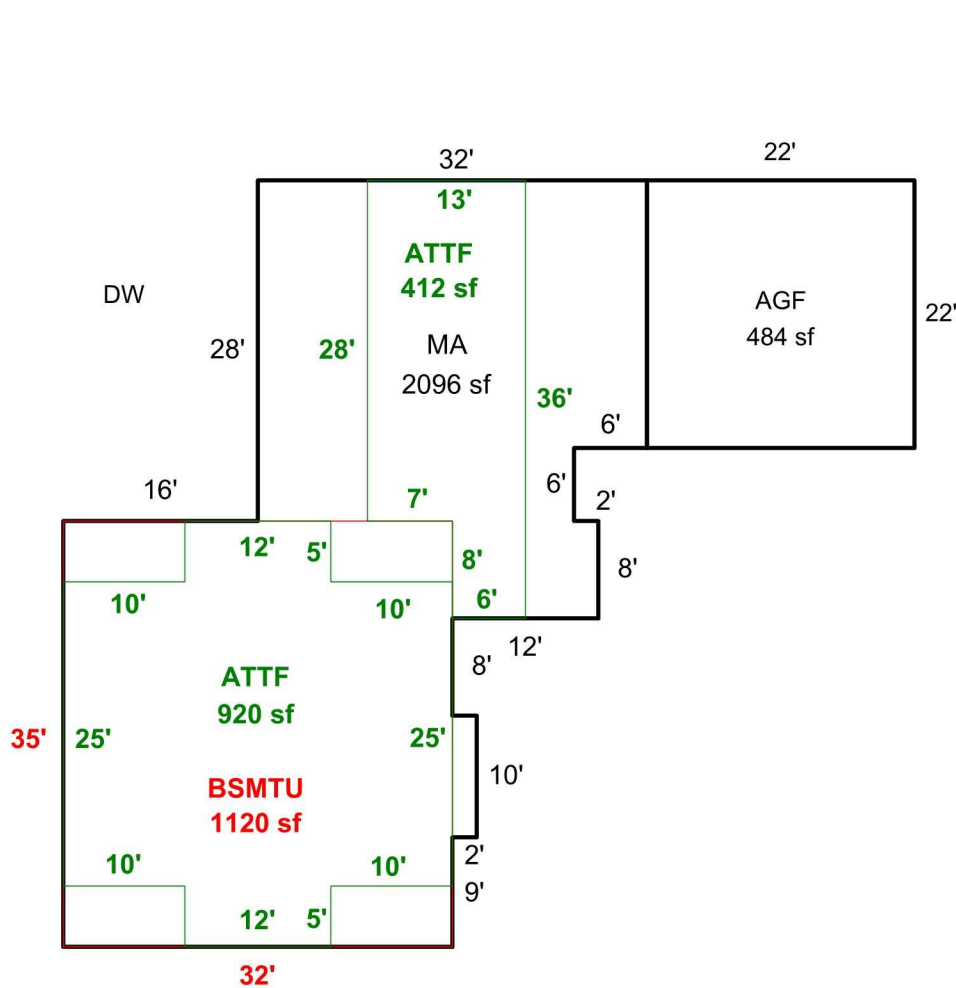

Sketch by Apex Sketch

AREA CALCULATIONS SUMMARY

Code	Description	Factor	Net Size	Perimeter	Net Totals
GLA1	MA	1.0	2096.0	230.0	
	ATTF	1.0	920.0	134.0	3016.0
GLA2	ATTF	1.0	412.0	98.0	412.0
BSMT	BSMTU	1.0	1120.0	134.0	1120.0
GAR	AGF	1.0	484.0	88.0	484.0

COMMENT TABLE 1

Apex by RW 04/16/08
 UPDATED BY CJURAN 04/18/2022 555-22-000087

COMMENT TABLE 2

COMMENT TABLE 3

Net LIVABLE cnt 3 (rounded) 3,428

SKETCH/AREA TABLE ADDENDUM

SUBJECT INFO

File No.: 537299 Parcel No.: 103W13 00500
 Property Address: 3080 JEFFERSON SCIO DRIVE SE
 City: JEFFERSON County: State: OR ZipCode: 97352
 Owner:
 Client: Client Address:
 Appraiser Name: Inspection Date:

SKETCH

537299
103W13 00500
 SCALE = 1:20



SEE PAGE 1 FOR
 ALL BLDGS

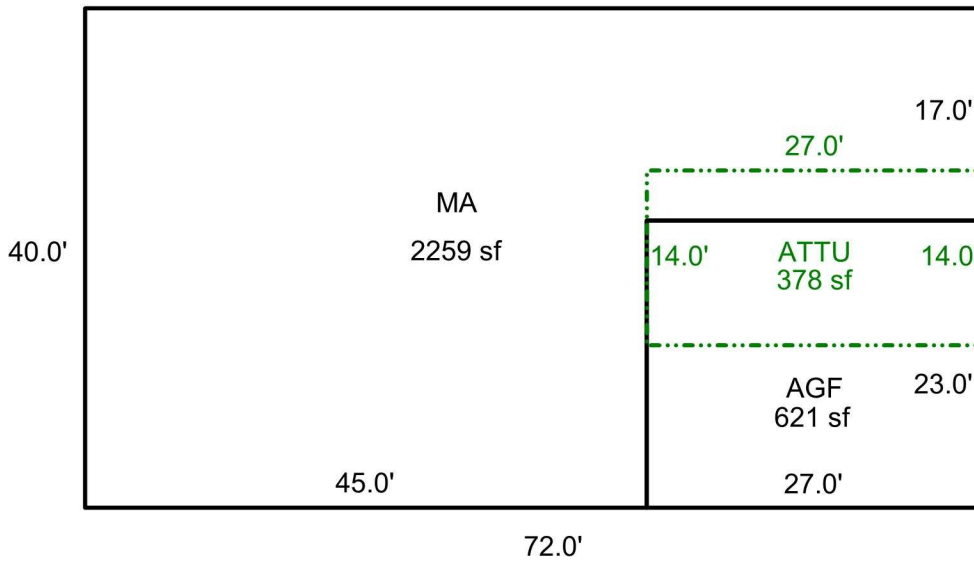

Sketch by Apex Sketch

AREA CALCULATIONS SUMMARY

Code	Description	Factor	Net Size	Perimeter	Net Totals
GLA1	MA	1.0	2259.0	224.0	2259.0
GLA2	ATTU	1.0	378.0	82.0	378.0
GAR	AGF	1.0	621.0	100.0	621.0

COMMENT TABLE 1

Apex by RW 04/16/08
 UPDATED BY CJURAN 04/18/2022 555-22-000087

COMMENT TABLE 2

COMMENT TABLE 3

Net LIVABLE cnt 2 (rounded) 2,637

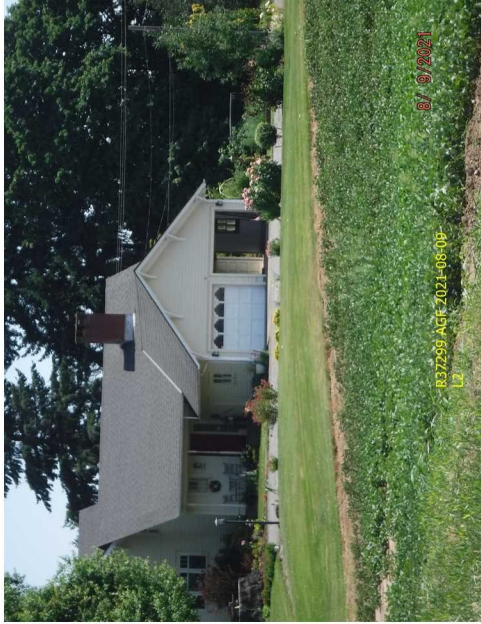



Statesman













82483

HOLIDAY RAMBLER