

SKETCH/AREA TABLE ADDENDUM

SUBJECT INFO

File No.: R105365 Parcel No.: 091W03BB02600
 Property Address: 811 SW 9TH ST
 City: SUBLIMITY County: State: OR ZipCode: 97385
 Owner:
 Client: Client Address:
 Appraiser Name: Inspection Date:

SKETCH

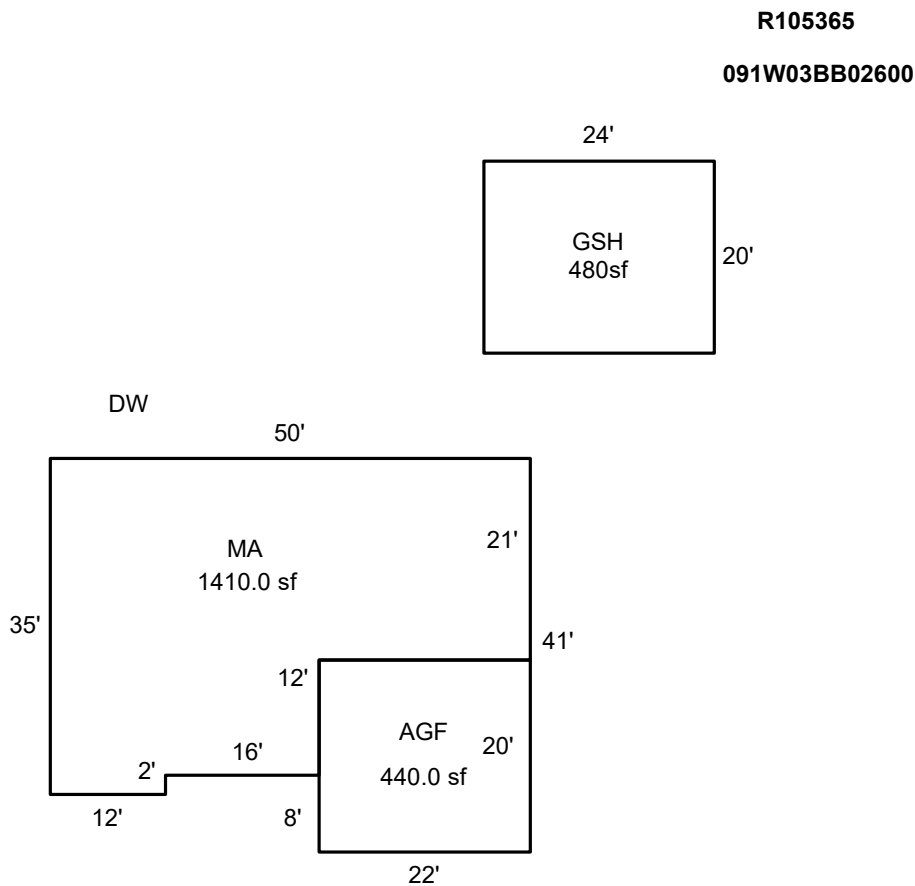

Sketch by Apex Sketch

AREA CALCULATIONS SUMMARY						COMMENT TABLE 1	
Code	Description	Factor	Net Size	Perimeter	Net Totals		
GLA1	MA	1.0	1410.0	170.0	1410.0	DRAWN BY SH 2-23-09 UPDATED BY CBAILEY 2/12/21	
GAR	AGF	1.0	440.0	84.0	440.0		
OTH	GSH	1.0	480.0	88.0	480.0		
						COMMENT TABLE 2	COMMENT TABLE 3
Net LIVABLE		cnt	1 (rounded)	1,410			