

SKETCH/AREA TABLE ADDENDUM

SUBJECT INFO

File No.: R104703 Parcel No.: 091W09AD00400
 Property Address: 1267 WILSHIRE DR
 City: STAYTON County: State: OR ZipCode: 97383
 Owner:
 Client: Client Address:
 Appraiser Name: Inspection Date:

SKETCH

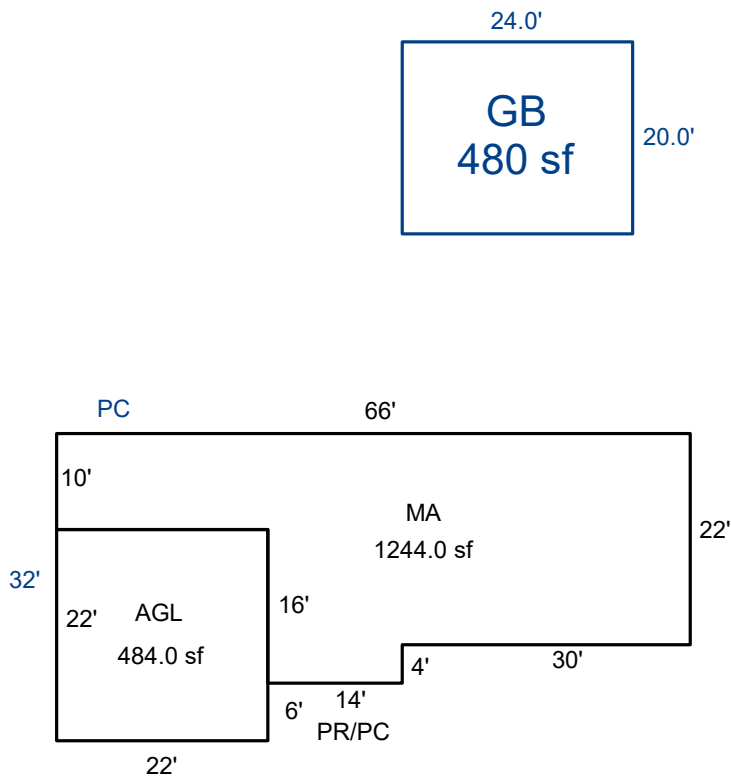

R104703
091W09AD00400

Sketch by Apex Sketch

AREA CALCULATIONS SUMMARY

Code	Description	Factor	Net Size	Perimeter	Net Totals
GBA1	GB	1.0	480.0	88.0	480.0
GLA1	MA	1.0	1244.0	184.0	1244.0
GAR	AGL	1.0	484.0	88.0	484.0

COMMENT TABLE 1

DRAWN BY SH 3-11-09
 UPDATED BY CBAILEY 12/29/20

COMMENT TABLE 2

COMMENT TABLE 3

Net LIVABLE	cnt	1	(rounded)		1,244
Net BUILDING	cnt	1	(rounded)		480